



AgileLight-100A

Closed Loop Single Axis Fibre Optic Gyroscope

Technical Manual



Introduction

As an interference type digital closed-loop single-axis fiber optic gyroscope, AgileLight-100A has the advantages of low cost, large working bandwidth, high resolution, small zero drift, high linearity, short starting time, impact resistance and vibration resistance, it is an alternative to traditional mechanical gyros.

AgileLight-100A fiber optic gyroscope adopts IntelliProcess technology, which not only greatly eliminates the influence of temperature change on gyroscope performance, but also improves the key indicators of fiber optic gyroscope such as zero bias stability, angular random walk, scale factor linearity and stability. With low bias stability and angular random walk and strong vibration resistance, it is suitable for a variety of industrial applications. The high performance, rugged adaptability, compact construction and competitive price of the AgileLight-100A make it the recommended choice for motion sensing, platform stabilization, navigation and precision targeting.

Features

- All fiber optic technology: Long life, small size, high stability, anti-interference angle sensor.
- IntelliProcess Technology: Built-in high-performance digital signal processing chip for full digital operation and adaptive filtering technology makes the gyro's zero drift and angular velocity random walk 50%-75% lower than similar products.
- Integrated fiber polarization technology: reduces insertion loss, increases extinction ratio, and provides better resistance to temperature, mechanical shock and vibration for optical paths
- Compact and highly stable package: adapt to a variety of harsh environments. Widely applicable to all kinds of civil and military occasions
- QuickLaunch technology: Realize instant start-up, No external calibration required
- Optimal operating wavelength: sensitivity is increased by nearly 50% with the same structure, size and cost.
- Noise isolation and compression techniques: significantly reduce the angular velocity random walk
- SelfTrack technology: increase the dynamic range of the gyroscope

Applications

- Motion attitude control
- Servo tracking
- Damping of high speed train swing
- Antenna/Radar/optical platform stabilization
- Monitoring structural deformation
- Inertial north seeking
- Automatic goods trolley
- Robot balance
- Guidance and navigation
- Locking of the aiming system
- Oil drilling
- Miniature IMU, INS

Details

Performance Objective

	Axis	Single axis
Technical Parameter	Measuring range (°/s)	-450~450
	Bias stability (°/h) , 1 σ	≤ 1
	Bias repeatability (°/h) , 1 σ	≤ 1
	Random walk coefficient (°/ $\sqrt{\text{hr}}$)	≤ 0.1
	Scale factor nonlinearity (ppm)	≤ 300
	Scale factor asymmetry (ppm)	≤ 300
	Scale factor repeatability (ppm) , 1 σ	≤ 300
	Physical Characteristics	Frequency bandwidth (Hz)
Start-up time (s)		≤ 1
Power Supply (V)		-5~+5
Power consumption (W)		≤ 5
Size(mm)		$\Phi 50 \times H38$
Weight (g)		≤ 160
Output mode		RS 422
Working temperature (°C)		-40~+65
Storage temperature (°C)		-45~+85
Connector		J30J-15TJL

Mechanical Characteristic

● Gyroscope polar >

The polarity of X, Y, and Z gyros is defined by the right-hand helix rule, and the three axes are orthogonal. The thumb represents the direction of the sensitive axis, and the other fingers represent the direction of the angular velocity.

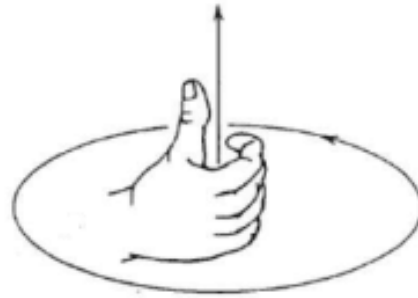
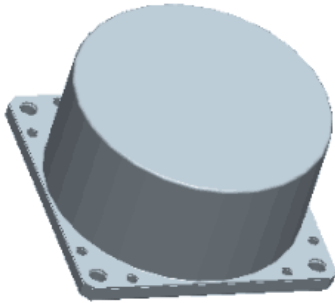

● Working power supply >

$\pm 5V$ for power supply, power accuracy is $\pm 5\%$, Power ripple is $\leq 20mV$. $+5V$ power supply is 15W, as well as the $-5V$ is 15W. Steady state power consumption in normal temperature is $\leq 12W$, while in full temperature the steady state power consumption is $\leq 15W$.

● Definition of output interfaces >

The gyroscope use J30J-15TJL connector, the length is $160mm \pm 20mm$ long, the definitions of the nodes are seen in Table 1.

Node number	Definition	Remark
1	+5V	+5V power input
2	-5V	-5V power input
3	$\pm 5V$ GND	GND
4	T1+	X gyroscope output signal +
5	T1-	X gyroscope output signal -
6	T2+	Y gyroscope output signal +
7	T2-	Y gyroscope output signal -
8	T3+	Z gyroscope output signal +
9	T3-	Z gyroscope output signal -

Table 1: definition of J30J-15TJL

 Package size

Product Size: $\Phi 50 \times H38$ (mm)

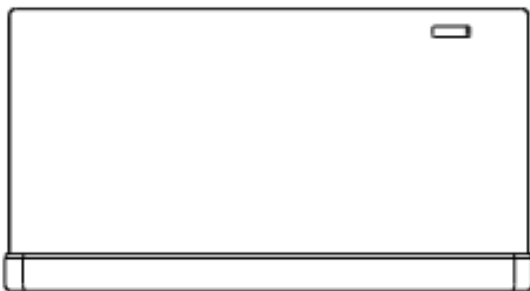
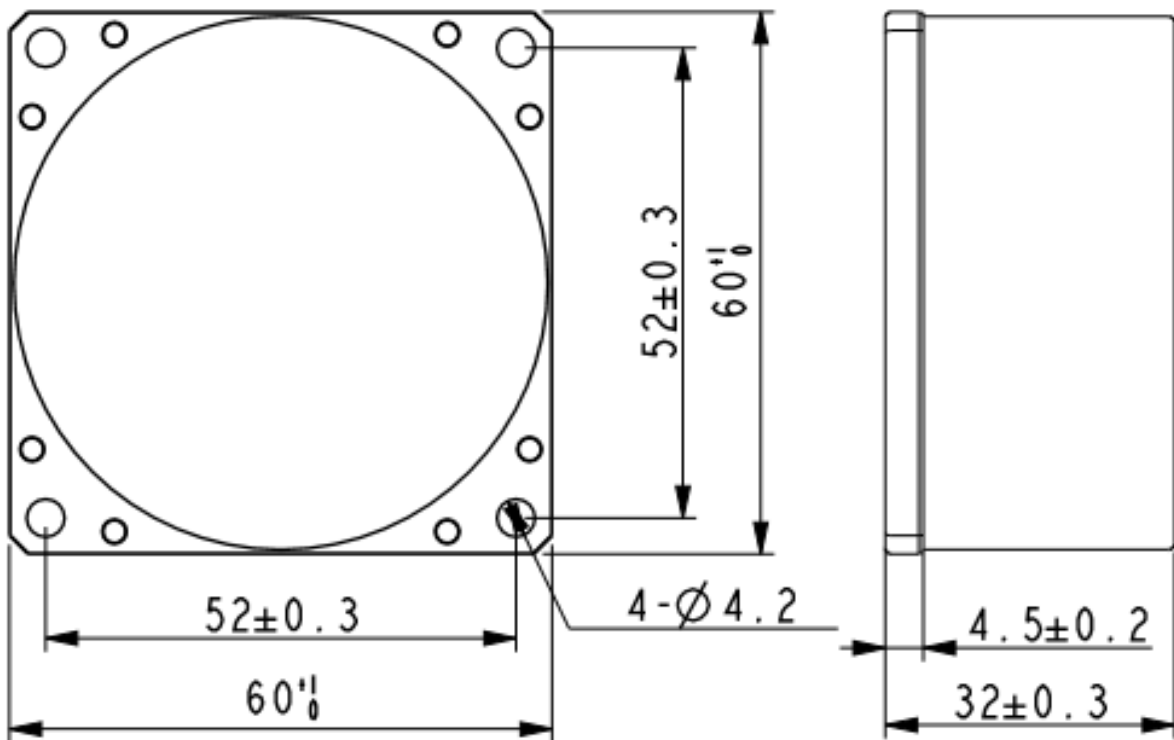

Protocol

RS-422 digital serial port, use electrical interface standard of asynchronous serial standard duplex RS-422.

- Baud rate: 115.200kbps ;
- Communication frame format , each frame contains 11 bits, the order is:

1 bit for stat bit

8 bits for data bit(send low bit first before the high bit)

1 bit for parity check

1 bit for stop bit

- Communication rule

The gyroscope uses broadcast communication, the data update for 2ms, the data frame formats are shown in Table 2.

Bits	Definition	Bit 7	6	5	4	3	2	1	Bit 0
1	Header	1	0	0	0	0	0	0	0
2	High 8 bits	0	D27	D26	D25	D24	D23	D22	D21
3	Middle 8 bits	0	D20	D19	D18	D17	D16	D15	D14
4	Middle 8 bits	0	D13	D12	D11	D10	D9	D8	D7
5	Low 8 bits	0	D6	D5	D4	D3	D2	D1	D0
6	Frame check	2 to 5 bytes bit by bit XOR							
7	Temp	0	T13	T12	T11	T10	T9	T8	T7
8	Temp	0	T6	T5	T4	T3	T2	T1	T0

Table 2: Frame format of output data

Circumstance

- Working temperature: -40°C ~ +60°C;
- Random vibration:
 - 20 ~ 80Hz : 3dB/oct;
 - 80 ~ 350Hz : 0.04g²/Hz;
 - 350 ~ 2000Hz : -3dB/oct;
- Vibration time: 3min;
- Vibration direction: two directions of the three orthogonal axes.
- Impact
 - Impact waveform: half-sin wave;
 - Peak acceleration: 30g; Pulse duration: 6—8ms;
 - Impact diretion: two directions of the three orthogonal axes;
 - Impact times: two times in each direction.



AgileLight-100A

Closed Loop Single Axis Fibre Optic Gyroscope

Executive standard

- Enterprise Quality System Standard: ISO9001:2008 Standard(Certificate No.10114Q16846ROS)
- CE certification (certificate number: 3854210814)
- RoHS (certificate number: G190930099)

AgileLight-100A

Closed Loop Single-Axis
Fibre Optic Gyroscope

Wuxi Bewis Sensing Technology LLC

Address: Building 30, No. 58 Xiuxi Road, Binhu District, Wuxi City, Jiangsu Province, China

Tel/Whatsapp: +86 189 2129 2620

Email: support@bwsensing.com

Website: www.bwsensing.com