



BW-AH327 Serials

High cost performance Modbus AHRS

Technical Manual



Introduction

BW-AH327 Attitude and Heading Reference System (AHRS) is a high performance, low cost inertial measurement device that measures the attitude parameters (roll and pitch), angular velocity, acceleration information and heading angle of the dynamic carrier. The attitude and angular velocity deviations are estimated by a 6-state Kalman filter with appropriate gain, which is suitable for dynamic measurement of navigation and positioning. The BW-AH327 uses high-quality and reliable MEMS accelerometers, gyroscopes and magnetometers, and guarantees measurement accuracy through algorithms. Meanwhile, the seal design and strict process ensure that the dynamic parameters of the carrier such as the angular velocity, acceleration and attitude can be accurately measured under harsh conditions. Through various compensations such as nonlinear compensation, quadrature compensation, temperature compensation and drift compensation, the error source of BW-AH327 can be greatly eliminated, and the product accuracy level can be improved. The BW-AH327 is equipped with digital interface that can be easily integrated into the user's system.

Feature

- Nonlinear compensation, quadrature compensation
- Dynamic static measurement
- Special offset tracking algorithm eliminates drift
- Gyro drift compensation
- Heading accuracy 0.8°
- RS232/485/TTL/Modbus interface output is optional
- temperature range: -40°C~+85°C, temperature compensation technical
- High performance Kalman filter algorithm
- Product size: L60 x W59 x H29 (mm)

Application

- Satellite tracking
- High voltage tower monitoring
- Aerial work vehicle
- ROV underwater robot navigation
- Drilling equipment measurement and control
- Ocean Tester
- Robot control
- Unmanned aerial vehicle

Introduction

Electrical Specifications

Voltage	9-35V DC
Working current	30mA (40mA max)
Operating temperature	-40~85°C
Storage temperature	-55~100°C

Performance Specifications

Attitude parameters	Pitch Accuracy	0.5° (RMS, dynamic) 0.1° (RMS, Static)
	Roll accuracy	0.5° (RMS, dynamic) 0.1° (RMS, Static)
	Resolution	0.01°
	Slant Range	Pitch ± 90°, Roll ± 180°
Heading parameters	Heading Accuracy	0.8° (Pitch<40°)
		1° (Pitch<60°)
		1.2° (Pitch<80°)
	Resolution	0.01°
Physical characteristics	Size	L60 x W59 x H29 (mm)
	Weight	150g
	Output form	RS232/RS485/TTL/Modbus
Interface characteristics	Start Delay	<3s
	Maximum Output Rate	50Hz
	Serial Communication Rate	2400-115200 Baud rate
	Digital Output Format	Binary high performance protocol
Environment	Vibration Resistance	2000g

Resolution: The smallest change in the value that the sensor can detect and resolve within the measurement range.

Accuracy: The root mean square error of the actual angle and the measured angle of the sensor multiple times (≥16 times).

 Mechanical Characteristic

Connector	Metal joint (Line length 1.5m)
Protection level	IP67
Shell material	Magnesium alloy oxidation
Installation	Four M4 screws

 Package size

Size: L60*W59*H29 (mm)

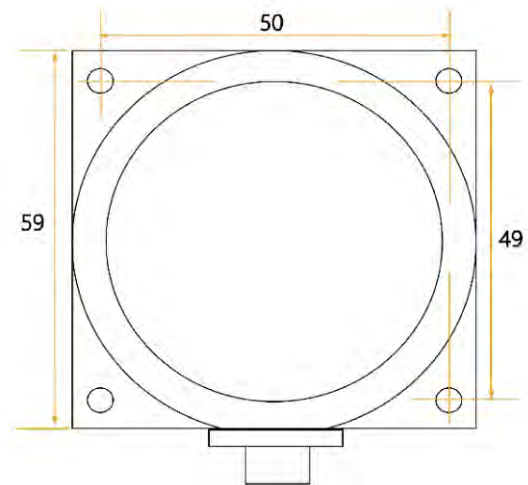
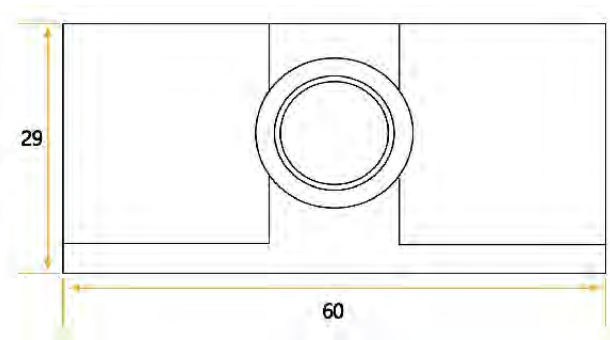

 Bare plate product size

Size: L44*W35*H11 (mm)

Note: ±1mm error for length and width dimensions, please refer to actual size.

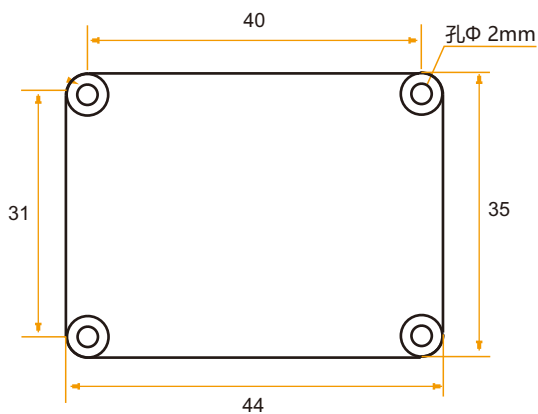

Product installation

The correct installation method can avoid measurement errors, and the following points should be taken when installing the sensor:

First of all, to ensure that the sensor mounting surface is completely close to the measured surface, the measured surface should be as horizontal as possible, and there should be no angle shown in Figure A and Figure C. The correct installation method is shown in Figure B and Figure D.

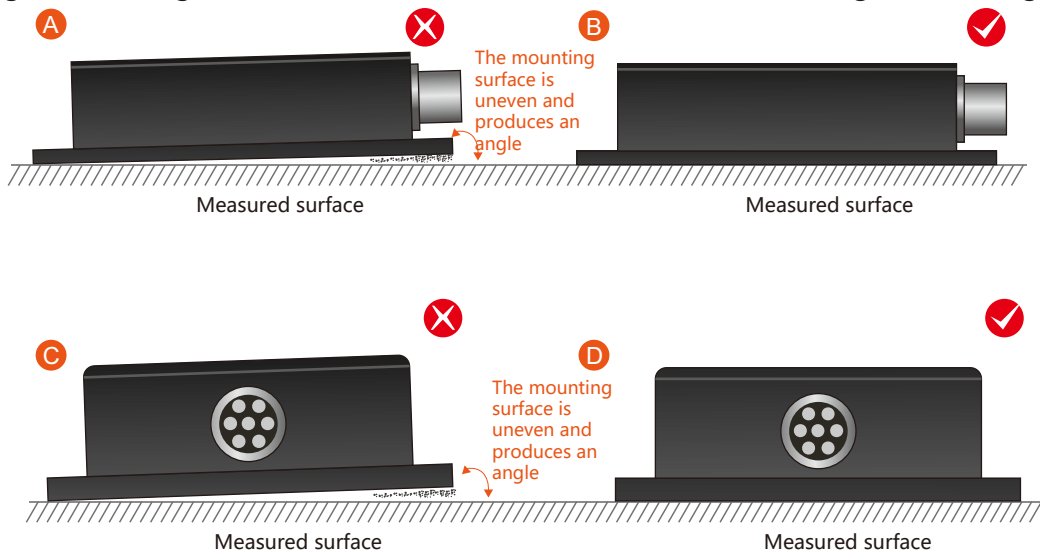

Secondly, the bottom edge of the sensor and the axis of the object to be measured cannot be generated at an angle as shown in Figure E. The bottom edge of the sensor should be kept parallel or orthogonal to the axis of rotation of the object to be measured. This product can be installed horizontally or vertically (vertical installation requires customization), and the correct installation method is shown in Figure F.

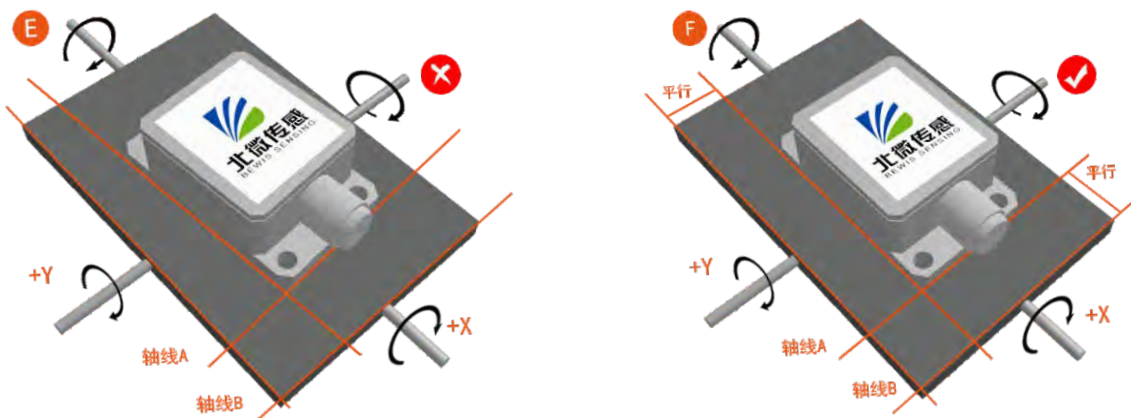

Finally, the mounting surface of the sensor and the surface to be measured must be fixed, the contact is flat, and the rotation is stable. The measurement error caused by acceleration and vibration should be avoided.

Calibration method

Azimuth calibration steps:

Method 1 - Plane calibration:

1. Connect the product to the system and place the product in a horizontal state;
2. Open the serial port debugging tool and send 01 06 00 14 00 00 **C9 CE** ;
3. Rotate the product in the horizontal plane (with the pitch and roll angles within $\pm 5^\circ$) around the z-axis (the z-axis is vertical), rotate 2-3 turns, and rotate as slowly as possible. Rotating at a uniform speed, the time of one rotation is controlled between 10 seconds and 15 seconds;
4. Rotate the compass around the x-axis or y-axis. The rotation process can be performed at a slow speed and near-uniform rotation. It rotates 2-3 turns around each axis, and the rotation time is about 15 seconds.
5. Complete the calibration and send 01 06 00 15 00 00 **98 0E** Save the calibration.

Method 2 - Multi-faceted calibration:

1. Fix the product in the use environment, and try not to carry magnetic items such as keys and mobile phones during calibration;
2. Place the compass in a horizontal state (within ± 5 degrees);
3. Send the following calibration command in hexadecimal format: 01 06 00 11 00 00 **D9 CF**;
4. The product is placed horizontally, face up (pitch and roll are within 0 ± 5 degrees), rotate about one rotation at a constant speed, and rotate for one week for more than 10 seconds;
5. The product is placed in a horizontal state with the mounting surface facing up (with a pitch of 0 ± 5 degrees and a horizontal roll of 180 ± 5 degrees).

One week, it takes about 10 seconds to rotate one week;

6. The product is placed in a vertical position with the smooth side of the casing facing down (with a pitch of 0 ± 5 degrees and a roll of 90 ± 5 degrees).

Rotate at a uniform speed for one week, and it takes about 10 seconds to rotate one week;

7. The product is placed in a vertical position with the other smooth side of the housing facing down (with a pitch of 0 ± 5 degrees and a roll of -90 ± 5 degrees)

Inside), myopia rotates at a constant speed for one week, and it takes about 10 seconds to rotate one week;

Where 4.5.6.7 steps can be exchanged;

8. After the four faces have been rotated, send the hexadecimal command 01 06 00 12 00 00 **29 CF** to save the calibration;

9. Calibration is complete.

Clear calibration command: 01 06 00 13 00 00 **78 0F**

Note: The green font is the CRC check digit.

Electrical connections

Wiring definition

	RED	BLUE	BLACK	GREEN	YELLOW
Cable color	1	2	3	4	5
function	VCC DC 9-35V	NC	GND	RXD (B, D-)	TXD (A, D+)

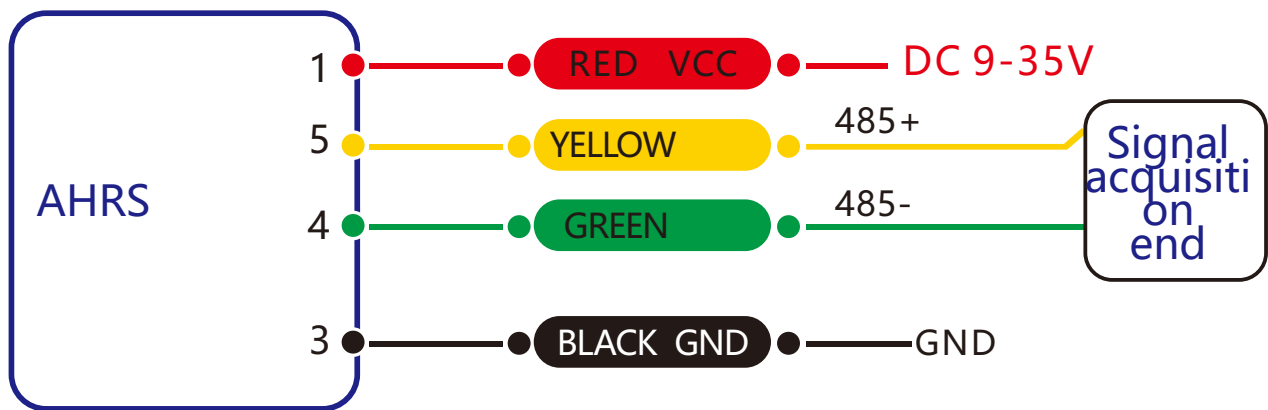

RS485wiring diagram

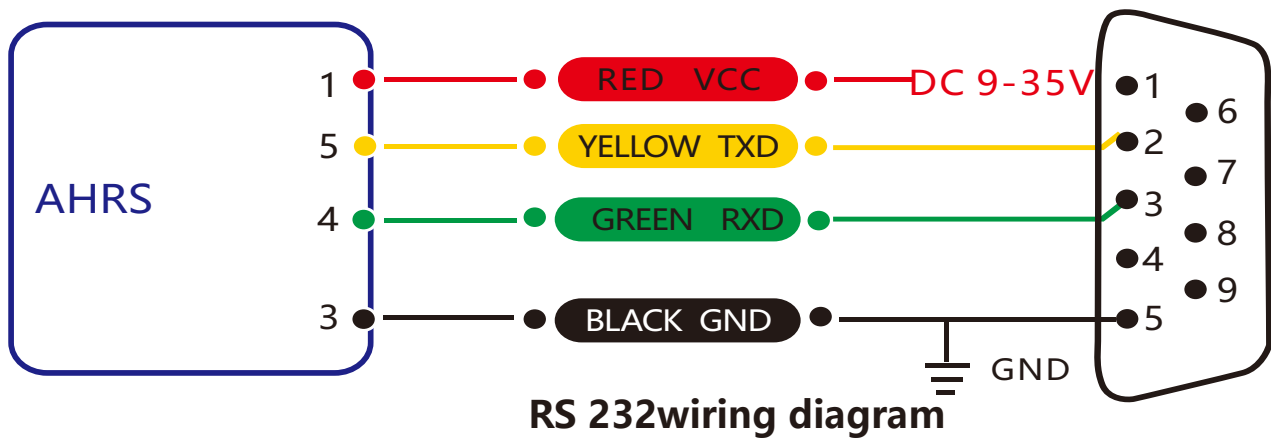

RS 232wiring diagram

Protocol

1 Data frame format: (8-bit data bit, 1 stop bit, no parity, default rate 9600)

address code (1byte)	function code (1byte)	Read the first address of the register (2byte)	read number of registers (2byte)	CRC check (2byte)
0x01	03 (read) 06 (write)	XX XX	XX XX	XX XX

Data format: hexadecimal

Address code: The default is 01 (Note: the address cannot exceed FF)

Function code: 03 means read register, 06 means pre-made register

Address of the register: the start address of the register to be operated

Number of registers: The number of registers that need to be operated.

CRC check: Calculated by the host. (Recommended by CRC calculation software)

Note: If you use the serial port assistant without MODBUS function to communicate with the product, you need to add the CRC check at the end of the command. If you use the serial port assistant with MODBUS protocol to communicate with the product, do not add CRC check.

Register storage information:

Register 1: Pitch angle

Register 2: Roll angle

Register 3: Azimuth angle

Register 4: Product Address

Register 5: Zero type

2 Command format:

2.1 Read PITCH pitch angle Send command: 01 03 00 01 00 01 D5 CA

address code (1byte)	function code (1byte)	Read the first address of the register (2byte)	read number of registers (2byte)	CRC check (2byte)
0x01	0x03	00 01	00 01	xx xx

Answer command:

address code (1byte)	function code (1byte)	Data field bytes (1byte)	Data field (2byte)	CRC check (2byte)
0x01	0x03	0x02	XX XX	ZZ ZZ

Among them, XX XX represents the pitch angle, and the angle value is hexadecimal (the number read by PLC or configuration software is directly decimal)

The angle is calculated as follows:

Actual angle = (converted to decimal data field - 20,000) / 100.

For example, the angle value return value is 3D52, the conversion to decimal is 15698, the real data is (15698-20000)/100=-43.02 degrees, and the other axes are the same.

2.2 Read ROLL roll angle Send command: 01 03 00 02 00 01 25 CA

address code (1byte)	function code (1byte)	Read the first address of of the register (2byte)	read number of registers (2byte)	CRC check (2byte)
0x01	0x03	0x02	00 01	XX XX

Answer command

address code (1byte)	function code (1byte)	Data field bytes (1byte)	Data field (2byte)	CRC check (2byte)
0x01	0x03	0x02	XX XX	ZZ ZZ

2.3 Read Heading Azimuth Angle Send Command: 01 03 00 03 00 01 74 0A

address code (1byte)	function code (1byte)	Read the first address of the register (2byte)	read number of registers (2byte)	CRC check (2byte)
0x01	0x03	00 03	00 01	XX XX

Answer command

address code (1byte)	function code (1byte)	Data field bytes (1byte)	Data field (2byte)	CRC check (2byte)
0x01	0x03	0x02	XX XX	ZZ ZZ

2.4 Read PITCH, ROLL, and HEADING axis angles Send Command: 01 03 00 01 00 03 54 0B

address code (1byte)	function code (1byte)	Read the first address of the register (2byte)	read number of registers (2byte)	CRC check (2byte)
0x01	0x03	00 01	00 03	XX XX

Answer command

address code (1byte)	function code (1byte)	Data field bytes (1byte)	Data field (3byte)	CRC check (2byte)
0x01	0x03	0x06	XX XX YY YY ZZ ZZ	ZZ ZZ

XX XX represents the PITCH angle, YY YY represents the ROLL angle, and ZZ ZZ represents the HEADING angle.

2.5 Set absolute/relative zero Send Command: 01 06 00 0A 00 00 A9 C8 / 01 06 00 0A 00 01 68 08

address code (1byte)	function code (1byte)	function code (2byte)	Zero type (2byte)	CRC check (2byte)
0x01	0x06	00 0A	0000 (absolute) 00 01 (relatively)	XX XX

Answer command

address code (1byte)	function code (1byte)	function code (2byte)	Zero type (2byte)	CRC check (2byte)
0x01	0x06	00 0A	0000 (absolute) 00 01 (relatively)	XX XX

Note: If set to absolute zero, the measurement angle is based on the zero point of the product.
 If set to a relative zero point, the measurement angle is zero reference to the current installation position.
 The zero point is the zero point of the inclination angle. When installing, try to install it at the zero point attachment, and the inclination angle changes more, which will cause the azimuth angle to change.

2.6 Query absolute/relative zero Send Command: 01 03 00 05 00 01 94 0B

address code (1byte)	function code (1byte)	Read the first address of the register (2byte)	read number of registers (2byte)	CRC check (2byte)
0x01	0x03	00 05	00 01	XX XX

Answer command

address code (1byte)	function code (1byte)	Data field bytes (1byte)	Data field (2byte)	CRC check (2byte)
0x01	0x03	0x02	00 00 (absolute) 00 01 (relatively)	ZZ ZZ

2.7 Set the communication rate Send Command: 01 06 00 0B 00 02 79 C9

address code (1byte)	function code (1byte)	function code (2byte)	Baud rate type (2byte)	CRC check (2byte)
0x01	0x06	00 0B	XX XX	XX XX

Answer command

address code (1byte)	function code (1byte)	function code (2byte)	Data field (2byte)	CRC check (2byte)
0x01	0x06	00 0B	XX XX	ZZ ZZ

Note: If XX XX in the baud rate type is 0000, the baud rate is changed to 2400;

0001 indicates that the baud rate is modified to 4800;

0002 indicates that the baud rate is modified to 9600 (default value);

0003 indicates that the baud rate is modified to 19200;

0004 indicates that the baud rate is changed to 115200.;

After sending this command, the baud rate changes immediately and the return value is generally confusing.

2.8 Set product address Send Command: 01 06 00 0D 00 02 99 CB

address code (1byte)	function code (1byte)	function code (2byte)	Modified address (2byte)	CRC check (2byte)
0x01	0x06	00 0D	HH LL	XX XX

Answer command

address code (1byte)	function code (1byte)	function code (2byte)	Modified address (2byte)	CRC check (2byte)
0xLL	0x06	00 0D	HH LL	ZZ ZZ

Note: HH LL indicates the product address to be changed, HH indicates the upper address of the address, and LL indicates the status of the address. The address range is 00 00-00 FF. In the example, the address of the product is changed to 00 02 .

2.9 Query product address Send Command: 77 04 00 2F 33

Identifier (1byte)	Byte length (1byte)	Product Custom Protocol Address (1byte)	function code (1byte)	MODBUS address (1byte)	Checksum (1byte)
0x77	0x04	0x00	0x2F	e)	0x33

Answer command

Identifier (1byte)	Byte length (1byte)	Product Custom Protocol Address (1byte)	function code (1byte)	MODBUS address (1byte)	Checksum (1byte)
0x77	0x05	0x00	0x2F	e)XX	XX

Note: Since the MODBUS protocol stipulates that the product must know the module address to communicate, when the MODBUS protocol communicates, the address is known in advance, and the address cannot be queried. The query address of this product is a custom protocol used to query the address of the MODBUS protocol. For a custom protocol, see the product introduction for the custom protocol. And the command is valid within 10 seconds before power-on.

The XX in the MODBUS address is the product address of the protocol.

2.10 Save Settings Send Command: 01 06 00 0F 00 00 78 09

address code (1byte)	function code (1byte)	function code (2byte)	- (2byte)	CRC check (2byte)
0x01	0x06	00 0F	00 00	XX XX

Answer command

address code (1byte)	function code (1byte)	function code (2byte)	Zero type (2byte)	CRC check (2byte)
0x01	0x06	00 0F	00 00	XX XX

Note: All of the previous settings need to be changed and sent under uninterrupted power. Otherwise, there is no memory function.

Ordering Information

Product number	way of communication	Package condition
BW-AH327-232	RS232	IP67 package / metal connector
BW-AH327-485	RS485	IP67 package / metal connector
BW-AH327-TTL	TTL	IP67 package / metal connector

Executive standard

- Enterprise quality system standards: ISO9001: 2008 standard (certificate number: 10114Q16846ROS)
- CE certification (certificate number: 3854210814)
- ROHS (certificate number: SO81426003)
- GB/T 191 SJ 20873-2003 General specification for inclinometer and level
- GBT 18459-2001 sensor static performance index calculation method
- JJF 1059-1999 Measurement uncertainty evaluation and representation
- GBT 14412-2005 Mechanical vibration and shock Mechanical installation of accelerometer
- GJB 450A-2004 General requirements for equipment reliability
- Quality control of key parts and important parts of GJB 909A
- GJB 899 reliability identification and acceptance test
- GJB150-3A high temperature test
- GJB150-4A low temperature test
- GJB150-8A rain test
- GJB150-12A sand dust test
- GJB150-16A vibration test
- GJB150-18A impact test
- GJB150-23A tilt and rocking test
- GB/T 17626-3A RF electromagnetic field radiation immunity test
- GB/T 17626-5A surge (shock) impulse immunity test
- GB/T 17626-8A power frequency magnetic field immunity test
- GB/T 17626-11A Immunity of voltage dips, short interruptions and voltage changes

BW-AH327

High cost performance Modbus AHRS

Wuxi Bewis Sensing Technology LLC

Address: Building 30, No. 58 Xiuxi Road,

Binhu District,

Wuxi City

Hotline: 400-618-0510

Tel: +86 510 85737178-801

Email: sales@bwsensing.com

Website: www.bwsensing.com