

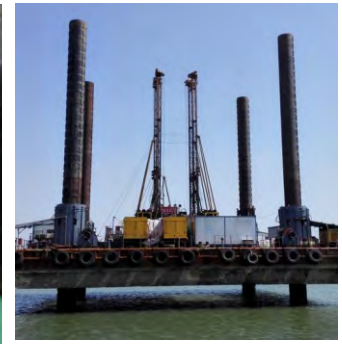

BW-VG50 Serials

**Low Cost Digital Dynamic
Inclination Sensor**

Technical Manual



@kif [| Zk`f e

The BW-VG50 Dynamic Inclination Sensor is a low-cost inclinometer that measures the attitude parameters (roll and pitch) of the motion carrier. The attitude deviation is estimated by a 6-state Kalman filter with appropriate gain and is suitable for tilt measurement in motion or vibration.

The BW-VG50 uses high-quality and reliable MEMS accelerometers and gyroscopes, and guarantees measurement accuracy through algorithms. At the same time, the seal design and strict process ensure that the product can accurately measure the roll angle and pitch angle of the carrier under harsh environment. Through various compensations such as nonlinear compensation, quadrature compensation, temperature compensation and drift compensation, the error caused by interference can be greatly eliminated, and the product precision level can be improved. The BW-VG50 has a digital interface that can be easily integrated into the user's system.

=\Xk i \j

- Nonlinear compensation, quadrature compensation
- Dynamic static measurement
- Special offset tracking algorithm eliminates the drift
- Gyro drift compensation
- RS232/RS485/TTL/CAN interface output for optional
- Operating temperature: -40°C~+85°C
- High performance Kalman filter algorithm
- Small size: L55 x W37 x H24(mm)

8ggcZXk`f ej

- Balance car
- Attitude measurement
- Platform stability
- Individual combat equipment
- ROV underwater robot navigation
- Ocean test
- Robot
- Unmanned Aerial Vehicle

Specifications

Electrical Specifications

Power supply	5V DC
Operating current	30mA (Max40mA)
Operating temperature	-40°C~85°C
Store temperature	-55°C~100°C

Performance Specifications

Attitude parameter	Dynamic accuracy	3°
	Static accuracy	0.3°
	Resolution	0.01°
	Tilt range	Pitch $\pm 90^\circ$, Roll $\pm 180^\circ$
Physical characteristics	Size	L55 x W37 x H24 (mm)
	Weight (including cable)	130g
	Weight (including package)	210g
Interface characteristics	Start delay	<50ms
	Maximum output frequency	100Hz
	Serial communication rate	2400 to 115200 baud rate
	Digital output format	Binary high performance protocol
MTBF	≥ 30000 hours/time	
Electromagnetic compatibility	According to GBT17626	
Insulation resistance	≥ 100 M Ω	
Impact resistance	2000g, 0.5ms, 3 times / axis	

Resolution: The measured minimum change value that the sensor can detect and resolve within the measurement range.

Accuracy: The error between the actual angle and the Root mean square(RMS) of the measured angle of the sensor (≥ 16 times).

Mechanical Characteristic

Connector	Metal connector (standard cable is 1.5m)
Protection level	IP67
Shell material	Magnesium alloy anodizing
Installation	Three M4 screws

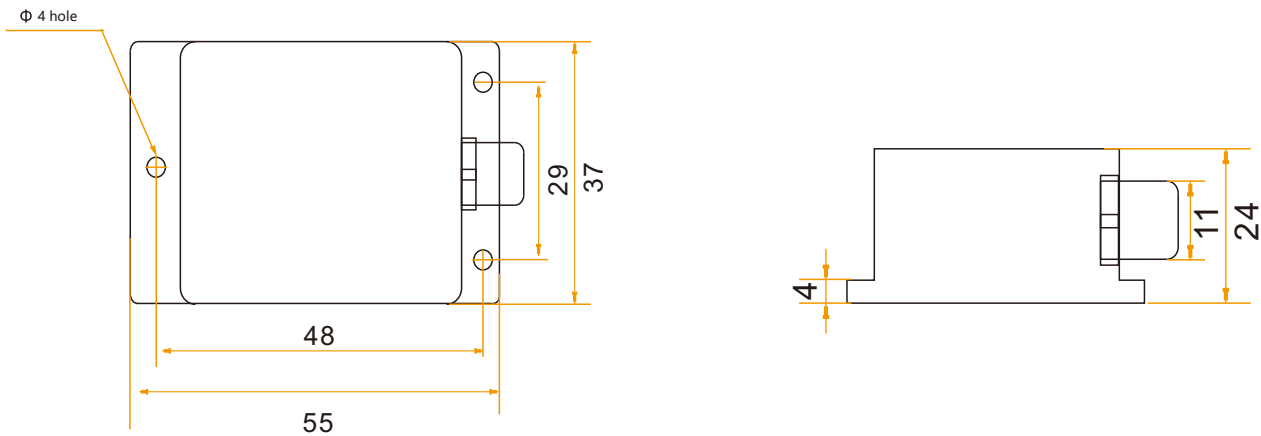

Package size

Product Size: L55*W37*H24 (mm)

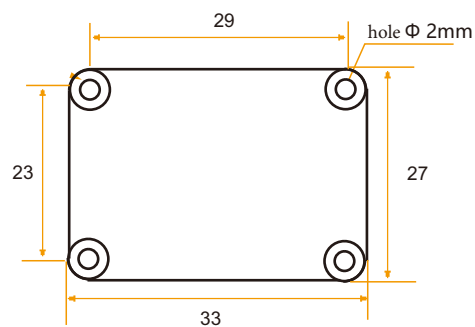

Bare plate product size

Product Size: L33*W27*H6 (mm) ,±1mm error for length and width dimensions, please refer to actual size



Installation direction

The correct installation method can avoid measurement error. The following points should be made when installing the sensor:

First of all, to ensure that the sensor mounting surface and the measured surface completely close, the measured surface should be as horizontal as possible, can not have the angle shown in Figure A and Figure C, the correct installation is shown in Figure B and Figure D.

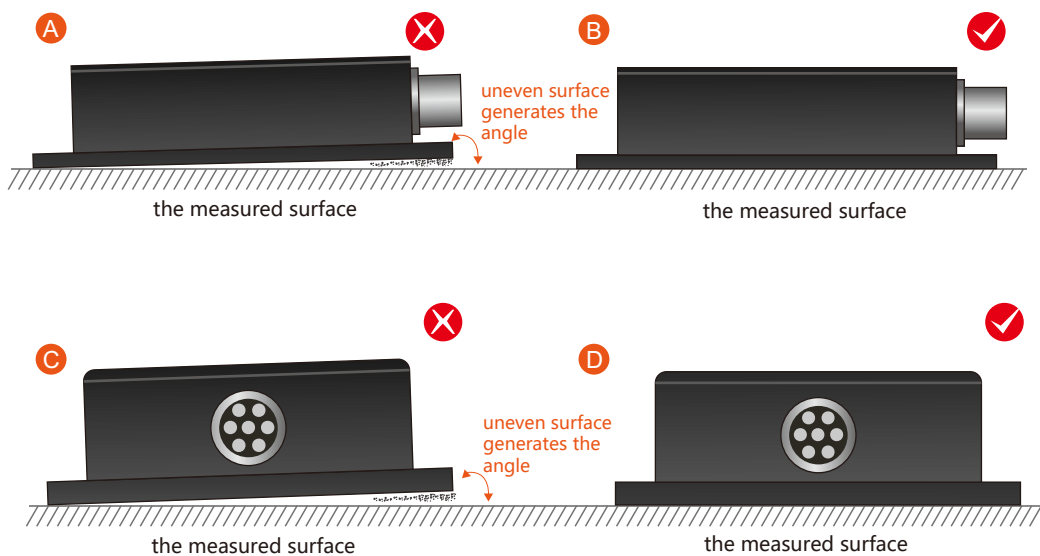

Secondly, the bottom cable of the sensor and the axis of the measured object shouldn't generate the angle shown in E. When installing, the bottom cable of the sensor should be kept parallel or orthogonal to the rotation axis of the measured object. This product can be installed horizontally or vertically (vertical installation requires customization). The correct installation method is shown in Figure F.

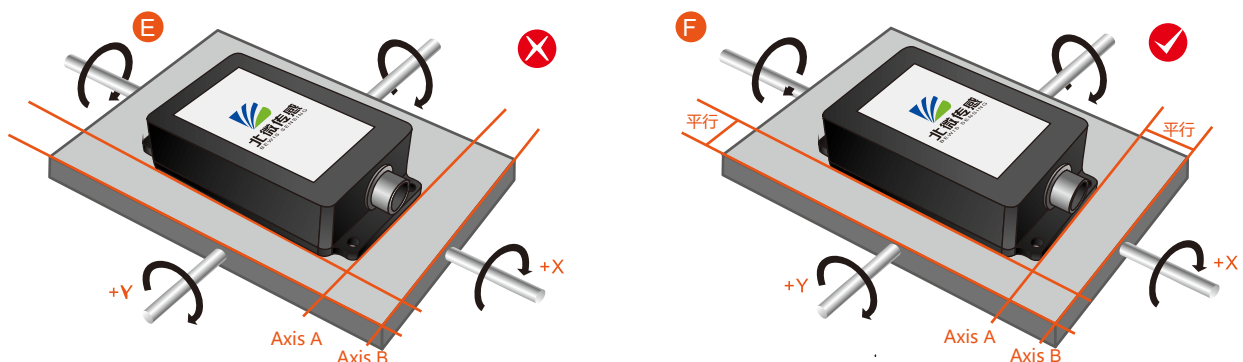

Finally, the installation surface of the sensor must be fixed with the measured surface tightly and smoothly, to avoid measurement error that may be caused by the acceleration and vibration.

Electrical connections

Electrical interfaces

Cable color & function	RED	BLUE	BLACK	GREEN	YELLOW
	1 VCC DC 5V	2 NC	3 GND	4 RXD (B, D-)	5 TXD (A, D+)

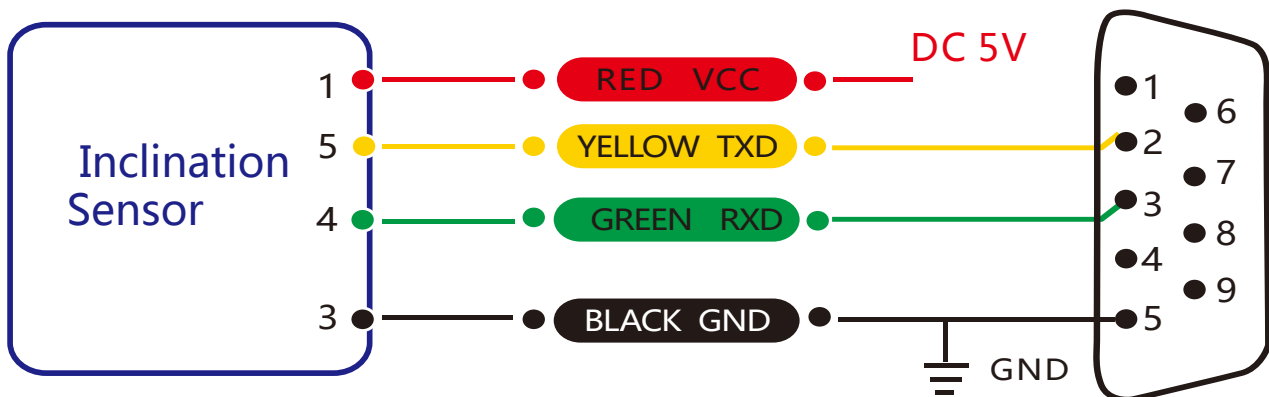
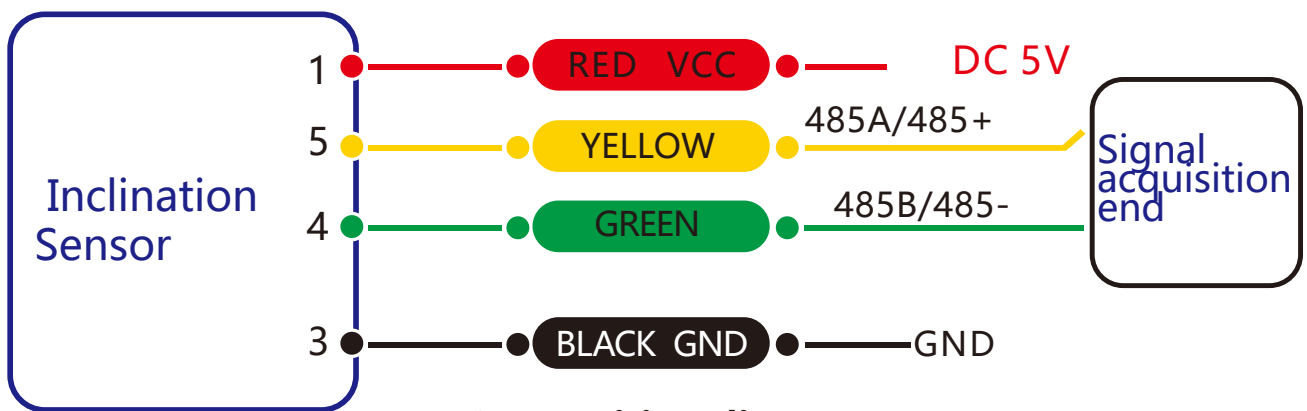

Debug software

Users can directly download serial assistant on official website (Supports-Download). You can also use more convenient and intuitive PC software.

BW-VG50 supporting serial debugging software can be connected to the inclinometer on the computer for angle display. The software debugging interface is as shown in the figure below. Using the debug software, it can conveniently display the current X-direction tilt angle, and you can also modify and set other parameters by yourself.

Software use steps:

- ① Connect the serial port hardware of the inclinometer correctly and connect the power supply.
- ② Select the correct device model (select azimuth series).
- ③ Select the computer serial port and baud rate and click to connect to the serial port.
- ④ Click Start and the tilt angle of the inclinometer in the X and Y directions will be displayed on the screen.

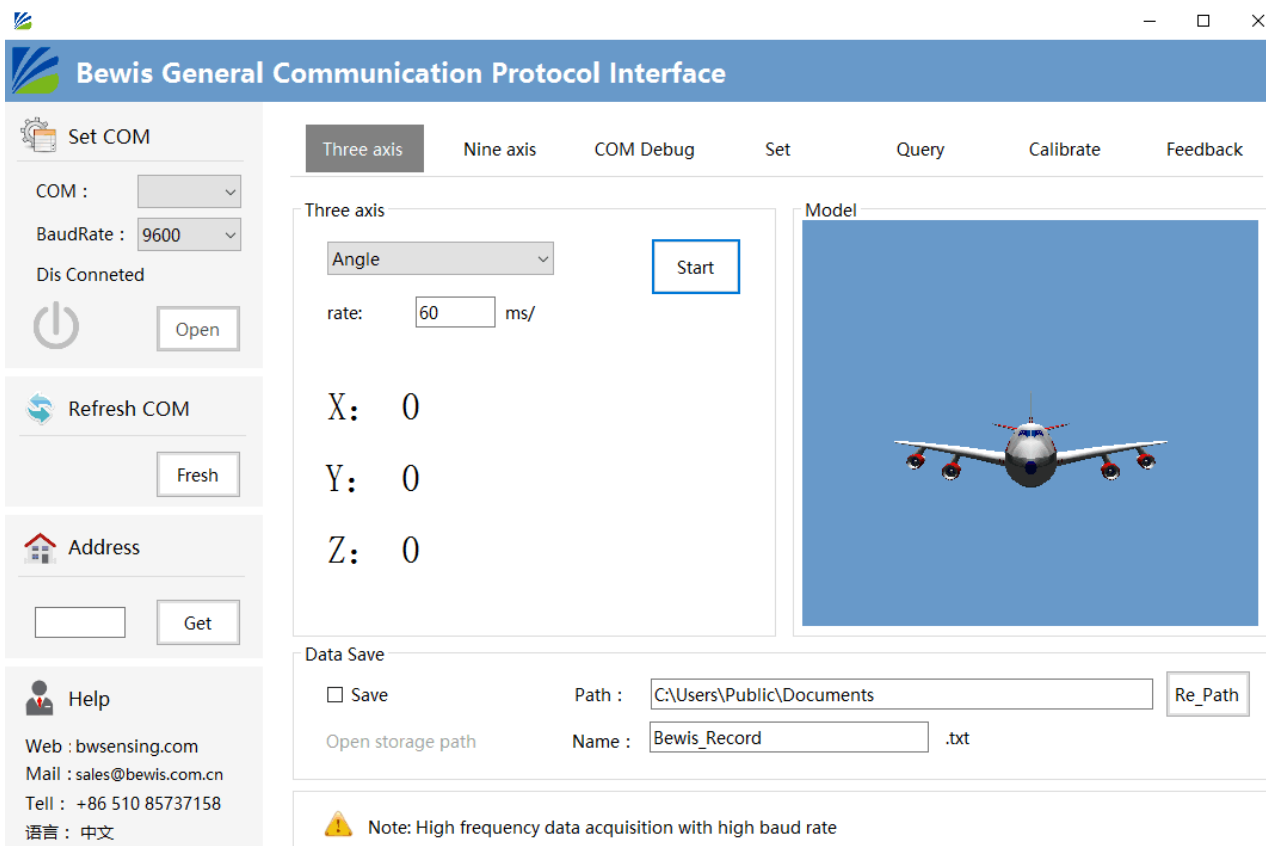

Protocol

1 Data Frame Format: (8 data bits, 1 stop bit, No parity check, default baud rate 9600)

Identifier (1byte)	Frame Length (1byte)	Address Code (1byte)	Command (1byte)	Data (0byte)	Checksum (1byte)
0x77					

Data Format: Hexadecimal

Identifier: Fixed to 77

Frame Length: Length from Frame Length to Checksum (included)

Address Code: Address of acquiring module, default 0x00

Data: Content and length variable according to Command

Checksum: Sum of Frame Length, Address Code, Command and Data. (Please pay attention that when the command or data changes, the checksum will change.)

2 Command Format:

2.1 Read PITCH angle Command: 77 04 00 01 05

Identifier (1byte)	Frame Length (1byte)	Address Code (1byte)	Command (1byte)	Data (0byte)	Checksum (1byte)
0x77	0x04		0x01		0x05

Command response:

Identifier (1byte)	Frame Length (1byte)	Address Code (1byte)	Command (1byte)	Data (3byte)	Checksum (1byte)
0x77	0x07		0x81	SXXX.YY	

Note:The data field is a 3-byte return angle value, which is a compressed BCD code, S is a sign bit (0 positive, 1 negative) XXX is a three-digit integer value, and YY is a two-digit decimal value. The other axis data is the same. For example, 102770 means -27.70 degrees.

2.2 Read ROLL angle Command: 77 04 00 02 06

Identifier (1byte)	Frame Length (1byte)	Address Code (1byte)	Command (1byte)	Data (0byte)	Checksum (1byte)
0x77	0x04		0x02		0x06

Command response:

Identifier (1byte)	Frame Length (1byte)	Address Code (1byte)	Command (1byte)	Data (3byte)	Checksum (1byte)
0x77	0x07		0x82	SXXX.YY	

2.3 Read Heading azimuth angle Command: 77 04 00 04 08

Identifier (1byte)	Frame Length (1byte)	Address Code (1byte)	Command (1byte)	Data (0byte)	Checksum (1byte)
0x77	0x04		0x04		

Command response:

Identifier (1byte)	Frame Length (1byte)	Address Code (1byte)	Command (1byte)	Data (3byte)	Checksum (1byte)
0x77	0x0D		0x84	3 SXXX.YY	

PITCH: +2.01°, ROLL: -0.51°

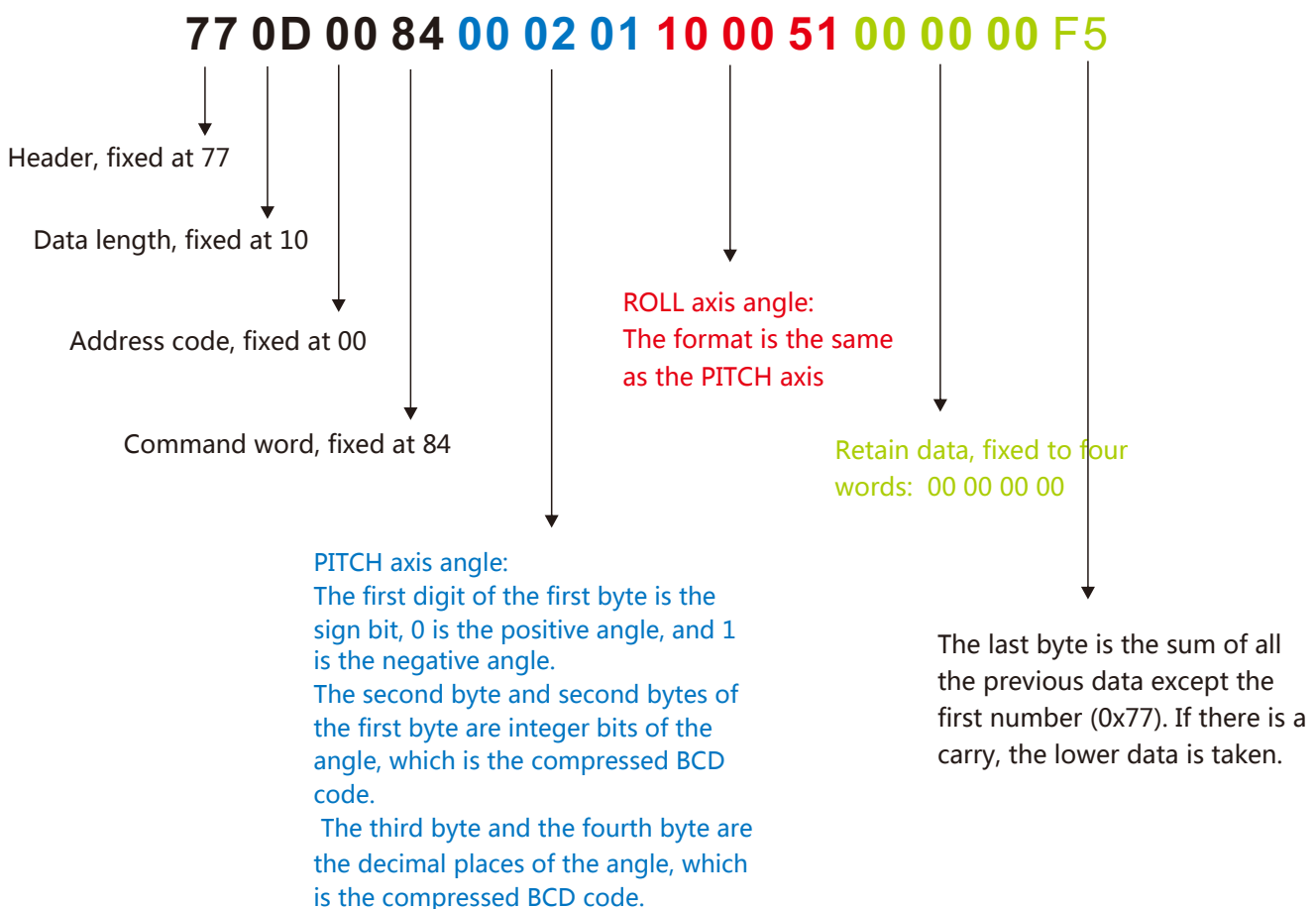

2.4 Set baud rate Command: 77 05 00 0B 02 12

Identifier (1byte)	Frame Length (1byte)	Address Code (1byte)	Command (1byte)	Data (1byte)	Checksum (1byte)
0x77	0x05		0x0B	XX	

Command response:

Identifier (1byte)	Frame Length (1byte)	Address Code (1byte)	Command (1byte)	Data (1byte)	Checksum (1byte)
0x77	0x05		x8B		

Note: 00:2400,01:4800,02:9600,03:19200,04:115200,05:38400,6:57600. If the baud rate is set to 19200, Each time the communication baud rate is changed successfully, the response command is sent back at the original baud rate, and then the device communication baud rate is immediately changed.

Note: If high frequency output is required, set the baud rate to 115200.

2.5 Set address Command: 77 05 00 0F 01 15(Set the module address from 00 to 01)

Identifier (1byte)	Frame Length (1byte)	Address Code (1byte)	Command (1byte)	Data (1byte)	Checksum (1byte)
0x77	0x05		0x0F	XX Address	

Command response:

Identifier (1byte)	Frame Length (1byte)	Address Code (1byte)	Command (1byte)	Data (1byte)	Checksum (1byte)
0x77	0x05	XX	0x0F	YY	

2.6 Query address Command: 77 04 00 1F 23

Identifier (1byte)	Frame Length (1byte)	Address Code (1byte)	Command (1byte)	Data (0byte)	Checksum (1byte)
0x77	0x04	00	0x1F		0x23

Command response:

Identifier (1byte)	Frame Length (1byte)	Address Code (1byte)	Command (1byte)	Data (1byte)	Checksum (1byte)
0x77	0x05	XX	0x1F	XX	

Note: The default address of the sensor is 0x00. When the query address command is sent, the returned data field is the hexadecimal device address.

2.7 Set the automatic output frequency send command: 77 05 00 0C 00 11

Identifier (1byte)	Frame Length (1byte)	Address Code (1byte)	Command (1byte)	Data (0 byte)	Checksum (1byte)
0x77	0x05		0x0C	XX	

Command response:

Identifier (1byte)	Frame Length (1byte)	Address Code (1byte)	Command (1byte)	Data (1byte)	Checksum (1byte)
0x77	0x05		0x8C	0x00	

The data field XX sent is the automatic output frequency option.:

- 00 indicates the answer mode
- 01 means 5Hz automatic output triaxial angle
- 02 means 10Hz automatic output triaxial angle
- 03 means 20Hz automatic output triaxial angle
- 04 means 25Hz automatic output triaxial angle
- 05 means 50Hz automatic output triaxial angle
- 06 means 100Hz automatic output triaxial angle

When the automatic output frequency setting is high, the baud rate needs to be set to a high baud rate.

2.8 Save setting Command: 77 04 00 0A 0E

Identifier (1byte)	Frame Length (1byte)	Address Code (1byte)	Command (1byte)	Data (0 byte)	Checksum (1byte)
0x77	0x04		0x0A		

Command response:

Identifier (1byte)	Frame Length (1byte)	Address Code (1byte)	Command (1byte)	Data (1byte)	Checksum (1byte)
0x77	0x05		0x8A	0x00	

Ordering Information

Product number	Way of communication	Package condition
BW-VG50-232	RS232	IP67 Package/Metal Connector
BW-VG50-485	RS485	IP67 Package/Metal Connector
BW-VG50-TTL	TTL	IP67 Package/Metal Connector
BW-VG50-CAN	CAN	IP67 Package/Metal Connector

Executive standard

- Enterprise Quality System Standard: ISO9001:2008 Standard (Certificate No.:10114Q16846ROS)
- CE certification (certificate number: 3854210814)
- ROHS (certificate number: SO81426003)
- GB/T 191 SJ 20873-2003 General specifications for tiltmeters and spirit levels
- GBT 18459-2001 sensor main static performance index calculation method
- JF 1059-1999 Evaluation and Expression of Measurement Uncertainty
- GBT 14412-2005 mechanical vibration and shock mechanical installation of accelerometer
- General requirements for GJB 450A-2004 equipment reliability
- Quality control of key parts and important parts of GJB 909A
- GJB 899 Reliability Qualification and Acceptance Test
- GJB 150-3A high temperature test
- GJB 150-4A low temperature test
- GJB 150-8A rain test
- GJB 150-12A dust test
- GJB 150-16A vibration test
- GJB 150-18A impact test
- GJB 150-23A Tilt and Swing Test
- GB/T 17626-3A RF electromagnetic radiation immunity test
- GB/T 17626-5A surge (hit) impulse immunity test
- GB/T 17626-8A power frequency magnetic field immunity test
- GB/T 17626-11A voltage dips, short interruptions and voltage changes immunity

BW-VG50

Low Cost Digital Dynamic Inclination Sensor

Wuxi Bewis Sensing Technology LLC

Address: Building 30, No. 58 Xiuxi Road, Binhu District, Wuxi City

Hotline: 400-618-0510

Tel: +86 510 85737178-801

Email: sales@bwsensing.com

Website: www.bwsensing.com