

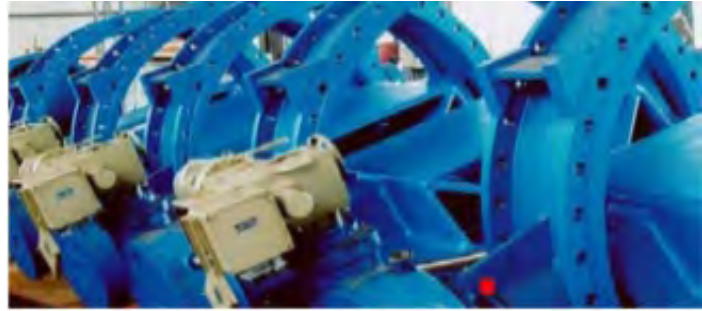

BWK210 Series

Voltage Single-Axis Inclinometer

Technical Manual



Introduction

Designed by Bewis Sensing Technology LLC, BWK210 is a voltage output low cost single-axis inclinometer, adopting the latest industrial level MEMS accelerometer. Its measuring range is $\pm 180^\circ$, highest accuracy is 0.2° , working temperature is $-40^\circ\text{C}\sim+85^\circ\text{C}$, the product with a small size and low weight, can meet space-restricted application requirements.

This product converts static gravity field changes into angle changes, It outputs horizontal angle values directly by voltage, this product has the advantages of low cost, small temperature drift, simple to use, and strong resistance to external disturbances. It is an ideal option for attitude measurement in photovoltaic power(PV) , PTZ control, tower turbines monitoring and other industries.

Features

- Single-axis inclination measurement
- Resolution: 0.02°
- Voltage input: $12\sim 35\text{V}$
- Small size: $L90\text{mm}\times W40.5\text{mm}\times H26\text{mm}$ (customizable)
- Accuracy: 0.2°
- Measuring range: $\pm 180^\circ$
- IP67 protection
- Output mode: $0\sim 5\text{V}/0\sim 10\text{V}$ optional

Applications

- Industrial automatic leveling
- Medical devices
- The automatic tracking system of solar angle
- Tower tilt monitoring
- Special valves
- Oil drilling equipment
- Industrial converters
- Crane tilt angle control

Specifications

Electrical Specifications

Parameters	Conditions	Min	Typical	Max	Units
Power supply		12		35	V
Operating current	Non-loaded	20(35V supply voltage)	50	60	mA
Output load	Resistivity	10			KΩ
	Capacitive			20	nF
Operating temperature		-40		+85	°C
Store temperature		-55		+100	°C

Mechanical Specifications

Measuring range(°)	Conditions	±10	±30	±60	±90	±180
Measuring axis		X	X	X	X	X
Accuracy(°)	Indoor	0.2	0.2	0.2	0.2	0.2
Resolution(°)		0.02	0.02	0.02	0.02	0.02
Zero temperature drift(°/°C)	-40 ~ 85°C	±0.01	±0.01	±0.01	±0.01	±0.01
Frequency response (Hz)	5 ~ 100Hz	Up to 100	Up to 100	Up to 100	Up to 100	Up to 100
Zero point output (V)		2.5 (0 ~ 5 output)				
		5 (0 ~ 10 output)				
Full scale output voltage		0~5 (0~10)				
MTBF		≥ 30000 hours/time				
Electromagnetic compatibility		according to GBT17626				
Insulation resistance		≥100MΩ				
Shock resistance		2000g,0.5ms,3times/axis				
Weight (g)		230 (package excluded)				

Resolution: The measured minimum change value that the sensor can detect and resolve within the measurement range.

Accuracy: The error between the actual angle and the Root mean square(RMS) of the measured angle of the sensor (≥16 times).

Mechanical Characteristic

Connector	Metal connector (standard cable is 1.5m)
Protection level	IP67
Shell material	Magnesium alloy anodizing
Installation	Four M4 screws

Product Size

Product Size: L90*W40.5*H26(mm)

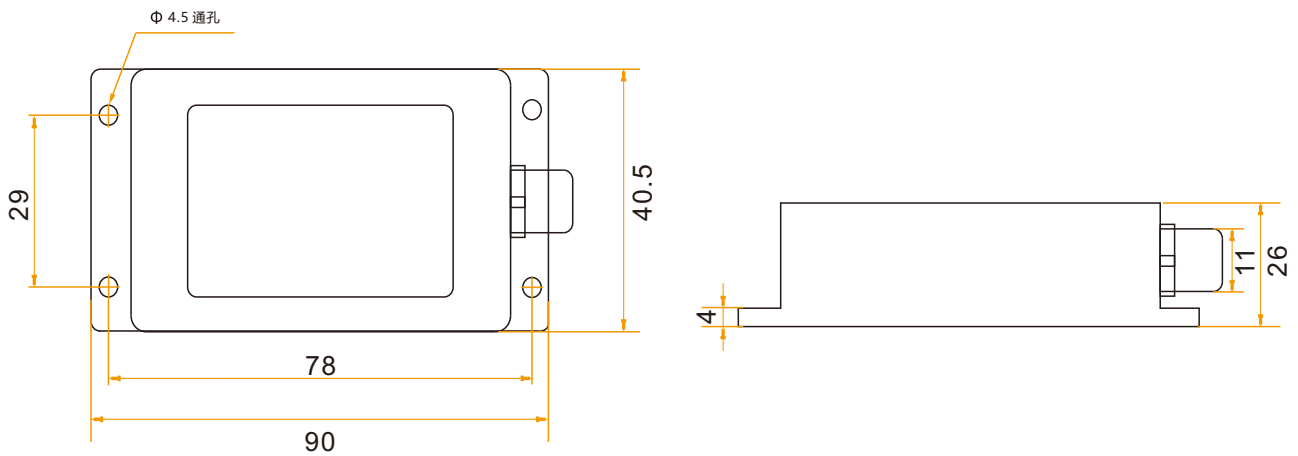

Product Size

Product size: L47*W36*H15(mm)

Note: ± 1 mm error for length and width dimensions, please refer to actual size.

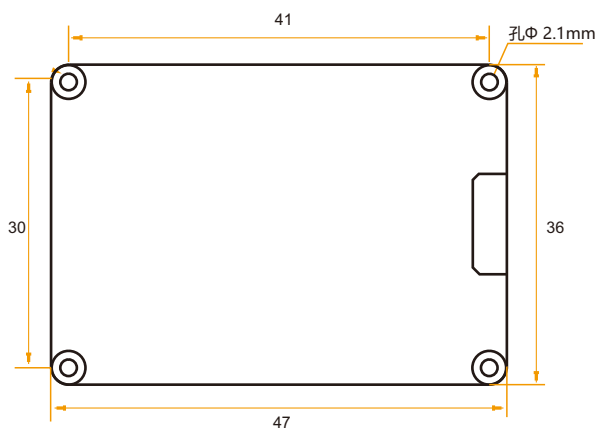

Installation direction

The correct installation method can avoid measurement error. The following points should be made when installing the sensor:

First of all, to ensure that the sensor mounting surface and the measured surface completely close, the measured surface should be as horizontal as possible, can not have the angle shown in Figure A and Figure C, the correct installation is shown in Figure B and Figure D.

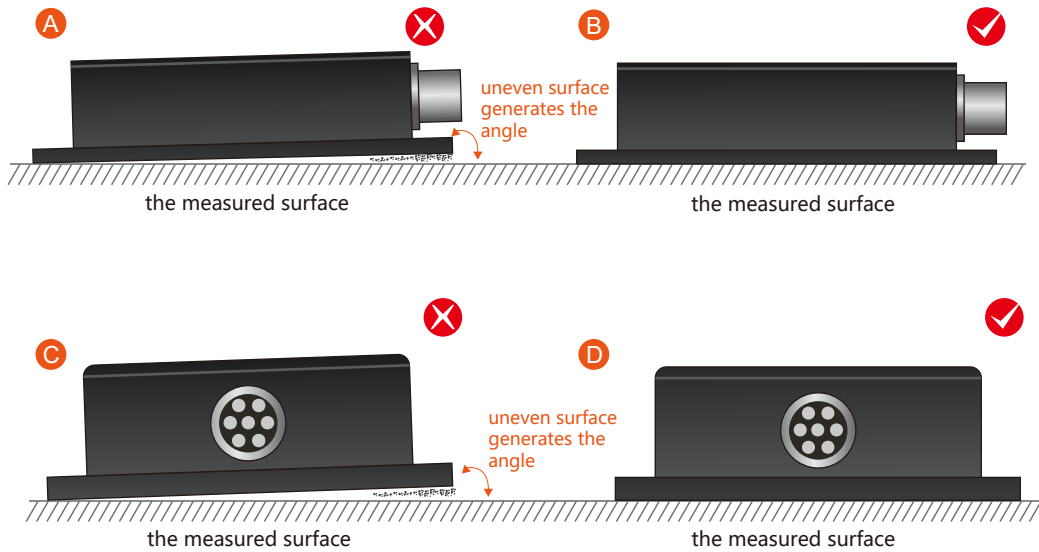

Secondly, the bottom cable of the sensor and the axis of the measured object shouldn't generate the angle shown in E. When installing, the bottom cable of the sensor should be kept parallel or orthogonal to the rotation axis of the measured object. This product can be installed horizontally or vertically (vertical installation requires customization). The correct installation method is shown in Figure F.

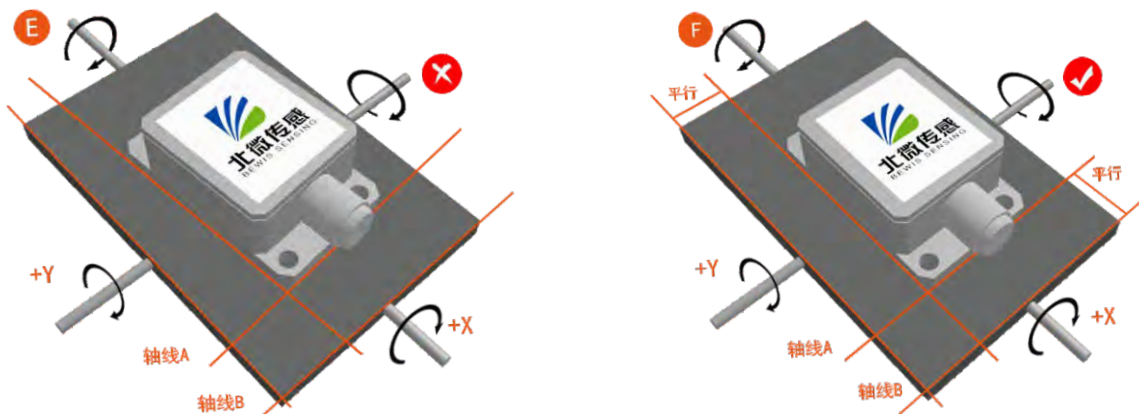

Finally, the installation surface of the sensor must be fixed with the measured surface tightly and smoothly, to avoid measurement error that may be caused by the acceleration and vibration.

Electrical connections

Electrical interfaces

Cable color & Function	RED	BLACK	GREEN	YELLOW	BROWN	GRAY
	1	3	4	5	8	10
	VCC DC 12-35V	GND	RS232 RXD	RS232 TXD	U XOUT	Output ground

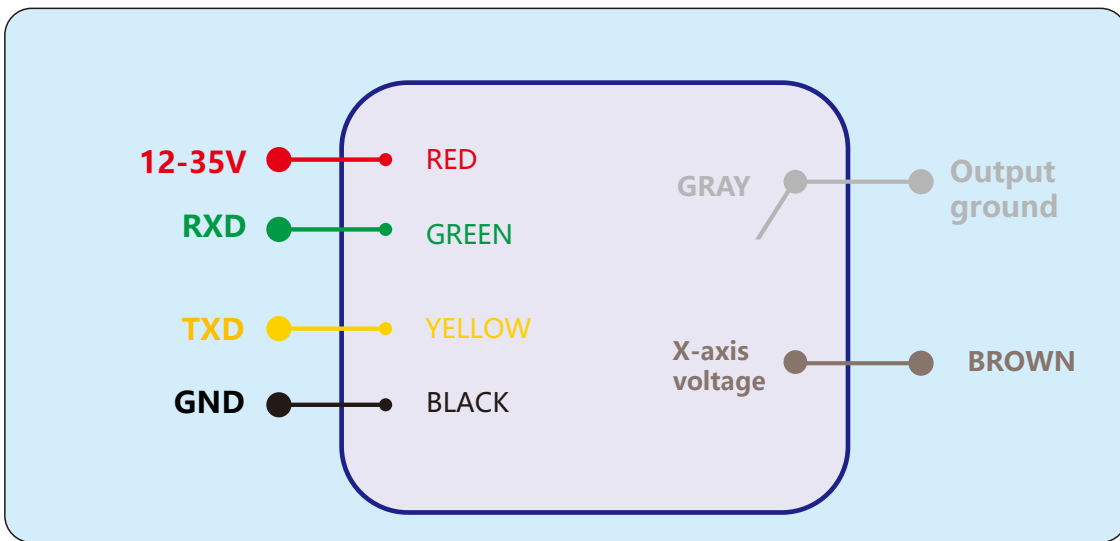

Electrical interfaces

Cable color & Function	RED	BLUE	BLACK	GREEN	YELLOW
	1	2	3	4	5
	VCC DC 12-35V	NC	GND	RS232 RXD	RS232 TXD

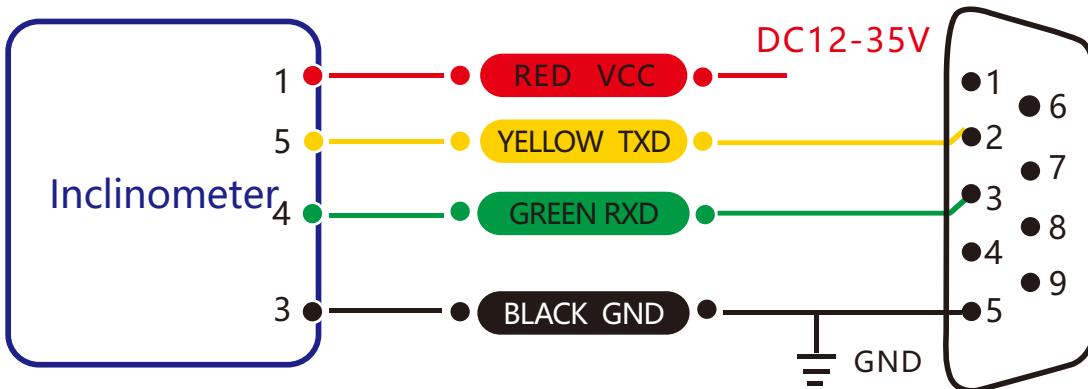

RS 232 wiring diagram

Debug software

Users can directly download serial assistant on official website (Supports-Download). You can also use more convenient and intuitive PC software.

BWK210 supporting serial debugging software can be connected to the inclinometer on the computer for angle display. The software debugging interface is as shown in the figure below. Using the debug software, it can conveniently display the current X-direction tilt angle, and you can also modify and set other parameters by yourself.

Software use steps:

- ① Correctly connect the inclinometer serial port hardware and connect the power supply.
- ② Select the computer serial port and baud rate and click connect Serial Port.
- ③ Click Start and the tilt angle of the tilter in the X direction will be displayed on the screen.

Note: You can switch to Chinese or English version by the bottom left button.

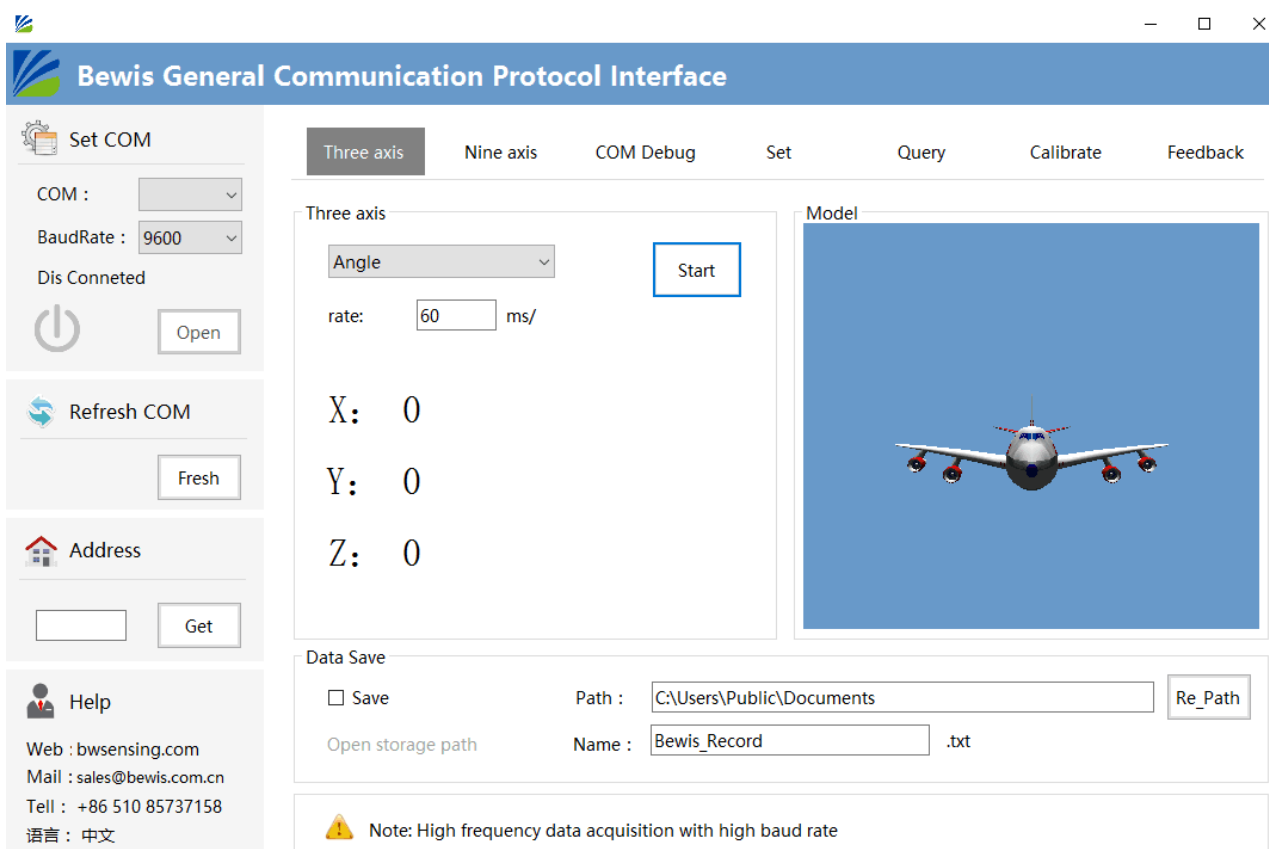

Protocol

1 Data Frame Format: (8 data bits, 1 stop bit, No parity check, default baud rate 9600)

Identifier (1byte)	Frame Length (1byte)	Address Code (1byte)	Command (1byte)	Data	Checksum (1byte)
0x77					

Data Format: Hexadecimal

Identifier: Fixed to 77

Frame Length: Length from Frame Length to Checksum (included)

Address Code: Address of acquiring module, default 0x00

Data: Content and length variable according to Command

Checksum: Sum of Frame Length, Address Code, Command and Data. (Please pay attention that when the command or data changes, the checksum will change.)

2 Command Format:

2.1 Read angle of X axis Command: 77 04 00 01 05

Identifier (1byte)	Frame Length (1byte)	Address Code (1byte)	Command (1byte)	Data (0byte)	Checksum (1byte)
0x77			0x01		

Command response:

Identifier (1byte)	Frame Length (1byte)	Address Code (1byte)	Command (1byte)	Data (3byte)	Checksum (1byte)
0x77	0x07		0x81	SXXX.YY	

Note: Data represents 3 byte angle value in format of compressed BCD code. S is the sign bit (0 means positive, 1 means negative), XXX is the three digit integer part, YY is the fractional part. The Data of other axis is the same format. For example, 102770 means -027.7 °.

2.2 Set address Command: 77 05 00 0F 01 15

Identifier (1byte)	Frame Length (1byte)	Address Code (1byte)	Command (1byte)	Data (1byte)	Checksum (1byte)
0x77			0x0F	XX Address	

Command response:

Identifier (1byte)	Frame Length (1byte)	Address Code (1byte)	Command (1byte)	Data (1byte)	Checksum (1byte)
0x77		XX Address	0x8F	0x00: success 0xFF: failure	

2.3 Set relative / absolute zero Command: 77 05 00 05 00 0A

Identifier (1byte)	Frame Length (1byte)	Address Code (1byte)	Command (1byte)	Data (1byte)	Checksum (1byte)
0x77			0x05	0x00: absolute zero 0x01: relative zero	

Command response:

Identifier (1byte)	Frame Length (1byte)	Address Code (1byte)	Command (1byte)	Data (1byte)	Checksum (1byte)
0x77			0x85	0x00: success 0xFF: failure	

Note: absolute zero: Based on the factory-calibrated zero point.

relative zero: I \j\i\veZ\ kf 'k_\`q\if 'Xjki 'k_\`Zi ii\ek`ej kXkf e%

2.4 Query relative / absolute zero Command: 77 04 00 0D 11

Identifier (1byte)	Frame Length (1byte)	Address Code (1byte)	Command (1byte)	Data (0byte)	Checksum (1byte)
0x77			0x0D		

Command response:

Identifier (1byte)	Frame Length (1byte)	Address Code (1byte)	Command (1byte)	Data (1byte)	Checksum (1byte)
0x77			0x8D	0x00: absolute zero 0xFF: relative zero	

2.5 Set baud rate Command: 77 05 00 0B 03 13

Identifier (1byte)	Frame Length (1byte)	Address Code (1byte)	Command (1byte)	Data (1byte)	Checksum (1byte)
0x77			0x0B		

Command response:

Identifier (1byte)	Frame Length (1byte)	Address Code (1byte)	Command (1byte)	Data (1byte)	Checksum (1byte)
0x77			0x8B	0x00: success 0xFF: failure	

Note: For data, 00: 2400, 01: 4800, 02: 9600, 03: 19200, 04 115200, Default 02:9600.

Note: Set baud rate to 115200 in high speed mode. When the Set baud rate command is executed successfully, the command response will be return in the original baud rate and then communicate with new baud rate.

2.6 Set output mode Command: 77 05 00 0C 00 11

Identifier (1byte)	Frame Length (1byte)	Address Code (1byte)	Command (1byte)	Data (1byte)	Checksum (1byte)
0x77			0x0C	0x00: question and answer Mode 0x01: 5Hz Data Rate 0x02: 10Hz Data Rate 0x03: 20Hz Data Rate 0x04: 25Hz Data Rate 0x05: 50Hz Data Rate 0x06: 100Hz Data Rate	

Note: The default output mode is 00(when setting 100HZ output frequency.
 Set baud rate to 115200 in high speed mode.

Command response:

Identifier (1byte)	Frame Length (1byte)	Address Code (1byte)	Command (1byte)	Data (1byte)	Checksum (1byte)
0x77	0x05		0x8C	0x00: success 0xFF: failure	

Note: 5Hz Data Rate means that 5 sets of angle data are automatically output every second, and so on.

2.7 Save setting Command: 77 04 00 0A 0E

Identifier (1byte)	Frame Length (1byte)	Address Code (1byte)	Command (1byte)	Data (1byte)	Checksum (1byte)
0x77			0x0A		

Command response:

Identifier (1byte)	Frame Length (1byte)	Address Code (1byte)	Command (1byte)	Data (1byte)	Checksum (1byte)
0x77	0x05		0x8A	0x00: success 0xFF: failure	

Note: If Save setting command is not executed, all setting will be invalid after power off.

2.8 Query address Command: 77 04 00 1F 23

Identifier (1byte)	Frame Length (1byte)	Address Code (1byte)	Command (1byte)	Data (0byte)	Checksum (1byte)
0x77			0x1F		

Command response:

Identifier (1byte)	Frame Length (1byte)	Address Code (1byte)	Command (1byte)	Data (1byte)	Checksum (1byte)
0x77			0x1F	XX	

Ordering Information

Product number	Output voltage range	Way of communication	Package condition
BWK210-180-05	0~5V	RS232	IP67 Package/Metal Connector
BWK210-180-010	0~10V	RS232	IP67 Package/Metal Connector

Executive standard

- Enterprise Quality System Standard: ISO9001:2008 Standard (Certificate No.:10114Q16846ROS)
- CE certification (certificate number: 3854210814)
- ROHS (certificate number: SO81426003)
- GB/T 191 SJ 20873-2003 General specifications for tiltmeters and spirit levels
- GBT 18459-2001 sensor main static performance index calculation method
- JF 1059-1999 Evaluation and Expression of Measurement Uncertainty
- GBT 14412-2005 mechanical vibration and shock mechanical installation of accelerometer
- General requirements for GJB 450A-2004 equipment reliability
- Quality control of key parts and important parts of GJB 909A
- GJB 899 Reliability Qualification and Acceptance Test
- GJB 150-3A high temperature test
- GJB 150-4A low temperature test
- GJB 150-8A rain test
- GJB 150-12A dust test
- GJB 150-16A vibration test
- GJB 150-18A impact test
- GJB 150-23A Tilt and Swing Test
- GB/T 17626-3A RF electromagnetic radiation immunity test
- GB/T 17626-5A surge (hit) impulse immunity test
- GB/T 17626-8A power frequency magnetic field immunity test
- GB/T 17626-11A voltage dips, short interruptions and voltage changes immunity

BWK210 Serials

Voltage Single-Axis Inclinator

Wuxi Bewis Sensing Technology LLC

Address: Building 30, No. 58 Xiuxi Road, Binhu District, Wuxi City

Hotline: 400-618-0510

Tel: +86 510 85737158

Email: sales@bwsensing.com

Website: www.bwsensing.com