



# BWK216 Serials

## Digital Single-Axis Inclinometer

### Technical Manual



## Introduction

Designed by Bewis Sensing Technology LLC, BWK216 is a digital output low cost single-axis inclinometer, adopting the latest industrial level MEMS accelerometer. Its measuring range is  $\pm 180^\circ$ , highest accuracy is  $0.2^\circ$ , working temperature is  $-40^\circ\text{C}\sim+85^\circ\text{C}$ , the product with a small size and low weight, can meet space-restricted application requirements.

This product converts static gravity field changes into angle changes, It outputs horizontal angle values directly by digital, this product has the advantages of low cost, small temperature drift, simple to use, and strong resistance to external disturbances. It is an ideal option for attitude measurement in photovoltaic power (PV) , PTZ control, tower turbines monitoring and other industries.

## Features

- Single-axis inclinometer measurement
- Resolution:  $0.02^\circ$
- Voltage input: 9~35V
- Product size: L90mm×W40.5mm×H26mm (customizable)
- Accuracy:  $0.2^\circ$
- Measuring range:  $\pm 180^\circ$
- IP67 protection
- Output interface: RS232/485/TTL optional

## Applications

- Industrial automatic leveling
- Medical devices
- The automatic tracking system of solar angle
- Tower tilt monitoring
- Special valves
- Oil drilling equipment
- Industrial converters
- Crane tilt angle control

## Specifications

### Electrical Specifications

| Parameters            | Conditions | Min | Typical | Max  | Units |
|-----------------------|------------|-----|---------|------|-------|
| Power supply          |            | 9   | 12      | 35   | V     |
| Operating current     | Non-loaded | 20  | 30      | 40   | mA    |
| Operating temperature |            | -40 |         | +85  | °C    |
| Store temperature     |            | -55 |         | +100 | °C    |

### Performance Specifications

| Measuring range(°)            | Conditions              | ±10   | ±30   | ±60   | ±90   | ±180  |
|-------------------------------|-------------------------|-------|-------|-------|-------|-------|
| Measuring axis                |                         | X     | X     | X     | X     | X     |
| Accuracy(°)                   | Indoor                  | 0.2   | 0.2   | 0.2   | 0.2   | 0.2   |
| Resolution(°)                 |                         | 0.02  | 0.02  | 0.02  | 0.02  | 0.02  |
| Zero temperature drift(°/°C)  | -40 ~ 85°C              | ±0.01 | ±0.01 | ±0.01 | ±0.01 | ±0.01 |
| Frequency response (Hz)       |                         | 100   | 100   | 100   | 100   | 100   |
| Baud rate                     | 2400~115200             |       |       |       |       |       |
| MTBF                          | ≥ 30000 hours/time      |       |       |       |       |       |
| Electromagnetic compatibility | according to GBT17626   |       |       |       |       |       |
| Insulation resistance         | ≥100MΩ                  |       |       |       |       |       |
| Shock resistance              | 2000g,0.5ms,3times/axis |       |       |       |       |       |
| Weight (g)                    | 210g (package excluded) |       |       |       |       |       |

**Resolution:** The measured minimum change value that the sensor can detect and resolve within the measurement range.

**Accuracy:** The error between the actual angle and the Root mean square(RMS) of the measured angle of the sensor (≥16 times).

### Mechanical Characteristic

|                  |  |
|------------------|--|
| Connector        | Metal connector (standard cable is 1.5m) |
| Protection level | IP67                                     |
| Shell material   | Magnesium alloy anodizing                |
| Installation     | Four M4 screws                           |

### Package size

Product Size: L90\*W40.5\*H26 (mm)

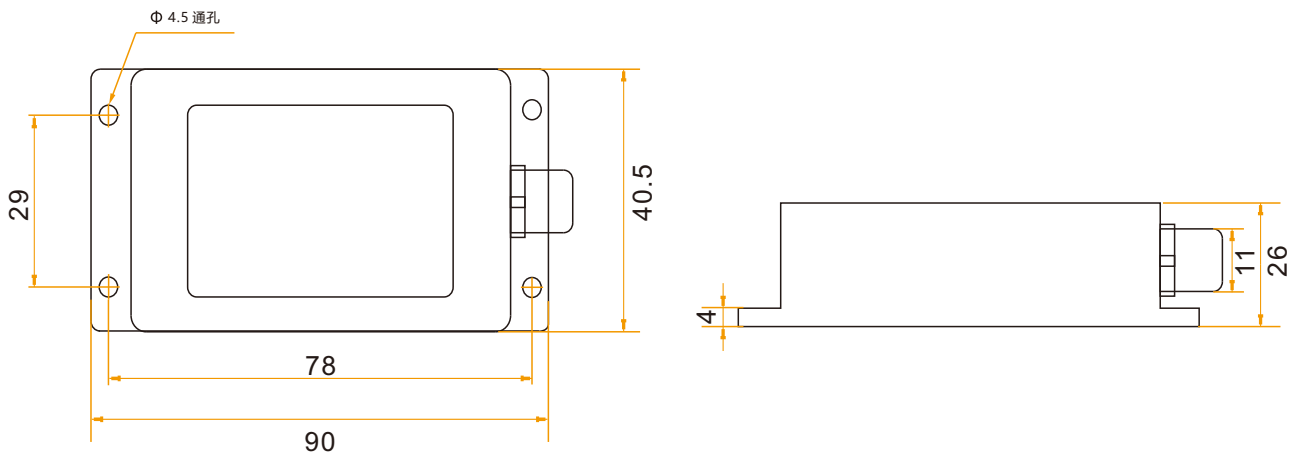

### Bare plate product size

Product size: L47\*W36\*H15(mm)

**Note:**  $\pm 1$ mm error for length and width dimensions, please refer to actual size.

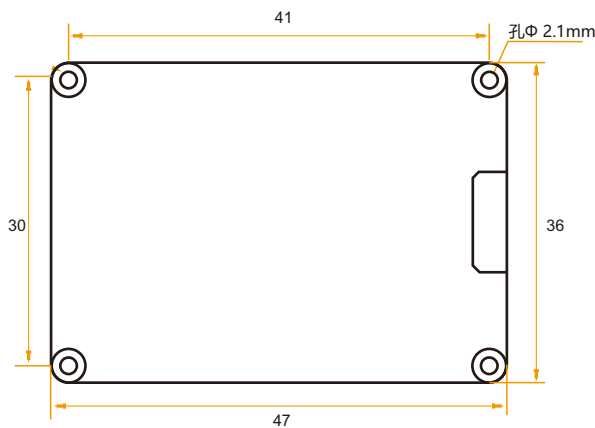

## Installation direction

The correct installation method can avoid measurement error. The following points should be made when installing the sensor:

First of all, to ensure that the sensor mounting surface and the measured surface completely close, the measured surface should be as horizontal as possible, can not have the angle shown in Figure A and Figure C, the correct installation is shown in Figure B and Figure D.

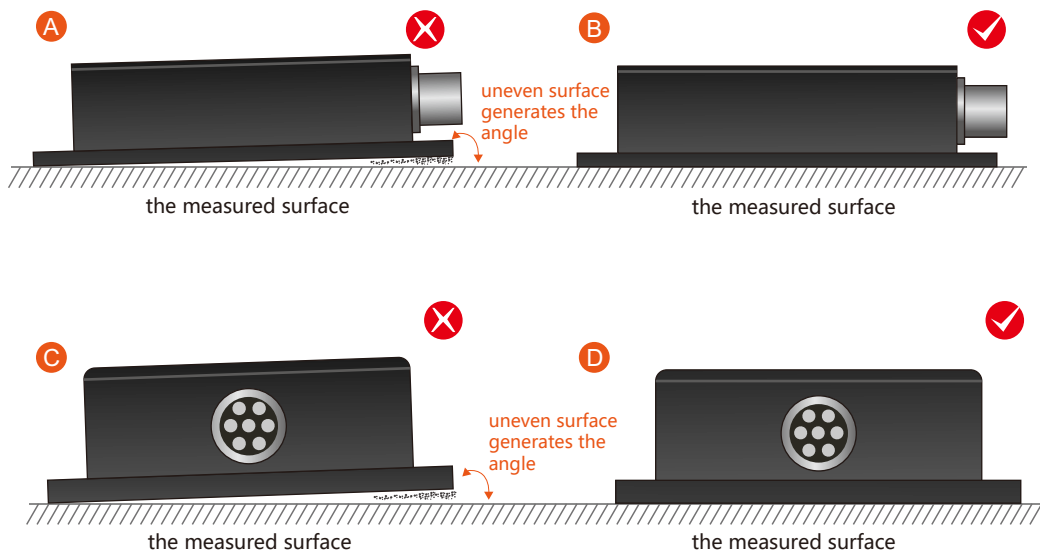

Secondly, the bottom cable of the sensor and the axis of the measured object shouldn't generate the angle shown in E. When installing, the bottom cable of the sensor should be kept parallel or orthogonal to the rotation axis of the measured object. This product can be installed horizontally or vertically (vertical installation requires customization). The correct installation method is shown in Figure F.

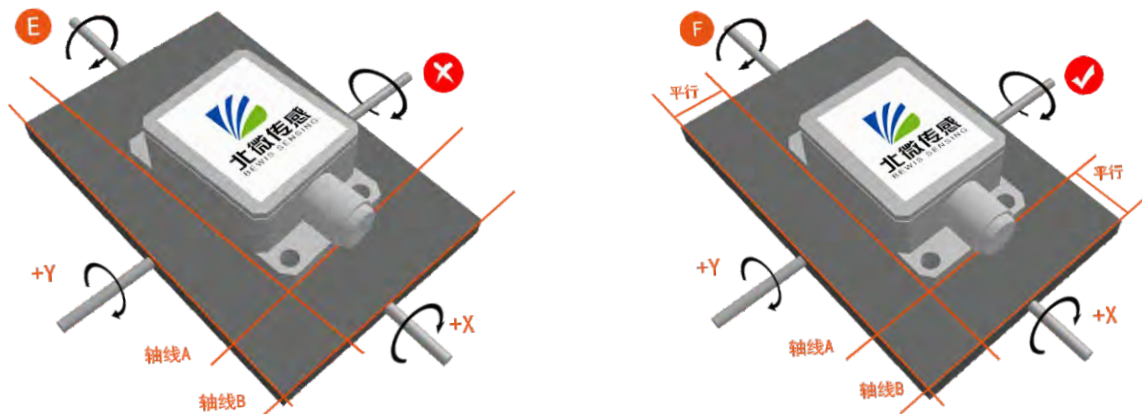

Finally, the installation surface of the sensor must be fixed with the measured surface tightly and smoothly, to avoid measurement error that may be caused by the acceleration and vibration.

## Electrical connections

### Electrical interfaces

| Cable color & Function | RED             | BLUE | BLACK | GREEN          | YELLOW         |
|------------------------|-----------------|------|-------|----------------|----------------|
|                        | 1               | 2    | 3     | 4              | 5              |
|                        | VCC<br>DC 9-35V | NC   | GND   | RXD<br>(B, D-) | TXD<br>(A, D+) |

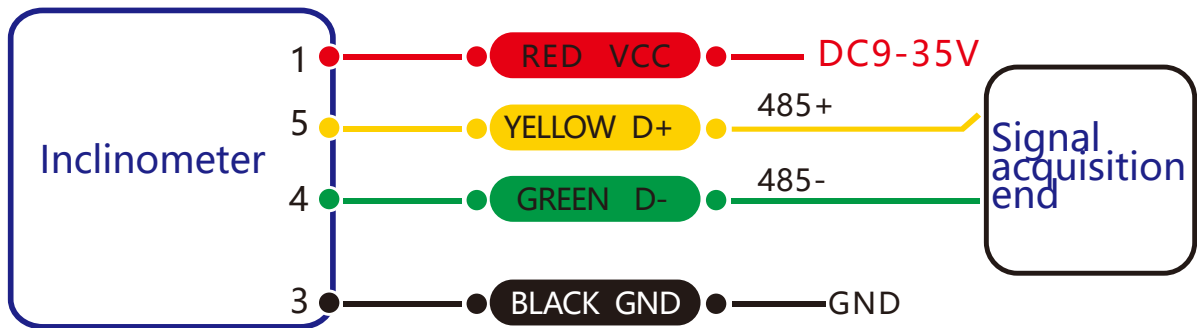

**RS 485 wiring diagram**

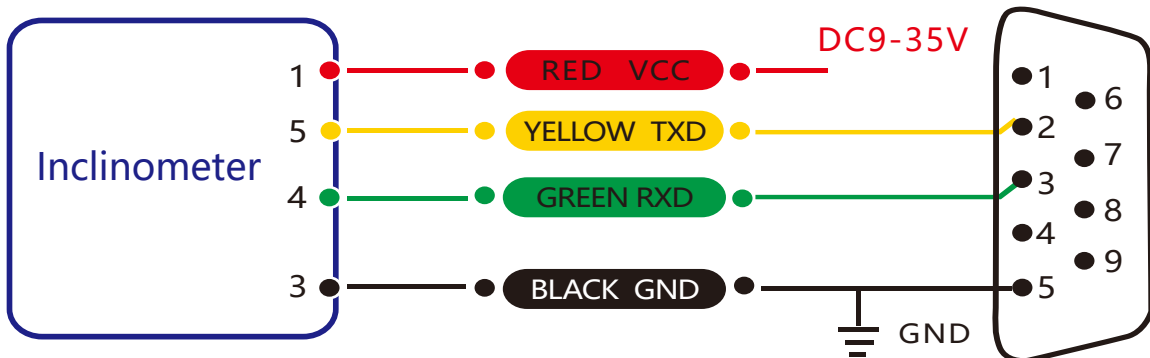

**RS 232 wiring diagram**

## Debug software

Users can directly download serial assistant on official website (Supports-Download). You can also use more convenient and intuitive PC software.

BWK216 supporting serial debugging software can be connected to the inclinometer on the computer for angle display. The software debugging interface is as shown in the figure below. Using the debug software, it can conveniently display the current X-direction tilt angle, and you can also modify and set other parameters by yourself.

### Software use steps:

- ① Correctly connect the inclinometer serial port hardware and connect the power supply.
- ② Select the computer serial port and baud rate and click connect Serial Port.
- ③ Click Start and the tilt angle of the tilter in the X direction will be displayed on the screen.

**Note:** You can switch to Chinese or English version by the bottom left button.

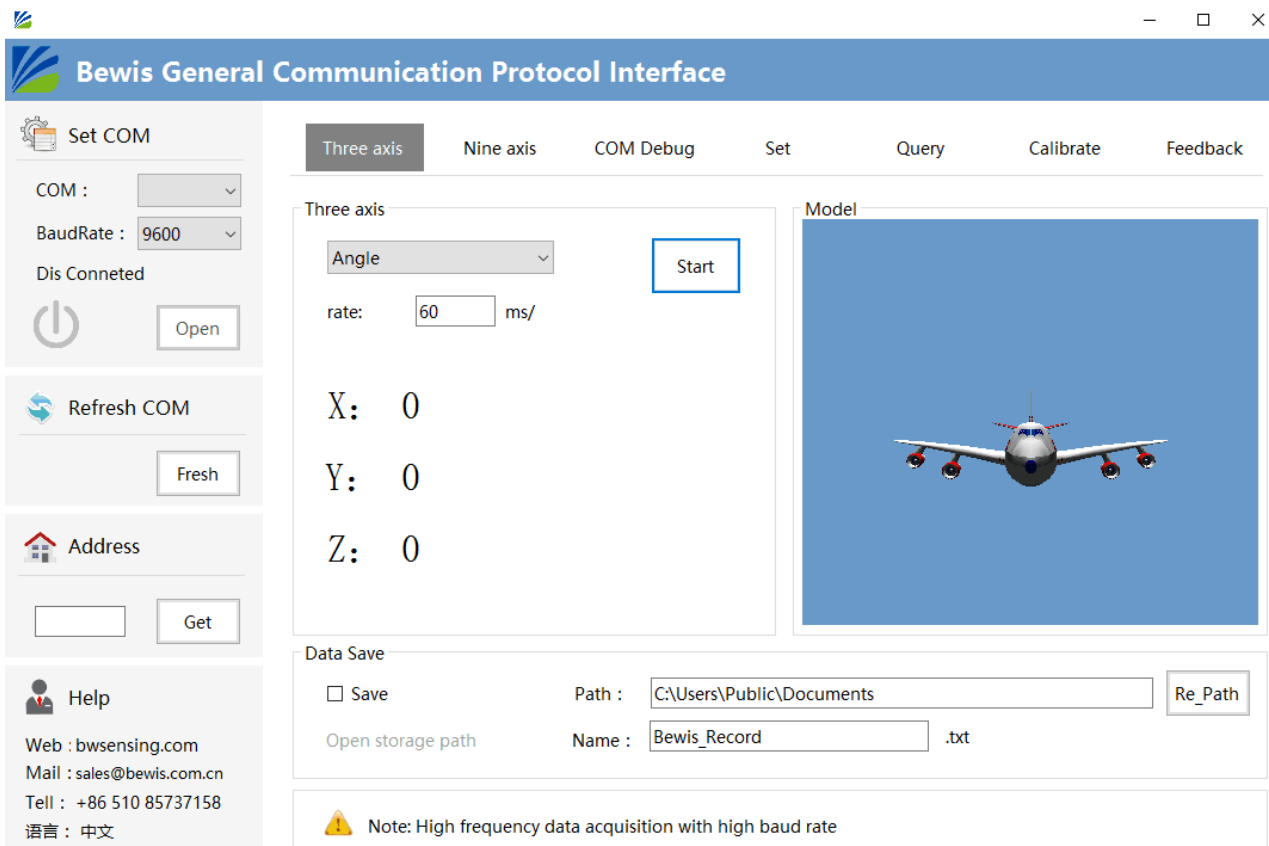

## Protocol

### 1 Data Frame Format: (8 data bits, 1 stop bit, No parity check, default baud rate 9600)

| Identifier (1byte) | Frame Length (1byte) | Address Code (1byte) | Command (1byte) | Data (xx byte) | Checksum (1byte) |
|--------------------|----------------------|----------------------|-----------------|----------------|------------------|
| 0x77               |                      |                      |                 |                |                  |

**Data Format:** Hexadecimal

**Identifier:** Fixed to 77

**Frame Length:** Length from Frame Length to Checksum (included)

**Address Code:** Address of acquiring module, default 0x00

**Data:** Content and length variable according to Command

**Checksum:** Sum of Frame Length, Address Code, Command and Data. (Please pay attention that when the command or data changes, the checksum will change.)

### 2 Command Format

#### 2.1 Read angle of X axis Command: 77 04 00 01 05

| Identifier (1byte) | Frame Length (1byte) | Address Code (1byte) | Command (1byte) | Data (0byte) | Checksum (1byte) |
|--------------------|----------------------|----------------------|-----------------|--------------|------------------|
| 0x77               |                      |                      | 0x01            |              |                  |

#### Command response:

| Identifier (1byte) | Frame Length (1byte) | Address Code (1byte) | Command (1byte) | Data (3byte) | Checksum (1byte) |
|--------------------|----------------------|----------------------|-----------------|--------------|------------------|
| 0x77               | 0x07                 |                      | 0x81            | SXXX.YY      |                  |

**Note:** Data represents 3 byte angle value in format of compressed BCD code. S is the sign bit (0 means positive, 1 means negative), XXX is the three digit integer part, YY is the fractional part. The Data of other axis is the same format. For example, 10 26 80 means -26.8 °.

#### 2.2 Set address Command: 77 05 00 0F 01 15

| Identifier (1byte) | Frame Length (1byte) | Address Code (1byte) | Command (1byte) | Data (1byte) | Checksum (1byte) |
|--------------------|----------------------|----------------------|-----------------|--------------|------------------|
| 0x77               |                      |                      | 0x0F            | XX Address   |                  |

#### Command response:

| Identifier (1byte) | Frame Length (1byte) | Address Code (1byte) | Command (1byte) | Data (1byte)                   | Checksum (1byte) |
|--------------------|----------------------|----------------------|-----------------|--------------------------------|------------------|
| 0x77               |                      |                      | 0x8F            | 0x00: success<br>0xFF: failure |                  |



**2.3 Set relative / absolute zero Command: 77 05 00 05 00 0A**

| Identifier (1byte) | Frame Length (1byte) | Address Code (1byte) | Command (1byte) | Data (1byte)                               | Checksum (1byte) |
|--------------------|----------------------|----------------------|-----------------|--|------------------|
| 0x77               |                      |                      | 0x05            | 0x00: absolute zero<br>0x01: relative zero |                  |

**Command response:**

| Identifier (1byte) | Frame Length (1byte) | Address Code (1byte) | Command (1byte) | Data (1byte)                               | Checksum (1byte) |
|--------------------|----------------------|----------------------|-----------------|--|------------------|
| 0x77               |                      |                      | 0x85            | 0x00: absolute zero<br>0xFF: relative zero |                  |

**Note:** absolute zero: Based on the factory-calibrated zero point.  
 relative zero: Reference to the zero after the current installation.

**2.4 Query relative / absolute zero Command: 77 04 00 0D 11**

| Identifier (1byte) | Frame Length (1byte) | Address Code (1byte) | Command (1byte) | Data (0byte) | Checksum (1byte) |
|--------------------|----------------------|----------------------|-----------------|--------------|------------------|
| 0x77               |                      |                      | 0x0D            |              |                  |

**Command response:**

| Identifier (1byte) | Frame Length (1byte) | Address Code (1byte) | Command (1byte) | Data (1byte)                               | Checksum (1byte) |
|--------------------|----------------------|----------------------|-----------------|--|------------------|
| 0x77               |                      |                      | 0x8D            | 0x00: absolute zero<br>0x01: relative zero |                  |

**2.5 Set baud rate Command: 77 05 00 0B 03 13**

| Identifier (1byte) | Frame Length (1byte) | Address Code (1byte) | Command (1byte) | Data (1byte)   | Checksum (1byte) |
|--------------------|----------------------|----------------------|-----------------|--|------------------|
| 0x77               |                      |                      | 0x0B            | 0x00:2400<br>0x01:4800<br>0x02:9600<br>0x03:19200<br>0x04:115200 |                  |

**Command response:**

| Identifier (1byte) | Frame Length (1byte) | Address Code (1byte) | Command (1byte) | Data (1byte)                   | Checksum (1byte) |
|--------------------|----------------------|----------------------|-----------------|--------------------------------|------------------|
| 0x77               |                      |                      | 0x8B            | 0x00: success<br>0xFF: failure |                  |

**Note:** For data, 00: 2400, 01: 4800, 02: 9600, 03: 19200, 04: 115200, Default 02:9600.

**Note:** When the Set baud rate command is executed successfully, the command response will be return in the original baud rate and then communicate with new baud rate.

**2.6 Query address Command: 77 04 00 1F 23**

| Identifier (1byte) | Frame Length (1byte) | Address Code (1byte) | Command (1byte) | Data (1byte) | Checksum (1byte) |
|--------------------|----------------------|----------------------|-----------------|--------------|------------------|
| 0x77               | 0x04                 | 0x00                 | 0x1F            |              |                  |

**Command response:**

| Identifier (1byte) | Frame Length (1byte) | Address Code (1byte) | Command (1byte) | Data (1byte) | Checksum (1byte) |
|--------------------|----------------------|----------------------|-----------------|--------------|------------------|
| 0x77               |                      |                      | 0x1F            |              |                  |

**2.7 Set output mode Command: 77 05 00 0C 00 11**

| Identifier (1byte) | Frame Length (1byte) | Address Code (1byte) | Command (1byte) | Data (1byte)   | Checksum (1byte) |
|--------------------|----------------------|----------------------|-----------------|--|------------------|
| 0x77               |                      |                      | 0x0C            | 0x00: question and answer Mode<br>0x01: 5Hz Data Rate<br>0x02: 10Hz Data Rate<br>0x03: 20Hz Data Rate<br>0x04: 25Hz Data Rate<br>0x05: 50Hz Data Rate<br>0x06: 100Hz Data Rate |                  |

**Note:** The default output mode is 00(when setting 100HZ output frequency).  
 Set baud rate to 115200 in high speed mode.

**Command response:**

| Identifier (1byte) | Frame Length (1byte) | Address Code (1byte) | Command (1byte) | Data (1byte)                   | Checksum (1byte) |
|--------------------|----------------------|----------------------|-----------------|--------------------------------|------------------|
| 0x77               |                      |                      | 0x8C            | 0x00: success<br>0xFF: failure |                  |

**Note:** Set to the response mode, it must receive the read angle command to output the angle. Set to automatic output system, it will automatically output the angle when power is turned on.

**2.8 Save setting Command: 77 04 00 0A 0E**

| Identifier (1byte) | Frame Length (1byte) | Address Code (1byte) | Command (1byte) | Data (1byte) | Checksum (1byte) |
|--------------------|----------------------|----------------------|-----------------|--------------|------------------|
| 0x77               |                      |                      | 0x0A            |              |                  |

**Command response:**

| Identifier (1byte) | Frame Length (1byte) | Address Code (1byte) | Command (1byte) | Data (1byte)                   | Checksum (1byte) |
|--------------------|----------------------|----------------------|-----------------|--------------------------------|------------------|
| 0x77               |                      |                      | 0x8A            | 0x00: success<br>0xFF: failure |                  |

**Note:** If Save setting command is not executed, all setting will be invalid after power off.

## Ordering Information

| Product number | Way of communication | Package condition            |
|----------------|----------------------|------------------------------|
| BWK216-180-232 | RS232                | IP67 Package/Metal Connector |
| BWK216-180-485 | RS485                | IP67 Package/Metal Connector |
| BWK216-180-TTL | TTL                  | IP67 Package/Metal Connector |

## Executive standard

- Enterprise Quality System Standard: ISO9001:2008 Standard (Certificate No.:10114Q16846ROS)
- CE certification (certificate number: 3854210814)
- ROHS (certificate number: SO81426003)
- GB/T 191 SJ 20873-2003 General specifications for tiltmeters and spirit levels
- GBT 18459-2001 sensor main static performance index calculation method
- JF 1059-1999 Evaluation and Expression of Measurement Uncertainty
- GBT 14412-2005 mechanical vibration and shock mechanical installation of accelerometer
- General requirements for GJB 450A-2004 equipment reliability
- Quality control of key parts and important parts of GJB 909A
- GJB 899 Reliability Qualification and Acceptance Test
- GJB 150-3A high temperature test
- GJB 150-4A low temperature test
- GJB 150-8A rain test
- GJB 150-12A dust test
- GJB 150-16A vibration test
- GJB 150-18A impact test
- GJB 150-23A Tilt and Swing Test
- GB/T 17626-3A RF electromagnetic radiation immunity test
- GB/T 17626-5A surge (hit) impulse immunity test
- GB/T 17626-8A power frequency magnetic field immunity test
- GB/T 17626-11A voltage dips, short interruptions and voltage changes immunity

# BWK216 Serials

Digital Single-Axis Inclinator

Wuxi Bewis Sensing Technology LLC

Address: Building 30, No. 58 Xiuxi Road, Binhu District, Wuxi City

Hotline: 400-618-0510

Tel: +86 510 85737158

Email: [sales@bwsensing.com](mailto:sales@bwsensing.com)

Website: [www.bwsensing.com](http://www.bwsensing.com)