



BWK225 Serials

CAN Bus Dual-Axis Inclinometer
Technical Manual



Introduction

Designed by Bewis Sensing Technology LLC, BWK225 is a CAN output low cost dual-axis inclinometer, adopting the latest industrial level MEMS accelerometer. Its measuring range is $\pm 90^\circ$, highest accuracy is 0.2° , working temperature is $-40^\circ\text{C}\sim+85^\circ\text{C}$, the product with a small size and low weight, can meet space-restricted application requirements.

This product converts static gravity field changes into angle changes, It outputs horizontal angle values directly by digital, this product has the advantages of low cost, small temperature drift, simple to use, and strong resistance to external disturbances. It is an ideal option for attitude measurement in photovoltaic power (PV), PTZ control, tower turbines monitoring and other industries.

Features

- Dual-axis inclinometer measurement
- Resolution: 0.02°
- Voltage input: $9\sim 35\text{V}$
- Product size: $L90\text{mm}\times W40.5\text{mm}\times H26\text{mm}$ (customizable)
- Accuracy: 0.2°
- Measuring range: $\pm 90^\circ$
- Output interface: CAN
- IP67 protection

Applications

- Industrial automatic leveling
- Medical devices
- The automatic tracking system of solar angle
- Tower tilt monitoring
- Special valves
- Oil drilling equipment
- Industrial converters
- Crane tilt angle control

Specifications

Electrical Specifications

Parameters	Conditions	Min	Typical	Max	Units
Power supply		9	12	35	V
Operating current	Non-loaded	20	30	40	mA
Operating temperature		-40		+85	°C
Store temperature		-55		+100	°C

Performance Specifications

Measuring range(°)	Conditions	±10	±30	±60	±90
Measuring axis		X-Y	X-Y	X-Y	X-Y
Accuracy(°)	Indoor	0.2	0.2	0.2	0.2
Resolution(°)		0.02	0.02	0.02	0.02
Zero temperature drift(°/°C)	-40 ~ 85°C	±0.01	±0.01	±0.01	±0.01
Cross axis error(°)		0.1	0.1	0.1	0.2
Power on time		≤50ms	≤50ms	≤50ms	≤50ms
The highest frequency output(Hz)		100	100	100	100
MTBF	≥ 30000 hours/time				
Electromagnetic compatibility	according to GBT17626				
Insulation resistance	≥100MΩ				
Shock resistance	2000g,0.5ms,3times/axis				
Weight (g)	210 (package excluded)				

Resolution: The measured minimum change value that the sensor can detect and resolve within the measurement range.

Accuracy: The error between the actual angle and the Root mean square(RMS) of the measured angle of the sensor (≥16 times).

Mechanical Characteristic

Connector	Metal connector (standard cable is 1.5m)
Protection level	IP67
Shell material	Magnesium alloy anodizing
Installation	Four M4 screws

Package size

Product Size: L90*W40.5*H26 (mm)

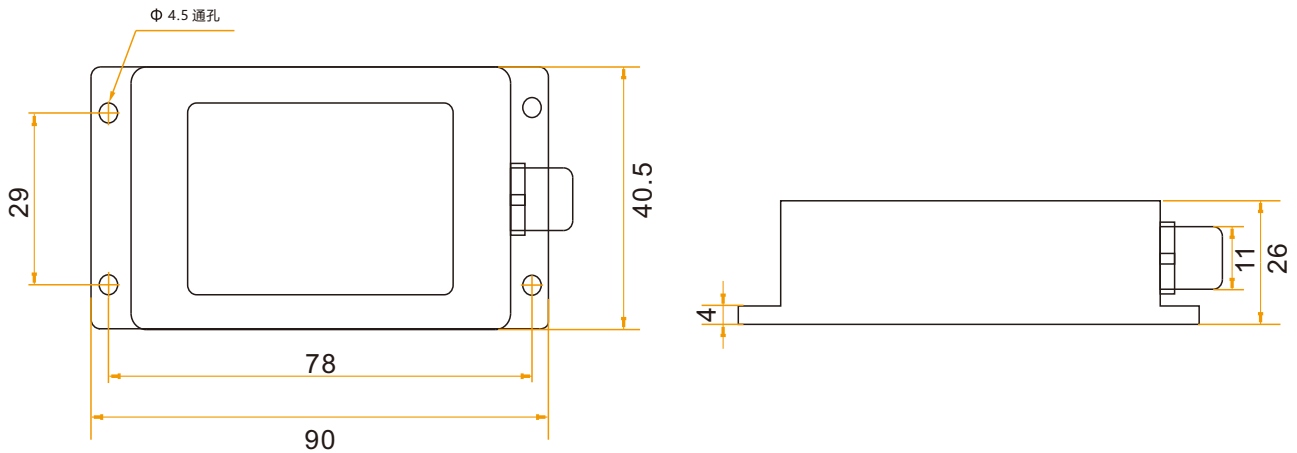

Bare plate product size

Product size: L47*W36*H15 (mm)

Note: ± 1 mm error for length and width dimensions, please refer to actual size.

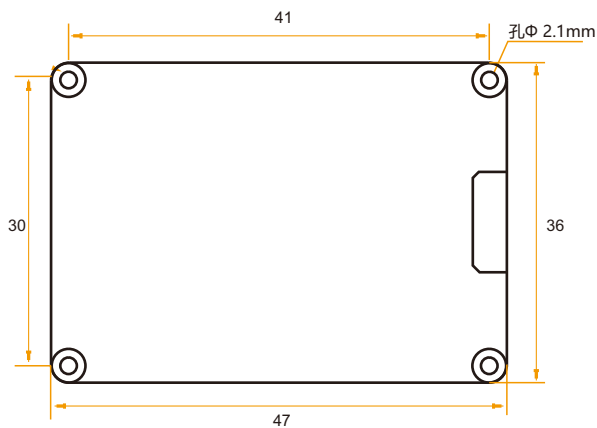

Installation direction

The correct installation method can avoid measurement error. The following points should be made when installing the sensor:

First of all, to ensure that the sensor mounting surface and the measured surface completely close, the measured surface should be as horizontal as possible, can not have the angle shown in Figure A and Figure C, the correct installation is shown in Figure B and Figure D.

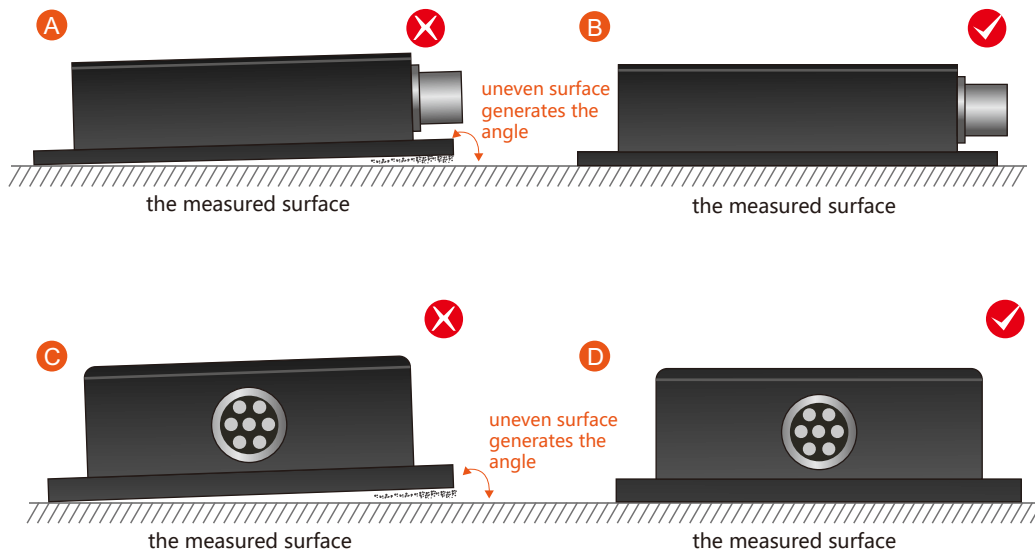

Secondly, the bottom cable of the sensor and the axis of the measured object shouldn't generate the angle shown in E. When installing, the bottom cable of the sensor should be kept parallel or orthogonal to the rotation axis of the measured object. This product can be installed horizontally or vertically (vertical installation requires customization). The correct installation method is shown in Figure F.

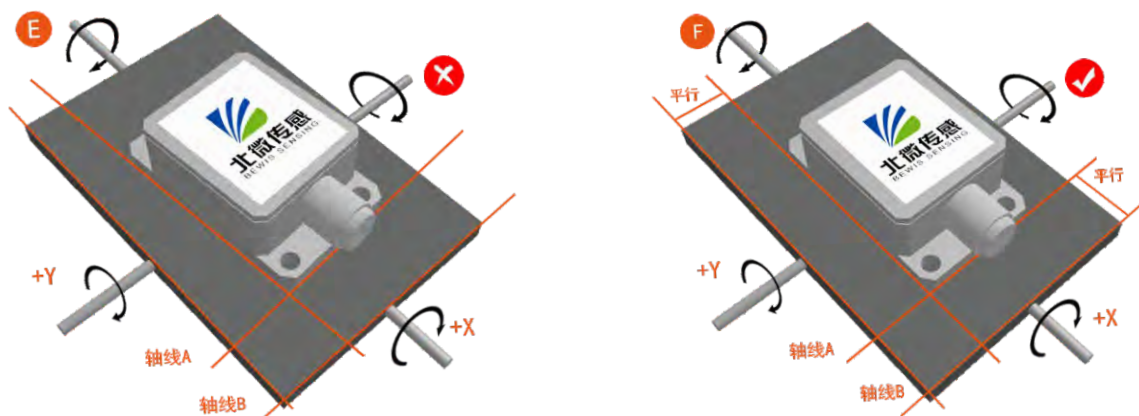

Finally, the installation surface of the sensor must be fixed with the measured surface tightly and smoothly, to avoid measurement error that may be caused by the acceleration and vibration.

Electrical connections

Electrical interfaces

Cable color & Function	RED	BLUE	BLACK	GREEN	YELLOW
	1	2	3	4	5
	VCC DC 9-35V	NC	GND	CAN L	CAN H

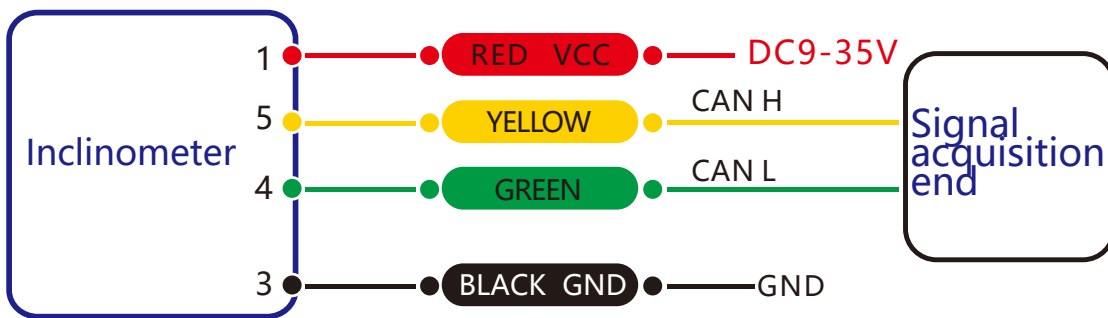

CAN BUS wiring diagram

Protocol

CAN includes 8 bytes. It will add 0 to it when the data bytes is not enough. When the CAN-ID is 600, it is a broadcast address.

Default value: CAN baud rate is 125K, 100HZ automatic output, absolute zero, and node number 05.

1) Modify the nodes

(ID=0x01~0x7F), default ID=0x05

	CAN-ID	The first byte	second	third	fourth	fifth	sixth	seventh	eighth
send	0x600+0x05	0x40	0x10	0x10	0x00	ID	0x00	0x00	0x00
response	0x580+0xID	0x40	0x10	0x10	0x00	ID	0x00	0x00	0x00

Note: If the controller send CAN-ID=0x600+0x05(default), send data:40 10 10 00 10 00 00 00

If the sensor return CAN-ID=0x580+0x10, return data:40 10 10 00 10 00 00 00

Then CAN-ID=0x590(0x580+0x10), in this case, the CAN-ID must be changed to 0x610 (0x600 + 0x10) when sending other names to send successfully. Modify the node number without sending a save command.

2) Set CAN's baud rate

	CAN-ID	The first byte	second	third	fourth	fifth	sixth	seventh	eighth
send	0x600+0x05	0x40	0x20	0x10	0x00	Baud	0x00	0x00	0x00
response									

Note: The fifth byte (Baud) means 0x01, 0x02, 0x03, 0x04.

- 0x01 means to set 500k bps as the baud rate.
- 0x02 means to set 250k bps as the baud rate.
- 0x03 means to set 125k bps as the baud rate.
- 0x04 means to set 100k bps as the baud rate.

The default baud rate is 125k bps. Once you revise the baud rate and want to make a success revise, the sensor need to be re-powered.

3) Set relative / absolute zero

	CAN-ID	The first byte	second	third	fourth	fifth	sixth	seventh	eighth
send	0x600+0x05	0x40	0x05	0x10	0x00	Type	0x00	0x00	0x00
response	0x580+0x05	0x40	0x05	0x10	0x00	0x00	0x00	0x00	0x00

Note: the fifth byte means 0x00 and 0x01.

0x00 indicates the setting is an absolute zero, 0x01 indicates a relative zero.

After setting the zero point, you need to enter the save command to set it successfully. (Default is absolute zero)

Absolute zero: Based on the factory-calibrated zero point.

Relative zero: Reference to the zero after the current installation.

4) Query relative/ absolute zero

	CAN-ID	The first byte	second	third	fourth	fifth	sixth	seventh	eighth
send	0x600+0x05	0x40	0x0d	0x10	0x00	0x00	0x00	0x00	0x00
response	0x580+0x05	0x40	0x0d	0x10	0x00	Type	0x00	0x00	0x00

Note: The fifth byte means 0x00 and 0x01. 0x00 indicates an absolute zero and 0x01 indicates a relative zero.

5) Save the setting

	CAN-ID	The first byte	second	third	fourth	fifth	sixth	seventh	eighth
send	0x600+0x05	0x40	0x0a	0x10	0x00	0x00	0x00	0x00	0x00
response	0x580+0x05	0x40	0x0a	0x10	0x00	0x00	0x00	0x00	0x00

Note: For some parameter, revised parameter doesn't work until you send the saving command.

6) Read angle of X-axis and Y-axis

	CAN-ID	The first byte	second	third	fourth	fifth	sixth	seventh	eighth
send	0x600+0x05	0x40	0x04	0x10	0x00	0x00	0x00	0x00	0x00
response	0x580+0x05	0xSX	0xXX	0xYY	0xSX	0xXX	0xYY	0x00	0x00

Note: Reading angle command can be effective under the response mode.

The first, second and third bytes are the X axis angle; the fourth, fifth and sixth bytes are the Y axis angle; Among them, S is a sign bit (0 represents a positive value, 1 represents a negative value), XXX represents a 3-bit integer bit of the angle, and YY represents an angle of 2 is a decimal place.

If the return date is 585 00 12 34 50 10 12 34 00 00, the angle of X-axis is +12.34°, the Y-axis is -12.34°.

7) Set the output mode

	CAN-ID	The first byte	second	third	fourth	fifth	sixth	seventh	eighth
send	0x600+0x05	0x40	0x0c	0x10	0x00	mode	0x00	0x00	0x00
response	0x580+0x05	0x40	0x0c	0x10	0x00	mode	0x00	0x00	0x00

Note: The fifth byte mode is 0x00: answer mode,

- 0x01: 5Hz Data Rate,
- 0x02: 10Hz Data Rate
- 0x03: 20Hz Data Rate,
- 0x04: 25Hz Data Rate,
- 0x05: 50Hz Data Rate,
- 0x06: 100Hz Data Rate (default)

5Hz Data Rate means that 5 sets of angle data are automatically output every second, other modes are similar to this.

8) Inclinometer sensor automatically outputs the angle

When the sensor is set to automatic mode output, the sensor automatically outputs the angle according to a certain frequency after the sensor is powered on. The default is automatic 100Hz mode. Set to answer mode, the sensor must receive the read angle command, the sensor output angle

	CAN-ID	The first byte	second	third	fourth	fifth	sixth	seventh	eighth
send									
response	0x580+0x05	0xSX	0xXX	0xYY	0xSX	0xXX	0xYY	0x00	0x00

Note: The resolution of the output angle format is the same as that of the response mode to read the X and Y aixe.

9) Set the type of CAN-ID

	CAN-ID	The first byte	second	third	fourth	fifth	sixth	seventh	eighth
send	0x600+0x05	0x40	0x70	0x10	0x00	XX	0x00	0x00	0x00
response									

Note: XX means 00 and 01. 00 means the standard ID type (11 bits) and 01 means extended ID type (27 bits).

The default type is the standard one.

Before setting the standard ID and extension ID, you need to send this command to switch to the corresponding type.

Set the CAN-ID type, standard CAN-ID address, extended CAN-ID address do not need to send a save command, after setting is complete and then re-power can be set to the result.

10) Set the standard address of CAN-ID

	CAN-ID	The first byte	second	third	fourth	fifth	sixth	seventh	eighth
send	0x600+0x05	0x40	0x71	0x10	0x00	XH	XL	0x00	0x00
response	0xXHXL+0x05								

Note: The default standard CAN-ID is 0x580+05 and the maximum is not more than 7FF. Here we revise '580' in '0x580+05', 05 can be modified through the front nodes. After revise, the CAN-ID will become 0xXHXL+0x05 when re-powered on.

For example, send the data: 605 40 71 10 00 01 23 00 00, the CAN-ID will become 123+5=128 when it is repowered on.

11) Set the extended address of CAN-ID

We need to divide the address into two when setting the address of extended CAN-ID. First send high 16 address, then send the low 16 address. The CAN-ID address will change into new one (here the CAN-ID address we receive do not need to add the nodes) after being re-powered on. The maximum can not be more than 0x1FFFFFFF. The default is 0x18fa0216.

I Set high 16 extended address of CAN-ID

	CAN-ID	The first byte	second	third	fourth	fifth	sixth	seventh	eighth
send	0x600+0x05	0x40	0x72	0x10	0x00	XH	XL	0x00	0x00
response									

Note: the high 16 address can not surpass 0X1FFF.

II Set low 16 extended address of CAN-ID

	CAN-ID	The first byte	second	third	fourth	fifth	sixth	seventh	eighth
send	0x600+0x05	0x40	0x73	0x10	0x00	XH	XL	0x00	0x00
response									

Note: Low 16 address can not surpass FFFF.

For example, send the data respectively as follows, 605 40 72 10 00 01 23 00 00 and 605 40 73 10 00 45 67 00 00. CAN-ID will change into 01234567 after being re-powered on.

Ordering Information

Product number	Way of communication	Package condition
BWK225-90-CAN	CAN	IP67 Package/Metal Connector

Executive standard

- Enterprise Quality System Standard: ISO9001:2008 Standard (Certificate No.: 10114Q16846ROS)
- CE certification (certificate number: 3854210814)
- ROHS (certificate number: SO81426003)
- GB/T 191 SJ 20873-2003 General specifications for tiltmeters and spirit levels
- GBT 18459-2001 sensor main static performance index calculation method
- JJF 1059-1999 Evaluation and Expression of Measurement Uncertainty
- GBT 14412-2005 mechanical vibration and shock mechanical installation of accelerometer
- General requirements for GJB 450A-2004 equipment reliability
- Quality control of key parts and important parts of GJB 909A
- GJB 899 Reliability Qualification and Acceptance Test
- GJB 150-3A high temperature test
- GJB 150-4A low temperature test
- GJB 150-8A rain test
- GJB 150-12A dust test
- GJB 150-16A vibration test
- GJB 150-18A impact test
- GJB 150-23A Tilt and Swing Test
- GB/T 17626-3A RF electromagnetic radiation immunity test
- GB/T 17626-5A surge (hit) impulse immunity test
- GB/T 17626-8A power frequency magnetic field immunity test
- GB/T 17626-11A voltage dips, short interruptions and voltage changes immunity

BWK225 Serials

CAN Bus Dual-Axis Inclinator

Wuxi Bewis Sensing Technology LLC

Address: Building 30, No. 58 Xiuxi Road, Binhu District, Wuxi City

Hotline: 400-618-0510

Tel: +86 510 85737158

Email: sales@bwsensing.com

Website: www.bwsensing.com