

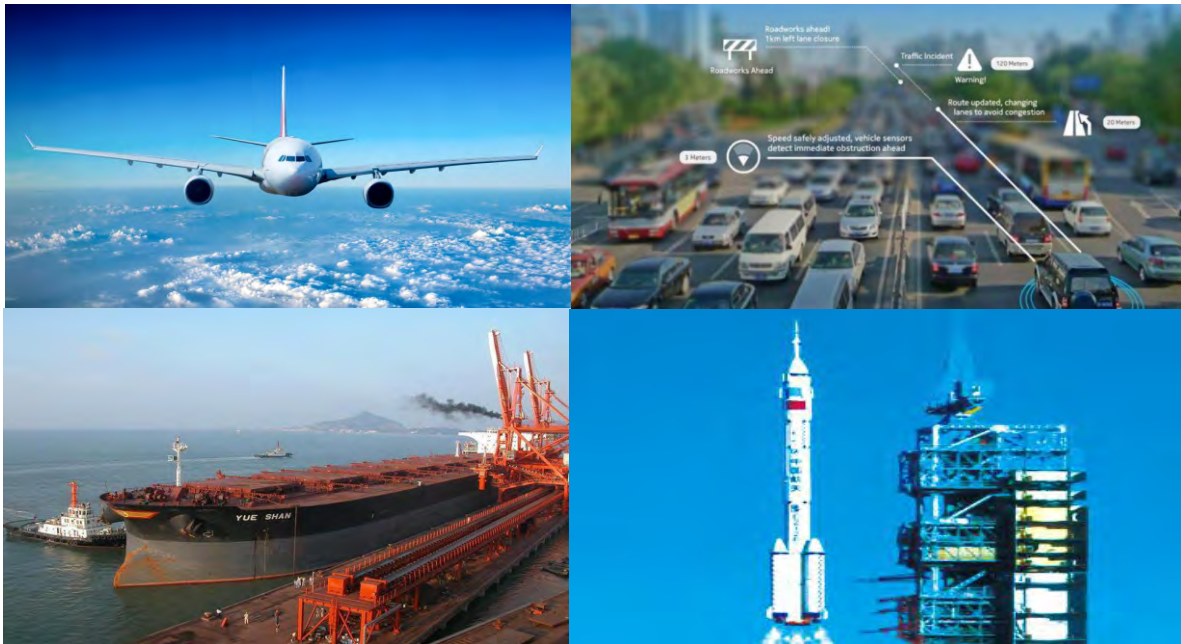

GI530 Serials

High Precision FOG Integrated
Navigation System

Technical Manual



Introduction

BW-GI530 is a high-performance high-precision fiber micro-inertial navigation system developed by Bewis for aviation mapping, unmanned aerial vehicles, sea-based and roadbed fields. Built-in three-axis gyroscope (single-axis fiber, dual-axis MEMS) The three-axis accelerometer includes a BD/GPS/GLONAS three-mode receiver that measures the speed, position, and attitude of the carrier.

The BW-GI530 is equipped with a new integrated navigation sensor fusion algorithm engine. It is optimized for multipath interference and can meet the needs of long-term, high-precision and high-reliability navigation applications in urban and outdoor complex environments. The product supports a variety of sensors such as GNSS/odometer/DVL/barometric altimeter and has excellent scalability. It combines inertial measurement with satellite navigation and odometer information through multi-sensor data fusion technology. These can greatly improve the system's geographical adaptability.

BW-GI530 integrated navigation system adopts coupling technology. It combines high-precision, professional-grade, multi-channel, dual-antenna single-frequency carrier phase and pseudo-range GPS receivers with high-precision fiber inertial measurement units. It has the characteristics of small size, light weight and high performance.

Applications

- Antenna stabilization platform, drone flight control
- Navigation and control of AGV
- Attitude measurement and orientation reference

Specifications

Performance Specifications

Attitude accuracy	(2m baseline)	0.1 deg
	Satellite signal loss	0.09deg /5min; 0.9 deg /1h
	Rolling attitude accuracy	≤0.5 deg
	Pitch attitude accuracy	≤0.5 deg
Combined external GPS	Speed accuracy	0.1m/s
	Single point positioning accuracy	DGPS accuracy 0.5m /RTK accuracy 2cm
	Directional accuracy	0.1deg, (2m baseline)
Measuring range	Azimuth	±180 deg
	Roll angle	±90 deg
	Pitch angle	±90 deg
	Angular velocity	±300 deg/s
	Acceleration	±4 g
Interface characteristics	Power supply	9~36 VDC, ≤8 W @ 24VDC
	Electrical interface	RS422
	Data update rate	100 Hz @ 115,200 baud rate
Environment	Operating temperature	-40°C ~ +60°C
	Storage temperature	-55°C ~ +85°C
Physical characteristics	Size	Φ89mm×118 mm(designable)
	Weight	≤600 g
	Connector	Y11P-1210ZK10

Product Size

Product Size: $\Phi 89 \times 118$ (mm)

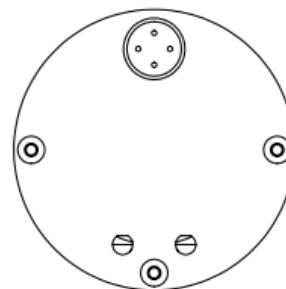
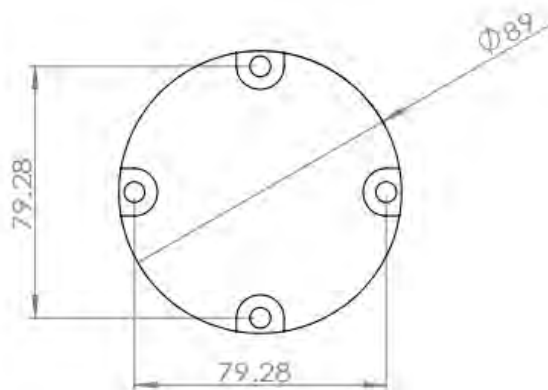
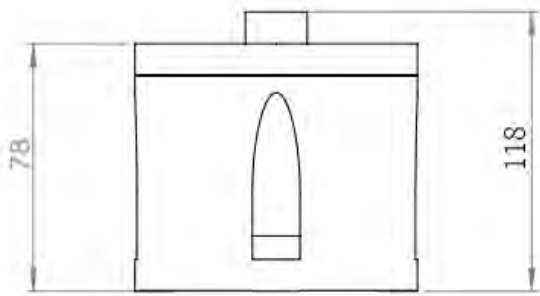

Note: Unfilled dimensional tolerances are performed in accordance with GB/T1804-2000 Class C.

Product installation

The correct installation method can avoid measurement error. The inertial measurement unit produces an absolutely smooth surface by grinding on the underside and measuring surface for installation. The following points should be made when installing the sensor:

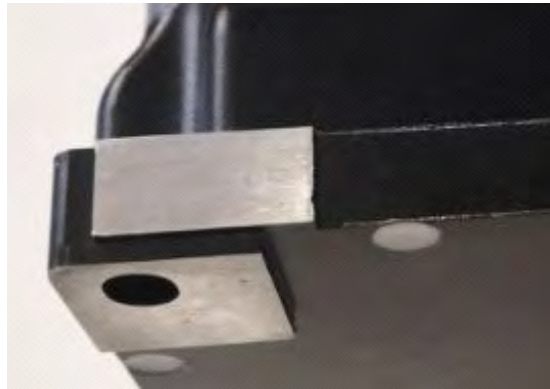

First of all, to ensure that the sensor mounting surface and the measured surface completely close, the measured surface should be as horizontal as possible, so that we can reduce installation error. Secondly, when the product is installed, the bottom surface of the IMU and the body should be coincident, and it is gently pushed to make the measurement surface of the IMU coincide with that of the machine body, so that both surfaces are tightly attached, and there is no angle in Fig.A and Fig.C. The correct installation is shown in Fig.B and Fig.D.

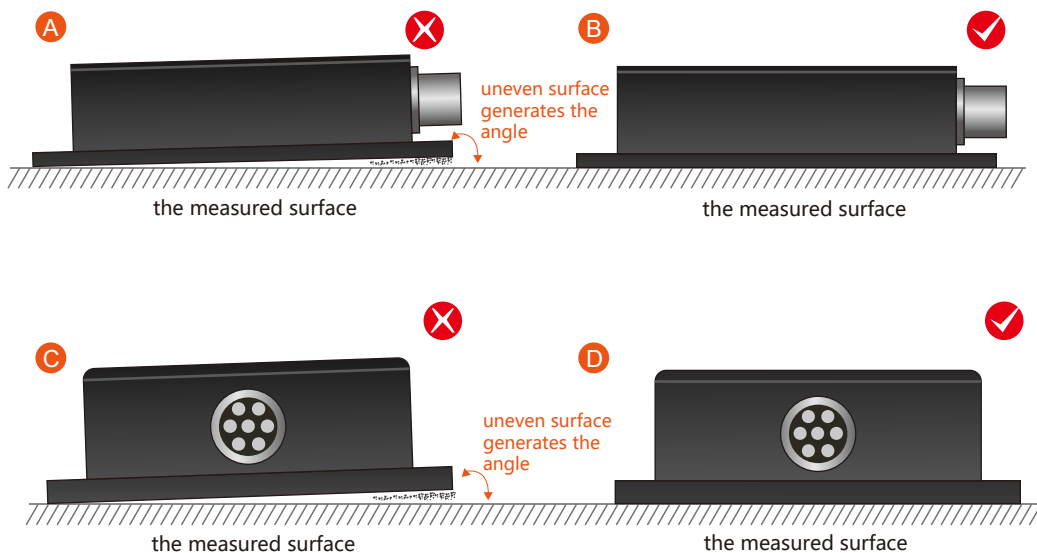

Finally, after the product is tightly attached, screws should be used to fix the IMU to ensure tight fixation, smooth conduct and stable rotation. Measurement errors caused by acceleration and vibration should be voided. Bear in mind that the screw only plays a fixed role and does not have a positioning function. The screw hole of the IMU is processed into an elliptical shape for easy adjustment.

Electrical connections

Data cable RS422 interface definition, DB9 female:

DB9 connector pin	Interface definition	Remarks
1	R+	Receive +
2	R-	Receive -
3	T+	Transmit +
4	T-	Transmit -

Debugging software

Software usage steps:

- ① Ensure that the inertial navigation is absolutely static,correctly connect the serial port hardware of the integrated navigation,and connect the power supply.
- ② Select the computer serial port and baud rate and click to connect to the serial port.
- ③ Enter the correct geographic latitude,click Inertial Navigation Start→Command Input,the working status on the screen shows static alignment,and the working state becomes INS navigation.At this time,the inertial navigation enters the working state and can be used.



Protocol

After the system is powered on, the normal operating time is 20Hz frequency, RS422 communication 115200bps, n, 8, 1 broadcast broadcast navigation data, 48 bytes per frame data as shown in the following table:

Navigation data			
Byte number	Content	Data type	Byte count
1-2	Frameheader: 0X5A0XA5	Byte	2
3	Workingstatus:0- Monitoring status,1-Staticalignment,2-INS navigation	Byte	1
4-5	Inertialpitchangle([-90,90] degrees) in units of 0.01 degrees	Short int (low byte first, high byte last)	2
6-7	Inertialguiderollangle ([-180,180]degrees),unit 0.01 degree		2
8-9	Inertialazimuth([-180,180] degrees),northto eastis -, north to west is +, unitis 0.01degrees		2
10-11	nertialX-axisangularvelocity Wx(degree/s) in units of 0.01 deg/s		2
12-13	nertial Y-axis angular velocity Wy(degree/s) in units of 0.01 deg/s		2
14-15	nertial Z-axis angular velocity Wx(degree/s) in units of 0.01 deg/s		2
16-17	Inertial X-axis acceleration Ax(m/s/s), unit0.01m/s/s		2
18-19	Inertial Y-axisaccelerationAy (m/s/s), unit 0.01m/s/s		2
20-21	Inertial Z-axis acceleration Az (m/s/s), unit0.01m/s/s		2
22-23	Speed after GPS satellite positioning, unit0.1m/sec		2
24-25	GPS trackangle([-180,180] degrees),north to the east is -, north to west is +, the unit is 0.1 degrees		2
26-27	GPS satellite number		2
28-29	GPS altitude, unit 0.1 m		2
30-33	Latitude after GPS satellite positioning, unit degree		Float(low byte first, high byte after), value range [-90,90] degrees, the north latitude is + and the south latitude is -.
34-37	Longitude after GPS satellite positioning, unit degree	Float (low byte first, high byte after), value range[-180,180] degrees, east longitude is +, west	4

Executive standard

- Enterprise Quality System Standard: ISO9001:2008 Standard(Certificate No.:10114Q16846ROS)
- CE certification (certificate number: 3854210814)
- ROHS (certificate number: SO81426003)
- GJB 2426A-2004 Fiber Optic Gyro Test Method
- GBT 18459-2001 sensor main static performance index calculation method
- JF 1059-1999 Evaluation and Expression of Measurement Uncertainty
- GBT 14412-2005 mechanical vibration and shock mechanical installation of accelerometer
- General requirements for GJB 450A-2004 equipment reliability
- Quality control of key parts and important parts of GJB 909A
- GJB 899 Reliability Qualification and Acceptance Test
- GJB 150-3A high temperature test
- GJB 150-4A low temperature test
- GJB 150-8A rain test
- GJB 150-12A dust test
- GJB 150-16A vibration test
- GJB 150-18A impact test
- GJB 150-23A Tilt and Swing Test
- GB/T 17626-3A RF electromagnetic radiation immunity test
- GB/T 17626-5A surge (hit) impulse immunity test
- GB/T 17626-8A power frequency magnetic field immunity test
- GB/T 17626-11A voltage dips, short interruptions and voltage changes immunity
- GB/T 2423.22-2012 Environmental testing Part 2:test method Test N:temperature change (IEC 60068-2-14:2009,IDT)
- GB/T 10125-2012Artificial atmosphere corrosion test Salt spray test (ISO 9227:2006,IDT)

GI530

High Precision FOG Integrated Navigation System

Wuxi Bewis Sensing Technology LLC

Address: Building 30, No. 58 Xiuxi Road, Binhu District, Wuxi City

Hotline: 400-618-0510

Tel: +86 510 85737178-801

Email: sales@bwsensing.com

Website: www.bwsensing.com