



SEC345 Serials

Inclination Compensation
3D Electronic Compass

Technical Manual



Introduction

SEC345 is a cost-effective 3D electronic compass developed by Bewis Sensing Technology LLC. The product adopts the patented hard iron and soft iron calibration algorithm of Beiwei Sensing Technology LLC, which can provide high-precision heading information when its inclination reaches 40°. It has the advantages of small size and low power consumption, and is suitable for sensitive measurement systems with small size and high precision. The SEC345 integrates a three-axis magnetic sensor that compensates for the tilt angle with a three-axis accelerometer when the heading is solved in real time by the central processor, providing accurate heading data in very harsh environments. The SEC345 supports RS232, RS485 and TTL level output interfaces. The output baud rate is 2400-115200, and the output angle is 0°~360°. There are two types of hexadecimal and Modbus protocols. It can be adapted to different application scenarios and can integrate the electronic compass function into various systems very conveniently and quickly.

Features

- Accuracy: 1° (RMS)
- Operating temperature: -40 °C ~ +85 °C
- Small size: L55 x W37x H24(mm)
- Supply voltage: 5V
- Hard magnetic, soft magnetic and tilt compensation
- Resolution: 0.1°
- Rolling pitch accuracy: 0.1°
- RS232/RS485/TTL interface optional

Applications

- Satellite tracking
- Petroleum geological exploration
- Optical range finder
- GPS-assisted navigation
- Individual combat equipment
- Ocean test
- Underwater navigation
- Mechanical control

Specifications

Electrical Specifications

Power supply	+5V DC
Operating current	30mA (Max40mA)
Operating temperature	-40~85°C
Store temperature	-55~100°C

Performance Specifications

Compass heading parameter	Heading accuracy	1° (RMS , Pitch <85°)
	Resolution	0.1°
	Repeatability	0.3°
Compass tilt parameter	Pitch accuracy	0.1°
	Rolling accuracy	0.1°
	Dip resolution	0.01°
	Tilt range	±40°
Calibration	Hard magnetic calibration	Yes
	Soft magnetic calibration	Yes
	Tilt calibration	Yes
Physical specifications	Size	L55 x W37 x H24 (mm)
	Weight	130g
	Output form	RS232/485/TTL Optional
Interface specifications	Start delay	<3s
	Frequency response	50Hz
	RS-232Communication rate	2400-115200 Baud rate
Environment	Anti-vibration performance	2000g

Resolution: The measured minimum change value that the sensor can detect and resolve within the measurement range.

Accuracy: The error between the actual angle and the Root mean square(RMS) of the measured angle of the sensor (≥ 16 times).

Mechanical Characteristic

Connector	Metal connector (standard cable is 1.5m)
Protection level	IP67
Shell material	Magnesium alloy anodizing
Installation	Three M4 screws

Package size

Product Size: L55*W37*H24(mm)

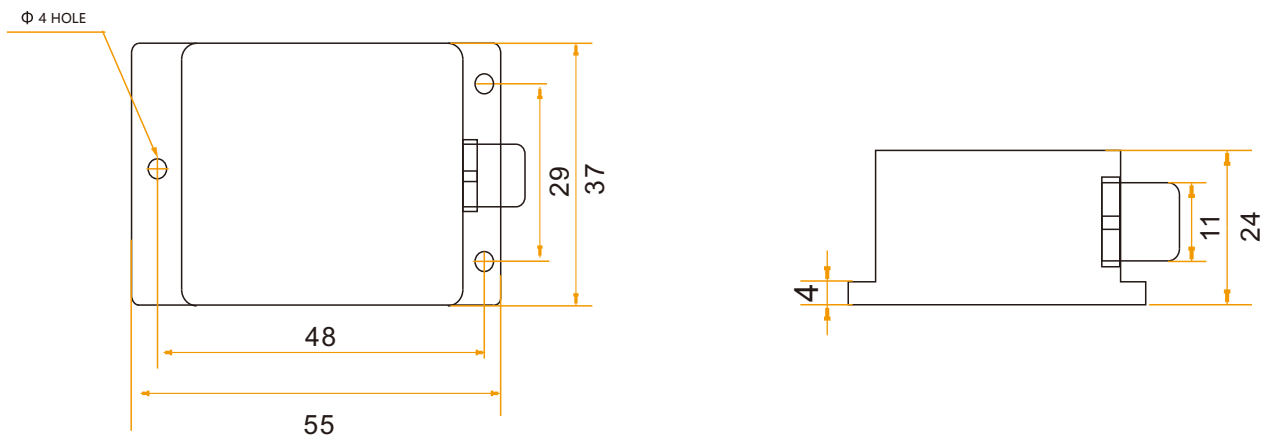

Bare plate product size

Product Size: L33*W27*H6(mm) ± 1 mm error for length and width dimensions, please refer to actual size

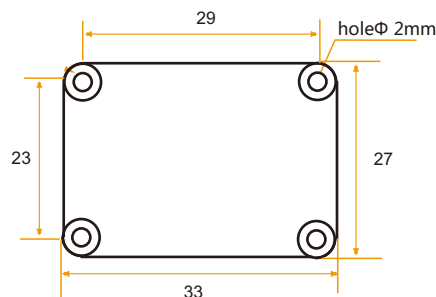

Measurement & Installation

The main sensitive components of the SEC345 sensor are magnetometers and accelerometers. The compass uses a magnetometer to sense the geomagnetic field to calculate the direction of the sensor. The accelerometer is used to measure the angle between the compass and the gravity, and provides the tilt compensation when the compass calculates the azimuth. The earth's magnetic field is easily interfered by the external magnetic field. Users should pay attention to the surrounding magnetic field during installation to ensure that the sensor is exposed to the earth's magnetic field and avoid using it near ferromagnetic materials and changing magnetic fields, Such as engines, iron plates, iron bolts and nuts, wires, motors, speakers, antennas, etc. It is important to strictly avoid magnets, motors and other strong magnetic substances within 10cm of the compass, which may cause the measurement accuracy of the compass to irreversibly decrease. We strongly recommend magnetic field calibration after installation and every time the magnetic field environment changes. After the calibration in accordance with the manual, the firmware and program in the SEC345 can effectively eliminate the interference of the magnetic field. As long as the position of the compass and the surrounding magnetic field environment have not changed, it is no longer necessary to compensate the sensor.

Tests have shown that if the user performs the calibration operation according to the requirements of the user manual so that the compass can meet the above requirements during installation and correctly calibrate the sensor, the heading accuracy of the sensor will be less than 2 degrees (RMS). The recommended test method is to mount the SEC345 sensor horizontally on a non-magnetic material away from interference for heading angle measurement. Avoid extra magnetic field interference during measurement.

Calibration

The electronic compass has been calibrated at the factory. In places where the influence of the magnetic field environment is small, it is not necessary to perform environmental calibration and can be used directly. During actual use, it is recommended to perform calibration.

Azimuth calibration step:

Method 1 - Plane calibration:

1. Connect the product to the system and place the product in a horizontal state;
2. Open the serial port debugging assistant and send 77 04 00 11 15;
3. Rotate the product in the horizontal plane (with the pitch and roll angles within $\pm 5^\circ$) around the z-axis (z-axis is vertical) and rotate 2-3 turns. The rotation process is as slow as possible and rotates at a constant speed. The time of one rotation is controlled between 10 seconds and 15 seconds;
4. Rotating the compass around the X-axis or the Y-axis, the rotation process is as slow as possible and rotates at a constant speed, rotating 2-3 turns around each axis, and the time of one rotation is about 15 seconds;
5. Complete calibration, send 77 04 00 12 16 to save calibration.

Method 2 - Multi-face calibration:

1. Fix the electronic compass in the use environment, and try not to carry magnetic items such as keys and mobile phones during calibration;
2. Place the compass in a horizontal state (within $\pm 5^\circ$);
3. Send the following calibration command in hexadecimal format: 77 04 00 08 0C, return value 77 05 00 88 00 8D;
4. The product is placed horizontally, face up (pitch and roll are within $\pm 5^\circ$), rotate one revolution at a constant speed approximately and use for more than 10 seconds.
5. The product is placed horizontally, with the mounting surface facing up (pitch and roll are within $\pm 5^\circ$), rotate one revolution at a constant speed approximately and use for more than 10 seconds.

6. The product is placed in a vertical state, the smooth side of the casing is facing downward (the pitch and the roll are both within $\pm 5^\circ$), rotate one revolution at a constant speed approximately and use for more than 10 seconds.
7. The product is placed in a vertical state, and the other smooth side of the casing faces downward (the pitch and the roll are both within $\pm 5^\circ$), rotate one revolution at a constant speed approximately and use for more than 10 seconds.
Where step 4.5.6.7 can be exchanged;
8. After the four faces have been rotated, send the hexadecimal command 77 04 00 09 0D to save the calibration and return to 77 05 00 89 XX YY. (XX represents the calibration error coefficient, the smaller the value, the better, less than 1 is ideal, FF indicates calibration failure, and YY is the checksum of the command);
9. Calibration completed

Electrical connections

Electrical interfaces

Cable color & function	RED	BLUE	BLACK	GREEN	YELLOW
	1	2	3	4	5
	VCC DC 5V	NC	GND	RXD (B、 D-)	TXD (A、 D+)

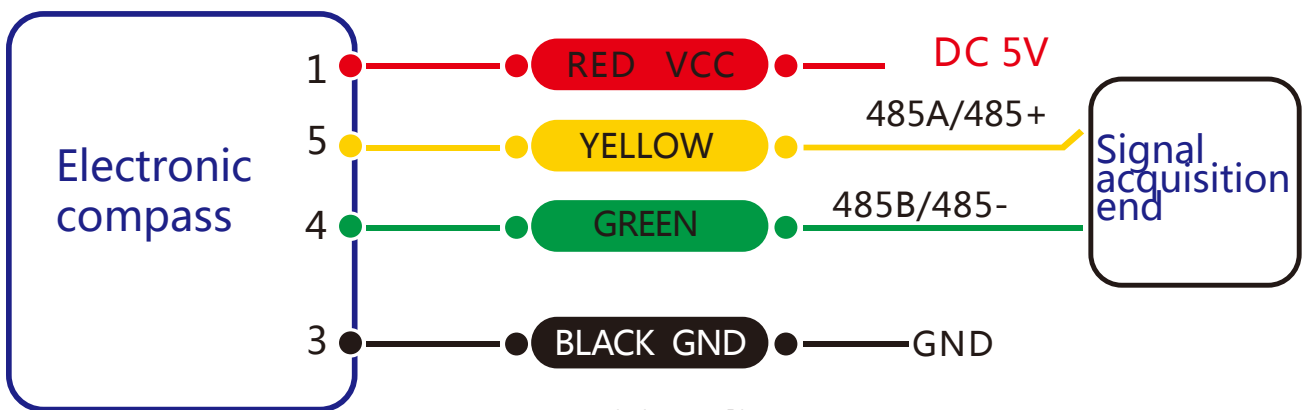

RS 485 wiring diagram

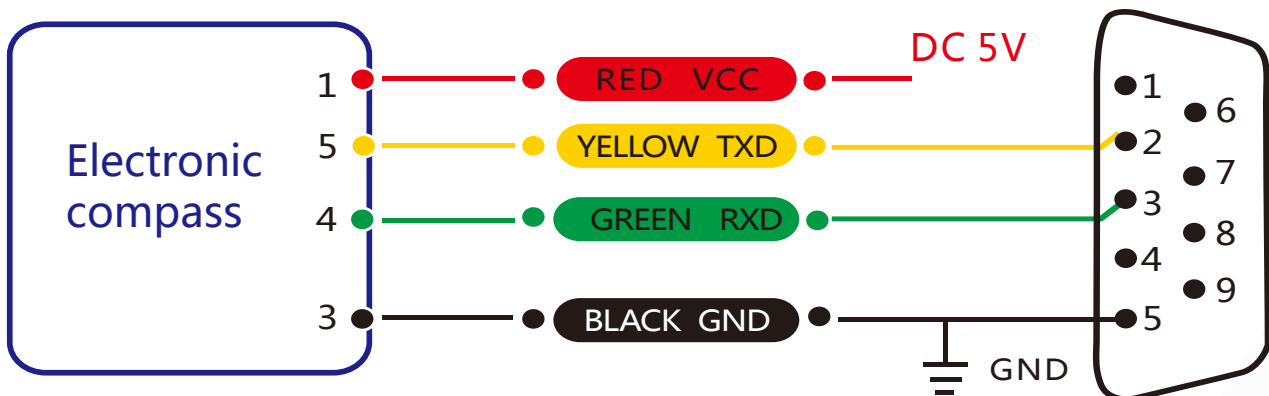

RS 232 wiring diagram

Protocol

1 Data Frame Format: (8 data bits, 1 stop bit, No parity check, default baud rate 9600)

Identifier (1byte)	Frame Length (1byte)	Address Code (1byte)	Command (1byte)	Data (0byte)	Checksum (1byte)
0x77					

Data Format: Hexadecimal

Identifier: Fixed to 77

Frame Length: Length from Frame Length to Checksum (included)

Address Code: Address of acquiring module, default 0x00

Data: Content and length variable according to Command

Checksum: Sum of Frame Length, Address Code, Command and Data. (Please pay attention that when the command or data changes, the checksum will change.)

2 Command Format:

2.1 Read PITCH angle Command : 77 04 00 01 05

Identifier (1byte)	Frame Length (1byte)	Address Code (1byte)	Command (1byte)	Data (0byte)	Checksum (1byte)
0x77	0x04		0x01		0x05

Command response:

Identifier (1byte)	Frame Length (1byte)	Address Code (1byte)	Command (1byte)	Data (3byte)	Checksum (1byte)
0x77	0x07		0x81	SXXX.YY	

Note: Data represents 4 byte angle value in format of compressed BCD code. S is the sign bit (0 means positive, 1 means negative), XXX is the three digit integer part, YY is the fractional part. The Data of other axis is the same format. For example, 10 26 87 means -026.87 °.

2.2 Read ROLL angle Command: 77 04 00 02 06

Identifier (1byte)	Frame Length (1byte)	Address Code (1byte)	Command (1byte)	Data (0byte)	Checksum (1byte)
0x77	0x04		0x02		0x06

Command response:

Identifier (1byte)	Frame Length (1byte)	Address Code (1byte)	Command (1byte)	Data (3byte)	Checksum (1byte)
0x77	0x07		0x82	SXXX.YY	

2.3 Read Heading azimuth angle Command: 77 04 00 03 07

Identifier (1byte)	Frame Length (1byte)	Address Code (1byte)	Command (1byte)	Data (0byte)	Checksum (1byte)
0x77	0x04		0x03		

Command response:

Identifier (1byte)	Frame Length (1byte)	Address Code (1byte)	Command (1byte)	Data (3byte)	Checksum (1byte)
0x77	0x07		0x83	SXXX.YY	

2.4 Read PITCH,ROLL,HEADING axis angle Command: 77 04 00 04 08

Identifier (1byte)	Frame Length (1byte)	Address Code (1byte)	Command (1byte)	Data (0byte)	Checksum (1byte)
0x77	0x04		0x04		0x06

Command response:

Identifier (1byte)	Frame Length (1byte)	Address Code (1byte)	Command (1byte)	Data (9byte)	Checksum (1byte)
0x77	0x07		0x84	SXXX.YY	

Note: The data field contains 9 bytes of Pitch, Roll and Heading angle values, which are compressed BCD codes, each of which is a group of three bytes. For example, the return command is 77 0D 00. 84 10 26 80 00 33 65 03 13 71 66, where Pitch is 10 26 80, Roll is 00 33 65, Heading is 03 13 71. For the three bytes of the return value for each angle, the format is SX XX YY, S is the sign bit (0 positive, 1 negative) XXX is a three-digit integer value, and YY is a decimal value. The corresponding three angle readings for this example are: -26.8°, 33.65°, 313.71°.

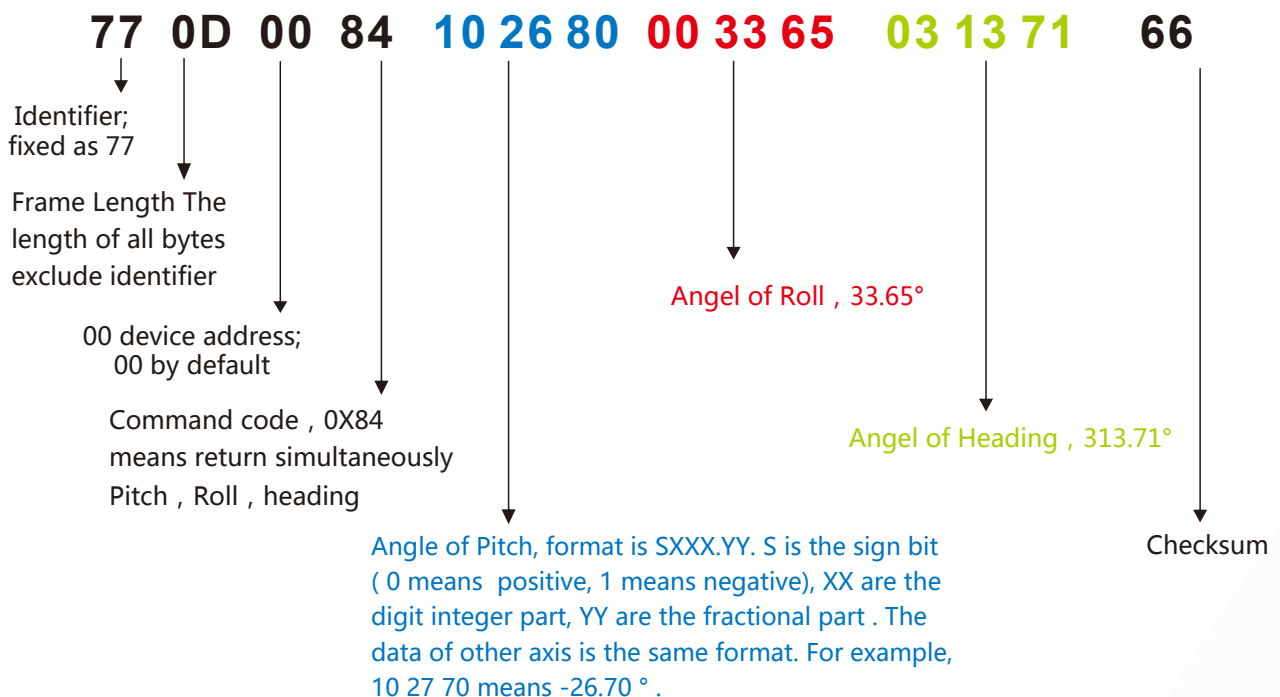

2.5 Set baud rate Command: 77 05 00 0B 02 12

Identifier (1byte)	Frame Length (1byte)	Address Code (1byte)	Command (1byte)	Data (1byte)	Checksum (1byte)
0x77	0x05		0x0B		

Command response:

Identifier (1byte)	Frame Length (1byte)	Address Code (1byte)	Command (1byte)	Data (1byte)	Checksum (1byte)
0x77	0x05			0x00: success 0xFF: failure	

Note: 00:2400,01:4800,02:9600,03:19200,04:115200,05:38400,6:57600. If the baud rate is set to 19200, the command is 77 05 00 0B 03 13, where 13 = 05+ 00+ 0B+ 03, and so on when setting other baud rates.

Note: After setting the baud rate, the device will return the response command at the original baud rate. After that, the baud rate setting will take effect and the host computer needs to make the corresponding baud rate change to re-communicate with the device.

2.6 Set the magnetic declination Command: 77 06 00 06 02 08 16

Identifier (1byte)	Frame Length (1byte)	Address Code (1byte)	Command (1byte)	Data (2byte)	Checksum (1byte)
0x77	0x06		0x06	SXXX.YY	0x06

Command response:

Identifier (1byte)	Frame Length (1byte)	Address Code (1byte)	Command (1byte)	Data (1byte)	Checksum (1byte)
0x77	0x05		0x86	0x00: success 0xFF: failure	

Note: S indicates a symbol, 0 is positive 1 is negative, XX is a two-digit integer, and Y is 1 decimal. For example, 02 08 is +20.8°. The checksum of the command is 16 (hex).16 = 06+00+06+02+08. If the declination is set to -3.2°, the command is 77 06 00 06 10 32 4E, where 4E = 06+00+06+10+32. Other magnetic declinations are analogous.

2.7 Read magnetic declination Command: 77 04 00 07 0B

Identifier (1byte)	Frame Length (1byte)	Address Code (1byte)	Command (1byte)	Data (0byte)	Checksum (1byte)
0x77	0x04		0x07		

Command response:

Identifier (1byte)	Frame Length (1byte)	Address Code (1byte)	Command (1byte)	Data (2byte)	Checksum (1byte)
0x77	0x06		0x87	SXXY	

2.8 Set address Command: 77 05 00 0F 01 15

Identifier (1byte)	Frame Length (1byte)	Address Code (1byte)	Command (1byte)	Data (1byte)	Checksum (1byte)
0x77	0x05		0x0F	XX Address	

Command response:

Identifier (1byte)	Frame Length (1byte)	Address Code (1byte)	Command (1byte)	Data (1byte)	Checksum (1byte)
0x77	0x05		0x8F	0x00: success 0xFF: failure	

2.9 Query address Command: 77 04 00 1F 23

Identifier (1byte)	Frame Length (1byte)	Address Code (1byte)	Command (1byte)	Data (0byte)	Checksum (1byte)
0x77	0x04		0x1F		

Command response:

Identifier (1byte)	Frame Length (1byte)	Address Code (1byte)	Command (1byte)	Data (1byte)	Checksum (1byte)
0x77	0x05		0x1F		

Note: The default address of the sensor is 0x00. When the query address command is sent, the returned data field is the hexadecimal device address.

2.10 Set output mode Command: 77 05 00 0C 00 11

Identifier (1byte)	Frame Length (1byte)	Address Code (1byte)	Command (1byte)	Data (1byte)	Checksum (1byte)
0x77	0x05		0x0C	0x00: question and answer Mode 0x01: 5Hz Data Rate 0x02: 10Hz Data Rate 0x03: 20Hz Data Rate 0x04: 25Hz Data Rate 0x05: 50Hz Data Rate 0x06: 100Hz Data Rate	

Note: The default output mode is 00(when setting 100HZ output frequency.
Set baud rate to 115200 in high speed mode.

Command response:

Identifier (1byte)	Frame Length (1byte)	Address Code (1byte)	Command (1byte)	Data (1byte)	Checksum (1byte)
0x77	0x05		0x8C	0x00: success 0xFF: failure	

Note: 5Hz Data Rate means that 5 sets of angle data are automatically output every second, and so on. When the product with the half-duplex RS485 interface is set to automatically outputs data to the outside, it may not be able to receive the input command effectively. At this point you may need to repeatedly send the command so that product can receive it. Therefore, if you need to send commands to interact with the product, it is recommended to set the product to work in Q&A mode. In addition, when the product is set to the automatic output mode, there will be no output within 10 seconds after the product is powered on, and the product can effectively receive the external setting command.

2.11 Save setting Command: 77 04 00 0A 0E

Identifier (1byte)	Frame Length (1byte)	Address Code (1byte)	Command (1byte)	Data (0 byte)	Checksum (1byte)
0x77	0x04		0x0A		

Command response:

Identifier (1byte)	Frame Length (1byte)	Address Code (1byte)	Command (1byte)	Data (1byte)	Checksum (1byte)
0x77	0x05		0x8A	0x00: success 0xFF: failure	

Note: If Save setting command is not executed, all setting will be invalid after power off.

Ordering Information

Product number	Way of communication	Package condition
SEC345-232	RS232	IP67 Package/Metal Connector
SEC345-485	RS485	IP67 Package/Metal Connector
SEC345-TTL	TTL	IP67 Package/Metal Connector

Executive standard

- Enterprise Quality System Standard: ISO9001:2008 Standard (Certificate No.:10114Q16846ROS)
- CE certification (certificate number: 3854210814)
- ROHS (certificate number: SO81426003)
- GB/T 191 SJ 20873-2003 General specifications for tiltmeters and spirit levels
- GBT 18459-2001 sensor main static performance index calculation method
- JF 1059-1999 Evaluation and Expression of Measurement Uncertainty
- GBT 14412-2005 mechanical vibration and shock mechanical installation of accelerometer
- General requirements for GJB 450A-2004 equipment reliability
- Quality control of key parts and important parts of GJB 909A
- GJB 899 Reliability Qualification and Acceptance Test
- GJB 150-3A high temperature test
- GJB 150-4A low temperature test
- GJB 150-8A rain test
- GJB 150-12A dust test
- GJB 150-16A vibration test
- GJB 150-18A impact test
- GJB 150-23A Tilt and Swing Test
- GB/T 17626-3A RF electromagnetic radiation immunity test
- GB/T 17626-5A surge (hit) impulse immunity test
- GB/T 17626-8A power frequency magnetic field immunity test
- GB/T 17626-11A voltage dips, short interruptions and voltage changes immunity

SEC345

**Inclination compensation
3D electronic compass**

Wuxi Bewis Sensing Technology LLC

Address: Building 30, No. 58 Xiuxi Road, Binhu District, Wuxi City

Hotline: 400-618-0510

Tel: +86 510 85737178-801

Email: sales@bwsensing.com

Website: www.bwsensing.com