



BW-IMU127 Series

Low-cost Modbus Inertial Measurement Unit

Technical Manual



Introduction

BW-IMU127 is a high-precision strapdown inertial measurement unit that can measure the angular velocity and acceleration of a moving carrier. The data deviation is estimated by the 6-state Kalman filter with appropriate gain, which is suitable for inertial attitude measurement in motion or vibration state.

BW-IMU127 uses highly reliable MEMS accelerometers and gyroscopes, and it uses algorithms to ensure measurement accuracy. At the same time, the sealing design and strict production process ensure that the product can accurately measure movement parameters such as the angular velocity, acceleration and attitude of the carrier in harsh environments. Through various compensations such as nonlinear compensation, quadrature compensation, temperature compensation and drift compensation, the error source of BW-IMU127 can be greatly eliminated and the product accuracy level can be improved. BW-IMU127 has a digital interface, which can be easily integrated into the user's system.

Feature

- Dynamic compensation, quadrature compensation
- Accuracy: 2°
- Special offset tracking algorithm eliminates drift
- Gyro drift compensation
- RS232 /485/TTL Output optional
- Wide temperature range: -40 °C~+85°C, Temperature compensation
- High-performance Kalman filter algorithm
- Small size: L55×W37×H24mm

Application

- Unmanned boat and underwater Robots
- Construction machinery
- Stable platform
- AGV unmanned guided vehicle
- Heavy Truck
- Unmanned drive
- Robots
- Unmanned aircrafts

Product Feature



Electrical index

| | |
|-----------------------|-----------------|
| Power voltage | 9-35V DC |
| Working current | 30mA (40mA max) |
| Operating temperature | -40~85°C |
| Storage temperature | -55~100°C |



Performance index

| | | |
|---------------|------------------------------------|--|
| Gyro | Resolution | 0.01°/sec |
| | Range | ±400°/sec |
| | Bias stability at room temperature | < 2°/h (100s, 1σ) < 100°/h (10s, 1σ) |
| | Angle random walk coefficient | < 0.1 °/√h |
| | Bias repeatability | < 50 °/h (1σ) |
| | Scale factor non-linearity | ≤100ppm (1σ) |
| | Scale factor repeatability | ≤100ppm (1σ) |
| | Bandwidth | 100Hz |
| Accelerometer | Range: X, Y, Z | 2g |
| | Resolution | 0.01mg |
| | Add zero offset | 0.15mg |
| | Bias stability | 0.001mg (25°C, 100s, 1σ) 0.01mg (25°C, 10s, 1σ) |

Resolution: The smallest change value of the measured value that the sensor can detect and distinguish within the measurement range.

Accuracy: The root mean square error of the actual angle and the sensor measuring angle for multiple (≥16 times) measurements.



Mechanical Index

| | |
|------------------|------------------------------------|
| Connector | Metal joint (Cable 1.5m) |
| Protection level | IP67 |
| Shell material | Magnesium aluminum alloy anodizing |
| Installation | Four M4 screws |



Package product size

Product size: L55*W37*H24 (mm)

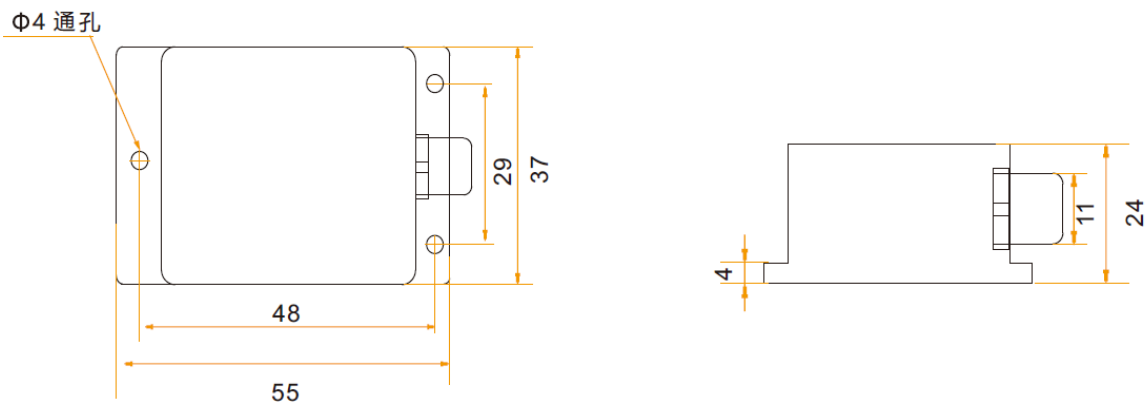

PCB size

Product size: L33*W27*H6 (mm) The length and width may have an error of ± 1 mm, please refer to the actual product

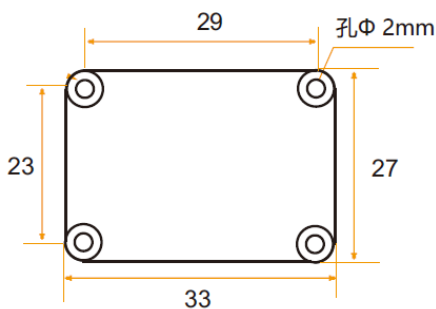

Installation

The correct installation method can avoid measurement errors. When installing the sensor, please do the following:

First of all, make sure that the sensor mounting surface is completely close to the measured surface, and the measured surface should be as level as possible, and there should be no included angles as shown in Figure A and Figure C. The correct installation method is shown in Figure B and Figure D.

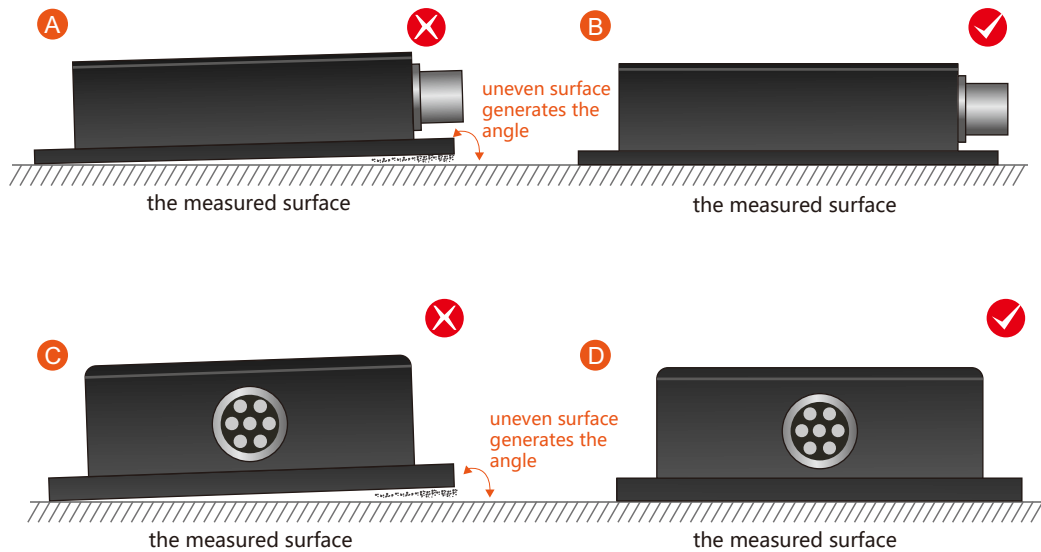

Secondly, the bottom line of the sensor and the axis of the measured object cannot have an angle as shown in Figure E. When installing, keep the bottom line of the sensor parallel or orthogonal to the axis of rotation of the measured object. This product can be installed horizontally or vertically (vertical installation needs to be customized), and the correct installation method is shown in Figure F.

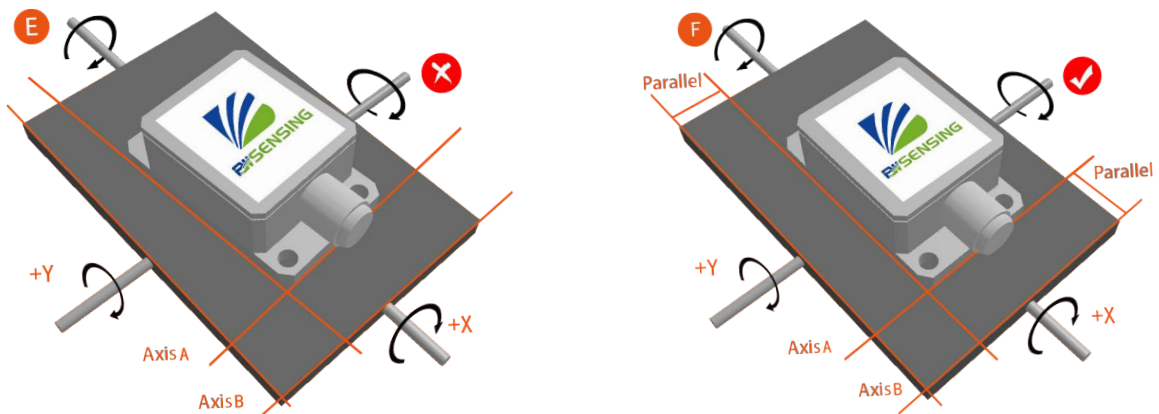

Finally, the mounting surface of the sensor and the surface to be measured must be tightly fixed, smooth in contact, and stable in rotation, and measurement errors due to acceleration and vibration must be avoided.

Electrical Connection

Wiring Definition

| | RED | BLUE | BLACK | GREEN | YELLOW |
|--------------|--------------|------|-------|---------------------|------------------|
| Wiring color | 1 | 2 | 3 | 4 | 5 |
| function | VCC DC 5V | NC | GND | Receive RXD B、D- | Send TXD A、D+ |

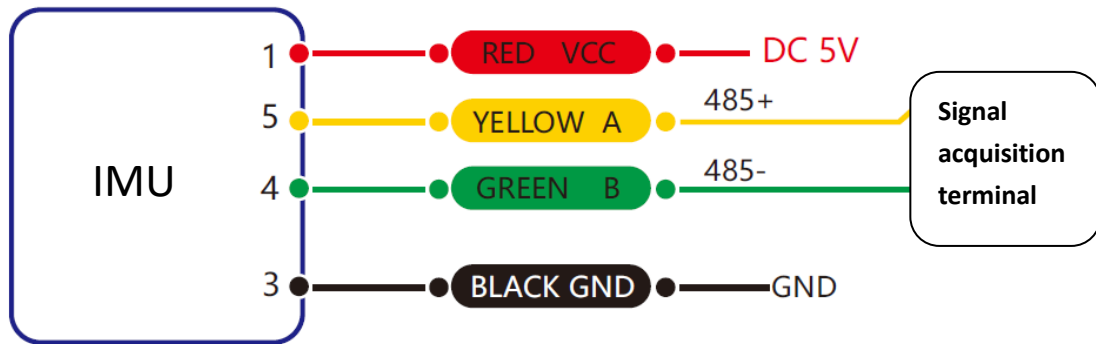

RS485 Wiring diagram

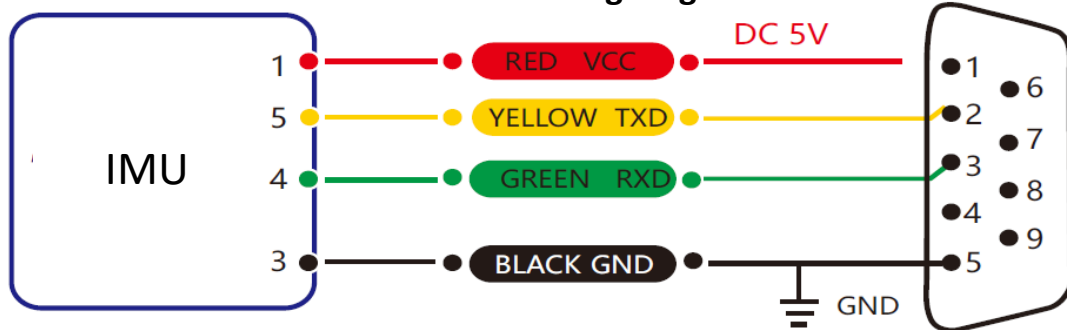

RS232 Wiring diagram

Debugging software

You can download the serial debugging assistant directly on the official website (technical service -> download area), or you can use the more convenient and intuitive host computer software.

BW-IMU127 supporting serial port debugging software can connect the inclination sensor on the computer to display the angle. The software debugging interface is shown in the figure below. Using the tilt angle to debug the host computer, you can easily display the current X and Y directions, and you can also modify and set other parameters.

Steps for use:

- ① Connect the serial port hardware of the inclinometer correctly, and connect the power supply.
- ② Select the correct device model (Choose Azimuth Series).
- ③ Select computer serial port and baud rate and click connect serial port.
- ④ Click start button and the current inclination angle of the inclinometer in X and Y directions will be displayed on the screen.

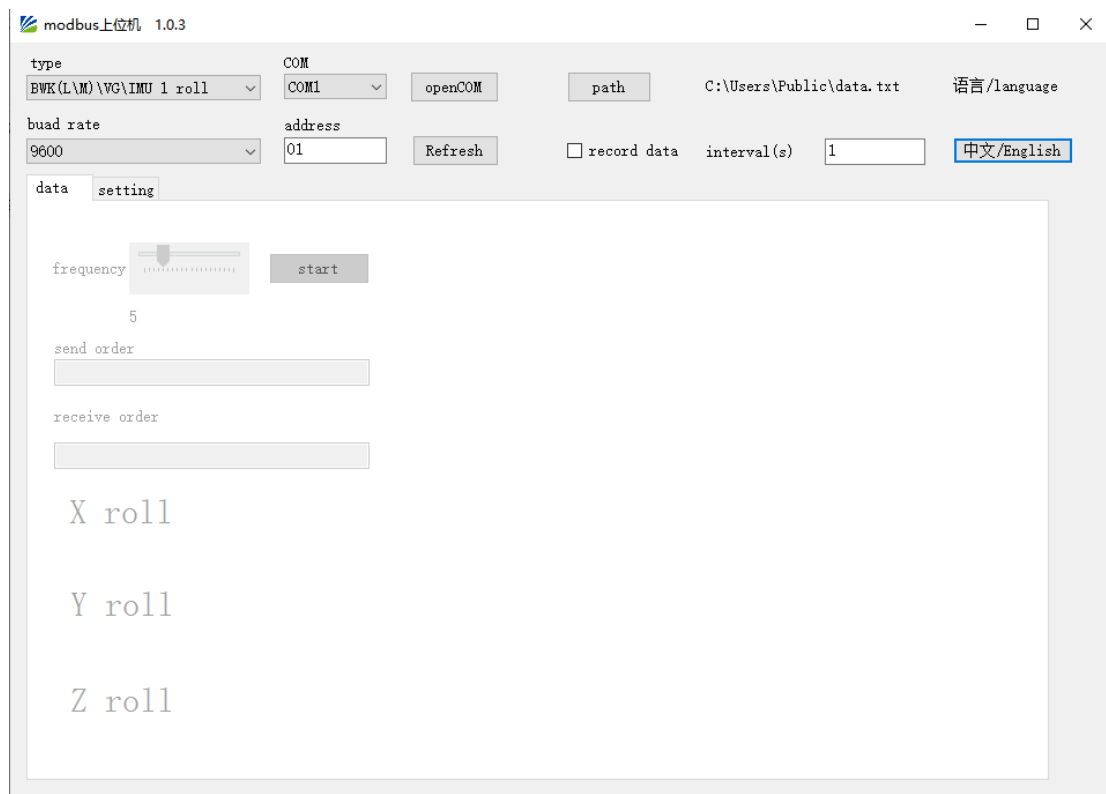

Order information

| Product model | Communication mode | Package situation |
|---------------|--------------------|---------------------------|
| BW-IMU127-485 | RS485 | IP67 Package /Metal joint |
| BW-IMU127-232 | RS232 | IP67 Package /Metal joint |
| BW-IMU127-TTL | TTL | IP67 Package /Metal joint |

Executive standard

- Enterprise Quality System Standard: ISO9001:2015 Standard (Certificate No.064-21-Q-3290-RO-S)
- CE certification (certificate number: M.2019.103. U Y1151)
- ROHS (certificate Number: G 190930099)
- GB/T 191 SJ 20873-2003 General specification for inclinometer and level
- GBT 18459-2001 The calculation method of the main static performance index of the sensor
- JJF 1059.1-2012 Evaluation and expression of measurement uncertainty
- GBT 14412-2005 Mechanical vibration and shock Mechanical installation of accelerometer
- GJB 450A-2004 General requirements for equipment reliability
- GJB 909A Quality control of key parts and important parts
- GJB899 Reliability appraisal and acceptance test
- GJB150-3A High temperature test
- GJB150-4A Low temperature test
- GJB150-8A Rain test
- GJB150-12A Sand and dust experiment
- GJB150-16A Vibration test
- GJB150-18A Impact test
- GJB150-23A Tilt and rock test
- GB/T 17626-3A Radio frequency electromagnetic field radiation immunity test
- GB/T 17626-5A Surge (impact) immunity test
- GB/T 17626-8A Power frequency magnetic field immunity test
- GB/T 17626-11A Immunity to voltage dips, short-term interruptions and voltage changes

BW-IMU127 Series

**Low-cost Modbus Inertial
Measurement Unit**

Wuxi Bewis Sensing Technology LLC

Add: Building 30, No.58 Xiuxi Road, Binhu District,
Wuxi City, Jiangsu Province, China

Tel: +86 18921292620

Email: sales@bwsensing.com

Web: www.bwsensing.com