



BW-VG227 Serials

**Low Cost Modbus Dynamic
Inclination Sensor**

Technical Manual



Introduction

The BW-VG227 Dynamic Inclination Sensor is a low-cost inertial measurement device that measures the attitude parameters (roll and pitch) of the motion carrier. The attitude deviation is estimated by a 6-state Kalman filter with appropriate gain and is suitable for tilt measurement in motion or vibration.

The BW-VG227 uses high-quality and reliable MEMS accelerometers and gyroscopes, and guarantees measurement accuracy through algorithms. At the same time, the seal design and strict process ensure that the product can accurately measure the roll angle and pitch angle of the carrier under harsh environment. Through various compensations such as nonlinear compensation, quadrature compensation, temperature compensation and drift compensation, the error caused by interference can be greatly eliminated, and the product precision level can be improved. The BW-VG227 has a digital interface that can be easily integrated into the user's system.

Features

- Nonlinear compensation, quadrature compensation
- Dynamic static measurement
- Special offset tracking algorithm eliminates the drift
- Gyro drift compensation
- RS232/RS485/TTL/Modbus interface output for optional
- Operating temperature: $-40^{\circ}\text{C}\sim+85^{\circ}\text{C}$
- High performance Kalman filter algorithm
- Small size: $L60 \times W59 \times H29\text{mm}$

Applications

- Ship
- Construction machinery
- Platform stability
- Agricultural machinery
- Special vehicle
- Driverless
- Robot
- Aircraft

Specifications

Electrical Specifications

Power supply	9-35V DC
Operating current	30mA (Max40mA)
Operating temperature	-40°C~85°C
Store temperature	-55°C~100°C

Performance Specifications

Attitude parameter	Dynamic accuracy	1°
	Static accuracy	0.1°
	Resolution	0.01°
	Tilt range	Pitch ± 90°, Roll ±180°
Physical characteristics	Size	L60 × W59× H29mm
	Weight (including cable)	280g
	Weight (including package)	360g
Interface characteristics	Start delay	<50ms
	Maximum output frequency	100Hz
	Serial communication rate	2400 to 115200 baud rate
	Digital output format	Binary high performance protocol
	Communication mode	RS232/RS485/TLL
MTBF	≥90000 hours/time	
Electromagnetic compatibility	According to GBT17626	
Insulation resistance	≥100 MΩ	
Impact resistance	2000g, 0.5ms, 3 times / axis	

Resolution: The measured minimum change value that the sensor can detect and resolve within the measurement range.

Accuracy: The error between the actual angle and the Root mean square(RMS) of the measured angle of the sensor (≥16 times).

Mechanical Characteristic

Connector	Metal connector (standard cable is 1.5m)
Protection level	IP67
Shell material	Magnesium alloy anodizing
Installation	Four M4 screws

Package size

Product Size: L60*W59*H29 (mm)

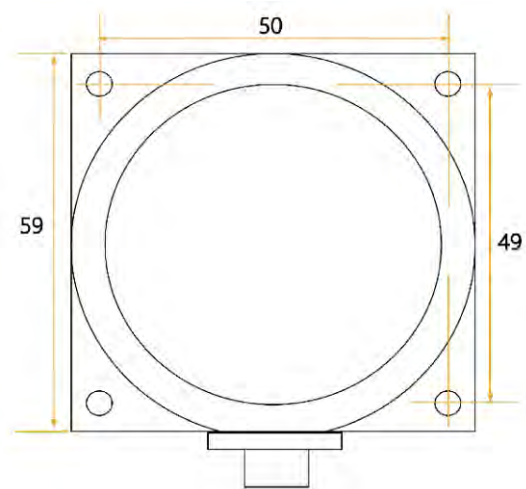
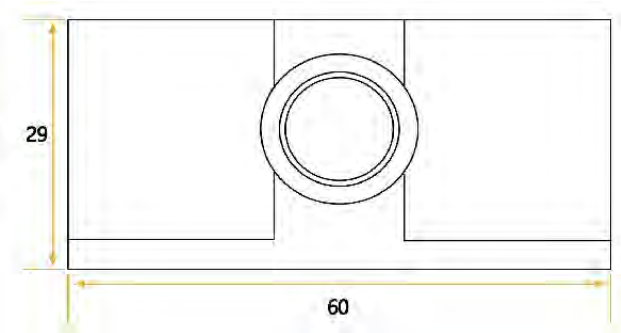

Bare plate product size

Product size: L44*W35*H11 (mm) **Note:** ±1mm error for length and width dimensions, please refer to actual size

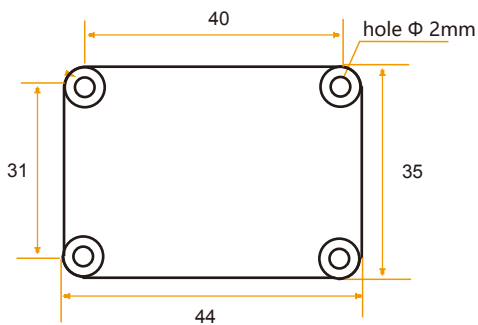

Installation direction

The correct installation method can avoid measurement error. The following points should be made when installing the sensor:

First of all, to ensure that the sensor mounting surface and the measured surface completely close, the measured surface should be as horizontal as possible, can not have the angle shown in Figure A and Figure C, the correct installation is shown in Figure B and Figure D.

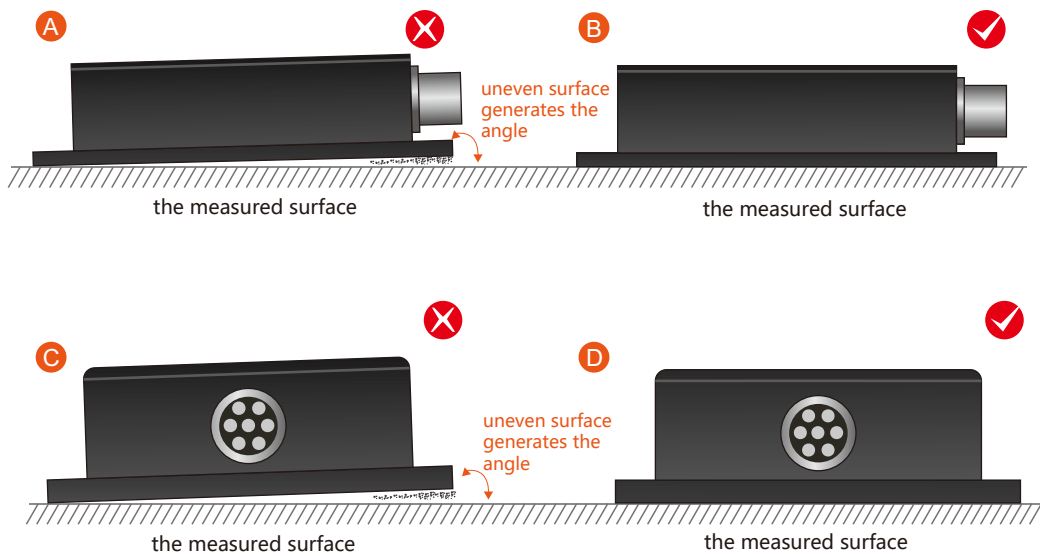

Secondly, the bottom cable of the sensor and the axis of the measured object shouldn't generate the angle shown in E. When installing, the bottom cable of the sensor should be kept parallel or orthogonal to the rotation axis of the measured object. This product can be installed horizontally or vertically (vertical installation requires customization). The correct installation method is shown in Figure F.

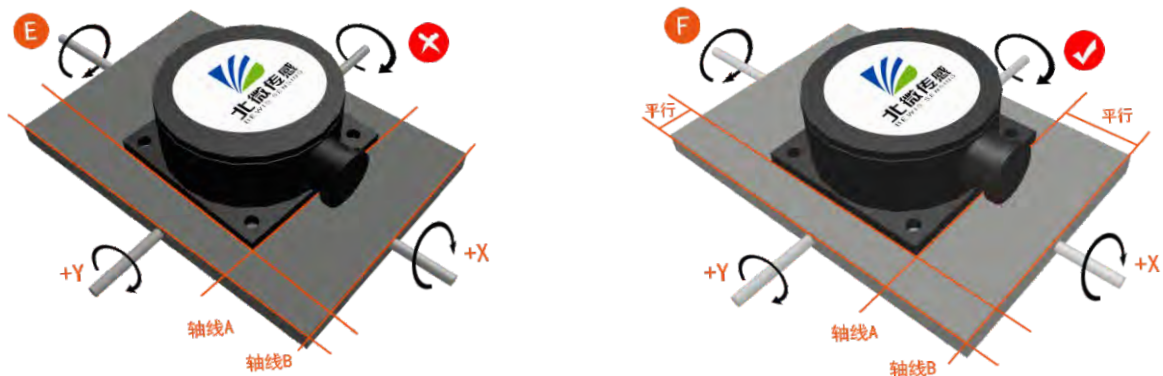

Finally, the installation surface of the sensor must be fixed with the measured surface tightly and smoothly, to avoid measurement error that may be caused by the acceleration and vibration.

Electrical connections

Electrical interfaces

Cable color & function	RED	BLUE	BLACK	GREEN	YELLOW
		1	2	3	4
	VCC DC 5V	NC	GND	RXD (B, D-)	TXD (A, D+)

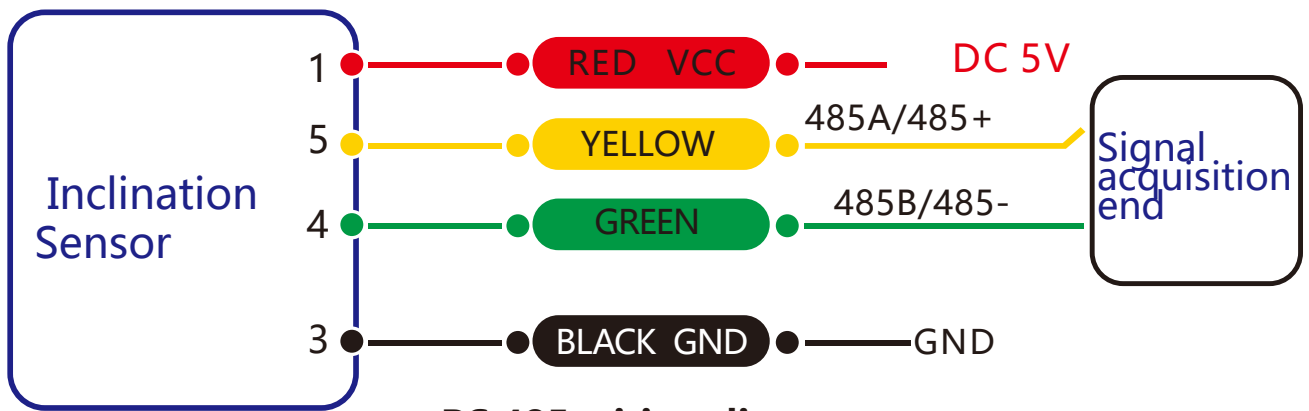

RS 485 wiring diagram

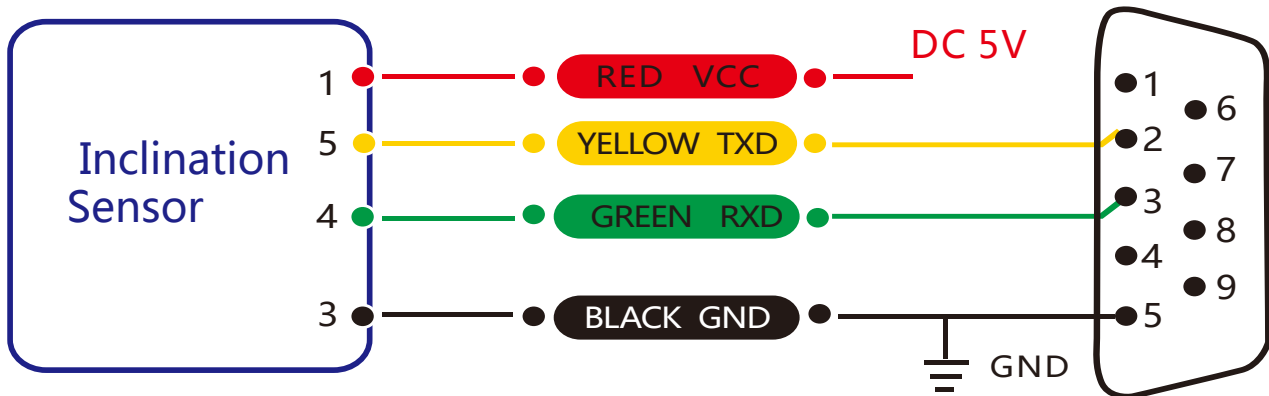

RS 232 wiring diagram

Debug software

Users can directly download serial assistant on official website (Supports-Download). You can also use more convenient and intuitive PC software.

BW-VG227 supporting serial debugging software can be connected to the inclinometer on the computer for angle display. The software debugging interface is as shown in the figure below. Using the debug software, it can conveniently display the current X-direction tilt angle, and you can also modify and set other parameters by yourself.

Software use steps:

- ① Connect the serial port hardware of the inclinometer correctly and connect the power supply.
- ② Select the correct device model (select azimuth series).
- ③ Select the computer serial port and baud rate and click to connect to the serial port.
- ④ Click Start and the tilt angle of the inclinometer in the X and Y directions will be displayed on the screen.

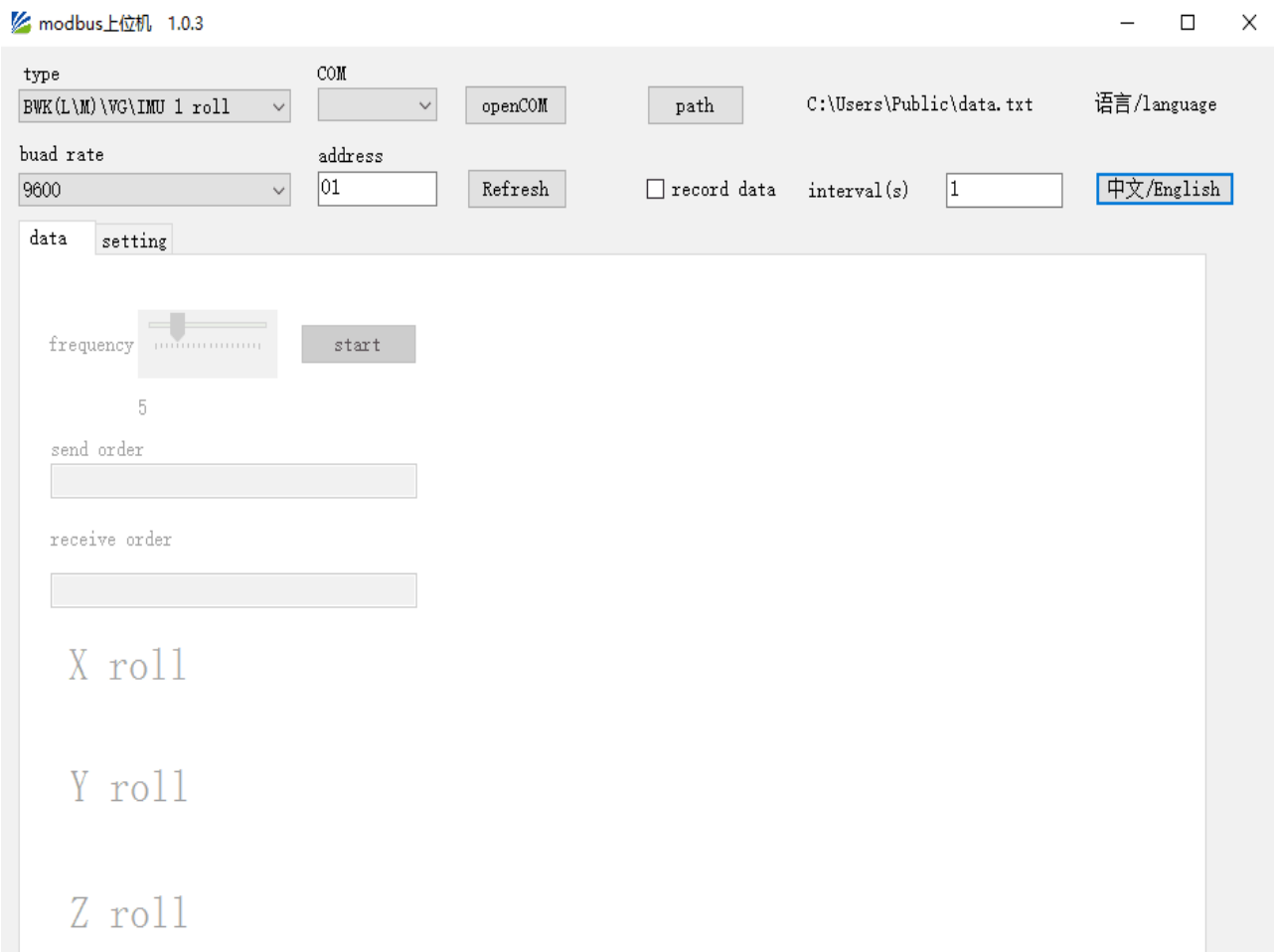

Protocol

1 Data Frame Format: (8 data bits, 1 stop bit, non verification, default rate 9600)

Address Code (1byte)	Function Code (1byte)	The first high address register (1byte)	The first low address register (1byte)	High register number (1byte)	Low register number (1byte)	CRC (2byte)
0x01	0x03 (read) 0x06 (write)	xx	xx	xx	xx	xxxx

Data format: Hexadecimal

Address code: Default 01 (**note:** it should not exceed 25)

Function Code: 03 represents reading register,06 represents presetting register.

Register Address: The starting address the register need to be operated

Register amount: The amount need to operate

Checksum: The CRC 16 (Modbus RTU) is calculated by the host (recommended by the CRC calculation software).

! \ ^ j k l i [x x j k f i x \ f i [\ i 1 0 \$ x o j x e ^ \ d 1 i \ \ ^ j k l i ' ' ' ' (' P \$ x o j x e ^ \ d 1 i \ \ ^ j k l i ' ' ' ') ' G i f [[i \ j j 1 i \ \ ^ j k l i ' ' ' ' * ' Q i f k p g \ 1 i \ \ ^ j k l i ' ' ' ' +

2 Command Format:

2.1 Read angle of X-axis Command: 01 03 00 01 00 01 D5 CA

Address Code (1byte)	Function Code (1byte)	The first high address register (1byte)	The first low address register (1byte)	High register number (1byte)	Low register number (1byte)	CRC (2byte)
0x01	0x03	0x00	0x01	0x00	0x01	0xD5CA

Command response:

Address Code (1byte)	Function Code (1byte)	Number of bytes (1byte)	High number (2byte)	Low number (2byte)	Wrong CRC checksum (2byte)
0x01	0x03	0x02	xx	xx	xxxx

Note: The data field is a hexadecimal number (PLC or configuration software uses 16-bit registers to directly read data in decimal). After conversion to decimal, the real data = (data field - 20,000) / 100. If the data field is 3D52, the conversion to decimal is 15698, the real data = (15698-20000) / 100 = -43.02°

2.2 Read angle of Y-axis Command: 01 03 00 02 00 01 25 CA

Address Code (1byte)	Function Code (1byte)	The first high address register (1byte)	The first low address register (1byte)	High register number (1byte)	Low register number (1byte)	CRC (2byte)
0x01	0x03	0x00	0x02	0x00	0x01	xxxx

Command response:

Address Code (1byte)	Function Code (1byte)	Number of bytes (1byte)	Data field high (2byte)	Data field low (2byte)	CRC (2byte)
0x01	0x03	0x02	xx	xx	xxxx

2.3 Read angle of both X-axis and Y-axis Command : 01 03 00 01 00 02 95 CB

Address Code (1byte)	Function Code (1byte)	The high address register (1byte)	The first low address register	High register number	Low register number	CRC (2byte)
0x01	0x03	0x00	0x01	0x00	0x02	xxxx

Command response:

Address Code (1byte)	Function Code (1byte)	Number of bytes (1byte)	The angle of X-axis (2byte)	The angle of Y-axis (2byte)	CRC (2byte)
0x01	0x03	0x04	xx xx	xx xx	xxxx

2.4 Set the communication rate

Command: 01 06 00 0B 00 02 79 C9

Address Code (1byte)	Function Code (1byte)	Function Code (1byte)	Function Code (1byte)	Data field (2byte)	CRC (2byte)
0x01	0x06	0x00	0x0B	0x0002	0x79 9C

Command response:

Address Code (1byte)	Function Code (1byte)	Function Code (1byte)	Function Code (1byte)	Data field (2byte)	CRC (2byte)
0x01	0x06	0x00	0x0B	0x0002	0x79 9C

Note:Data field is 0x00 00 represents 2400
 0x00 01 represents 4800
 0x00 02 represents 9600 (the default value)
 0x00 03 represents 19200
 0x00 04 represents 115200

2.5 Set relative/absolute zero
Command: 01 06 00 0A 00 00 A9 C8

Address Code (1byte)	Function Code (1byte)	Function Code (1byte)	Function Code (1byte)	Data field (2byte)	CRC (2byte)
0x01	0x06	0x00	0x0A	0000: absolute zero 0001: relative zero	0xA9 C8

Command response:

Address Code (1byte)	Function Code (1byte)	Function Code (1byte)	Function Code (1byte)	Data field (2byte)	CRC (2byte)
0x01	0x06	0x00	0x0A	0000: absolute zero 0001: relative zero	0xA9 C8

Note: absolute zero: Based on the factory-calibrated zero point.
relative zero: Reference to the zero after the current installation.

2.6 Query relative/absolute zero
Command: 01 03 00 04 00 01 C5 CB

Address Code (1byte)	Function Code (1byte)	The high address register (1byte)	The low address register (1byte)	High register number	Low register number	CRC (1byte)
0x01	0x03	0x00	0x04	0x00	0x01	0xC5 CB

Command response:

Address Code (1byte)	Function Code (1byte)	Number of bytes (1byte)	Data field high (1byte)	Data field low (1byte)	CRC (2byte)
0x01	0x03	0x02	xx	xx	xxxx

2.7 Set module address
Command: 01 06 00 0D 00 03 58 08

Address Code (1byte)	Function Code (1byte)	The high address register (1byte)	The low address register (1byte)	Data field (2byte)	CRC (2byte)
0x01	0x06	0x00	0x0D	Module address	XXXX

Command response:

Address Code (1byte)	Function Code (1byte)	The high address register (1byte)	The low address register (1byte)	Data field (2byte)	CRC (2byte)
XXXX	0x06	0x00	0x0D	Module address	XXXX

2.8 Save settings Command: 01 06 00 0F 00 00 B9 C9

Address Code (1byte)	Function Code (1byte)	The high address register (1byte)	The low address register (1byte)	High number of registers (1byte)	Data field (2byte)	Checksum (2byte)
0x01	0x06	0x00	0x0F	0x00	0x0000	0xB9C9

Command response:

Address Code (1byte)	Function Code (1byte)	The high address register (1byte)	The low address register (1byte)	Data field (2byte)	Checksum (2byte)
0x01	0x06	0x00	0x0F	0x0000	0xB9C9

Note: For all the previous setting items, you need to send the save command after modification. Otherwise, after power off, these settings will be restored to the state before the setting.

Ordering Information

Product number	Way of communication	Package condition
BW-VG227-232	RS232	IP67 Package/Metal Connector
BW-VG227-485	RS485	IP67 Package/Metal Connector
BW-VG227-TTL	TTL	IP67 Package/Metal Connector

Executive standard

- Enterprise Quality System Standard: ISO9001:2008 Standard (Certificate No.:10114Q16846ROS)
- CE certification (certificate number: 3854210814)
- ROHS (certificate number: SO81426003)
- GB/T 191 SJ 20873-2003 General specifications for tiltmeters and spirit levels
- GBT 18459-2001 sensor main static performance index calculation method
- JF 1059-1999 Evaluation and Expression of Measurement Uncertainty
- GBT 14412-2005 mechanical vibration and shock mechanical installation of accelerometer
- General requirements for GJB 450A-2004 equipment reliability
- Quality control of key parts and important parts of GJB 909A
- GJB 899 Reliability Qualification and Acceptance Test
- GJB 150-3A high temperature test
- GJB 150-4A low temperature test
- GJB 150-8A rain test
- GJB 150-12A dust test
- GJB 150-16A vibration test
- GJB 150-18A impact test
- GJB 150-23A Tilt and Swing Test
- GB/T 17626-3A RF electromagnetic radiation immunity test
- GB/T 17626-5A surge (hit) impulse immunity test
- GB/T 17626-8A power frequency magnetic field immunity test
- GB/T 17626-11A voltage dips, short interruptions and voltage changes immunity

BW-VG227

**Low Cost Modbus Dynamic
Inclination Sensor**

Wuxi Bewis Sensing Technology LLC

Address: Building 30, No. 58 Xiuxi Road, Binhu District, Wuxi City

Hotline: 400-618-0510

Tel: +86 510 85737178-801

Email: sales@bwsensing.com

Website: www.bwsensing.com