



# **BWH518 Series**

## **Current Single Axis Inclinometer**

# **Technical Manual**

V3.0



## Introduction

BWH518 is a single-axis high-precision inclinometer with MEMS technology and voltage output launched by Bewis. It has a measurement range of  $\pm 30^\circ$  and an accuracy of up to  $0.003^\circ$ . It is a cost-effective product. The product uses a high-resolution differential digital-to-analog converter with built-in automatic compensation and filtering algorithms to reduce errors caused by environmental changes. This product adopts the principle of non-contact measurement, through measuring the change of the static gravity field, it is converted into the change of the inclination angle, and the change directly outputs the current attitude angle through the voltage method. It is simple to use, small in size, resistant to external electromagnetic interference, and strong in vibration and impact. The recommended choice for inclination measurement in industries such as industrial automation, surveying and mapping!

## Feature

- Range:  $\pm 30^\circ$
- Wide voltage input: 12-36V
- Single axis inclination measurement
- Output: 0-20mA/4-20mA/0-24mA optional
- Highest accuracy:  $0.003^\circ$
- IP protection level: IP67
- High resolution:  $0.0007^\circ$
- Wide temperature work:  $-40^\circ\text{C} \sim +85^\circ\text{C}$

## Application

- Wind tower tilt monitoring
- Bridge and dam monitoring
- Railroad Gauge Ruler Leveling
- Exploration surveying and mapping equipment
- Lifting equipment inclination control
- Industrial automation attitude control
- High-precision platform leveling
- Construction machinery inclination measurement

## Product Features



### Electrical Index

Parameter	Condition	Minimum	Typical value	Maximum
Voltage (V)		12		36
Current (mA)	No load	20	50	40
Output load (KΩ)	Resistive	10		
Operating temperature(°C)		-40		85
Storage temperature(°C)		-55		100



### Performance Index

Measurement range (°)	Condition	±15	±30
Measurement axis		X-Y	X-Y
Accuracy(°)	Highest	0.003	0.005
Resolution(°)	Completely still	0.0007	0.0007
Zero bias (°/°C)	-40~85°C	±0.0007	±0.0007
Start-up time		< 3s	< 3s
Output frequency (Hz)	5-100Hz adjustable	Up to 100	Up to 100
Mean time between failures MTBF	≥90000 hours		
Electromagnetic compatibility	According to GBT17626		
Insulation resistance	≥100 MΩ		
Impact resistance	2000g, 0.5ms, 3times/axis		

**Resolution :** The smallest change in the measured value that the sensor can detect and distinguish within the measurement range.

**Accuracy:** The root mean square error between the actual angle and the angle measured by the sensor for multiple times (≥16 times).



## Mechanical Index

Connector	Metal joint (cable1.5m)
Protection Level	IP67*
Shell material	Magnesium aluminum alloy oxidation
Installation	Three M4 screws

\*Waterproof to IP67 after gluing



## Package product size

Product Size: L103.8\*W55.4\*H26 (mm)

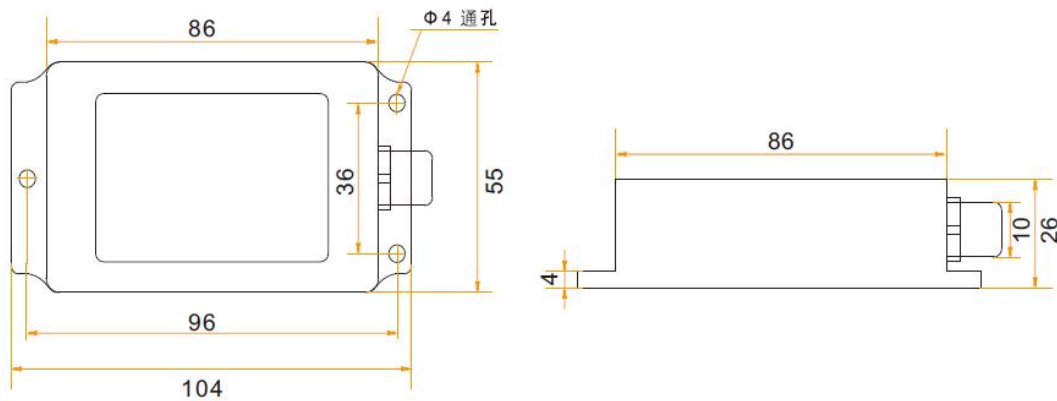

Top view



## Bare board product size

Product Size: L69\*W49\*H12 (mm) The length and width may have an error of  $\pm 1$  mm, please refer to the actual product

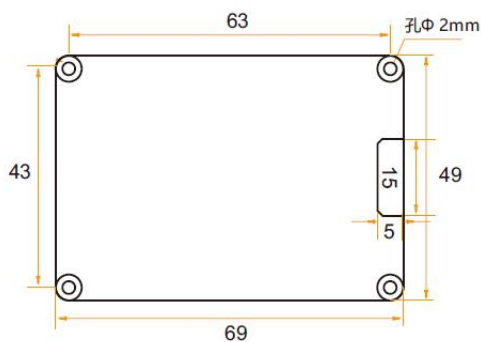

## Installation

The correct installation method can avoid measurement errors. When installing the sensor, please do the following:

First of all, make sure that the sensor mounting surface is completely close to the measured surface, and the measured surface should be as level as possible. There should be no included angles as shown in Figure A and Figure C. The correct installation method is shown in Figure B and Figure D.

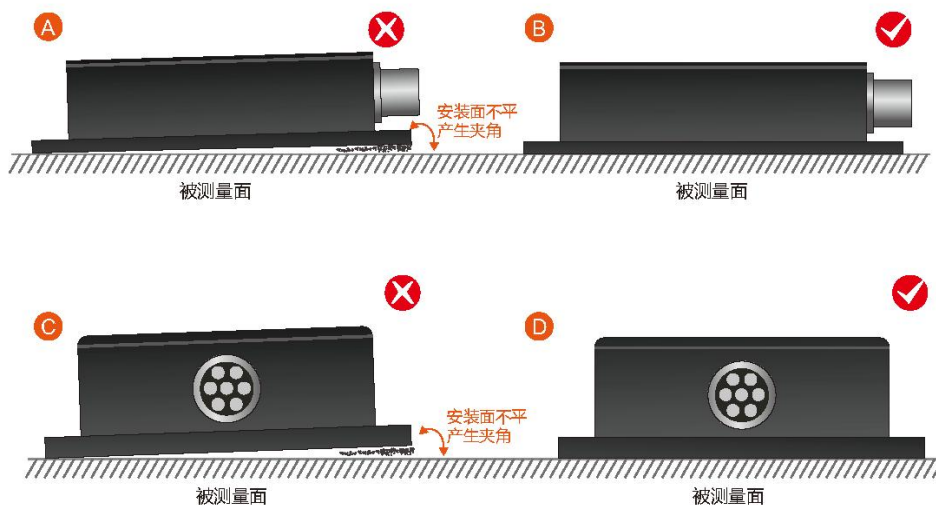

Secondly, the bottom line of the sensor and the axis of the measured object cannot have an angle as shown in Figure E, and the bottom line of the sensor should be kept parallel or orthogonal to the axis of rotation of the measured object during installation. This product can be installed horizontally or vertically (vertical installation needs to be customized), and the correct installation method is shown in Figure F.

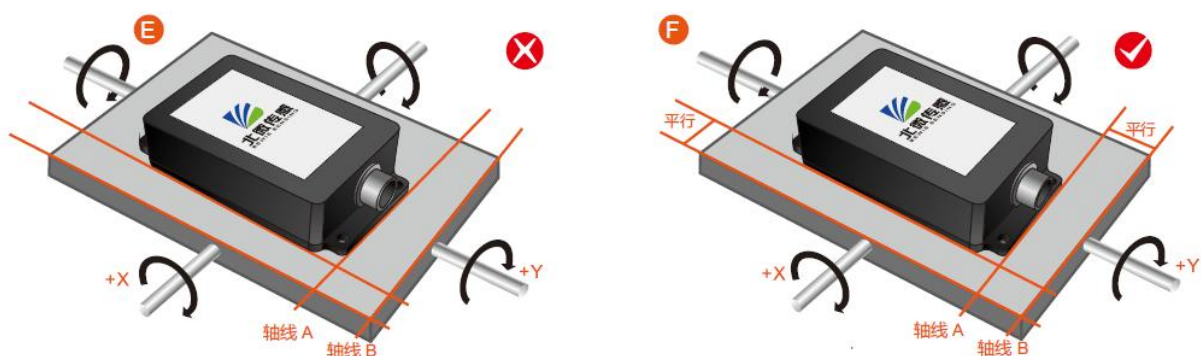

Finally, the mounting surface of the sensor and the surface to be measured must be tightly fixed, smooth in contact, and stable in rotation, and measurement errors due to acceleration and vibration must be avoided.

## Electrical Interface

Wiring definition

Line	<b>RED</b>	<b>BLACK</b>	<b>GREEN</b>	<b>YELLOW</b>	WHITE	GRAY
color	1	3	4	5	8	9
function	VCC DC 12-36V	GND	Receive RXD	Send TXD	X axis current output	Output place



RS232 wiring definition

Line color	<b>红色 RED</b>	<b>蓝色 BLUE</b>	<b>黑色 BLACK</b>	<b>绿色 GREEN</b>	<b>黄色 YELLOW</b>
function	1 VCC DC 12-36V	2 NC	3 GND ground	4 Receive RXD	5 Send TXD

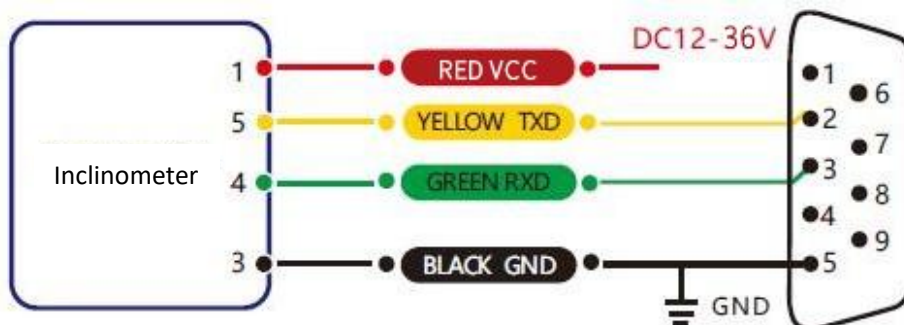

RS232 wiring diagram

## Test software

You can download the serial debugging assistant directly on the official website (technical service -> download area), or you can use the more convenient and intuitive host computer software.

The BWH518 supporting serial port debugging software can connect the tilt sensor on the computer to display the angle. The software debugging interface is as follows

As shown in the figure, using the tilt angle to debug the host computer, you can easily display the current tilt angle in the X direction, and you can also modify and set other parameters.

### Step:

- ① Connect the serial port hardware of the inclinometer correctly, and connect the power supply.
- ② Select computer serial port and baud rate and click connect serial port.
- ③ Click start button and the current inclination Angle of the incliner in X and Y directions will be displayed on the screen.

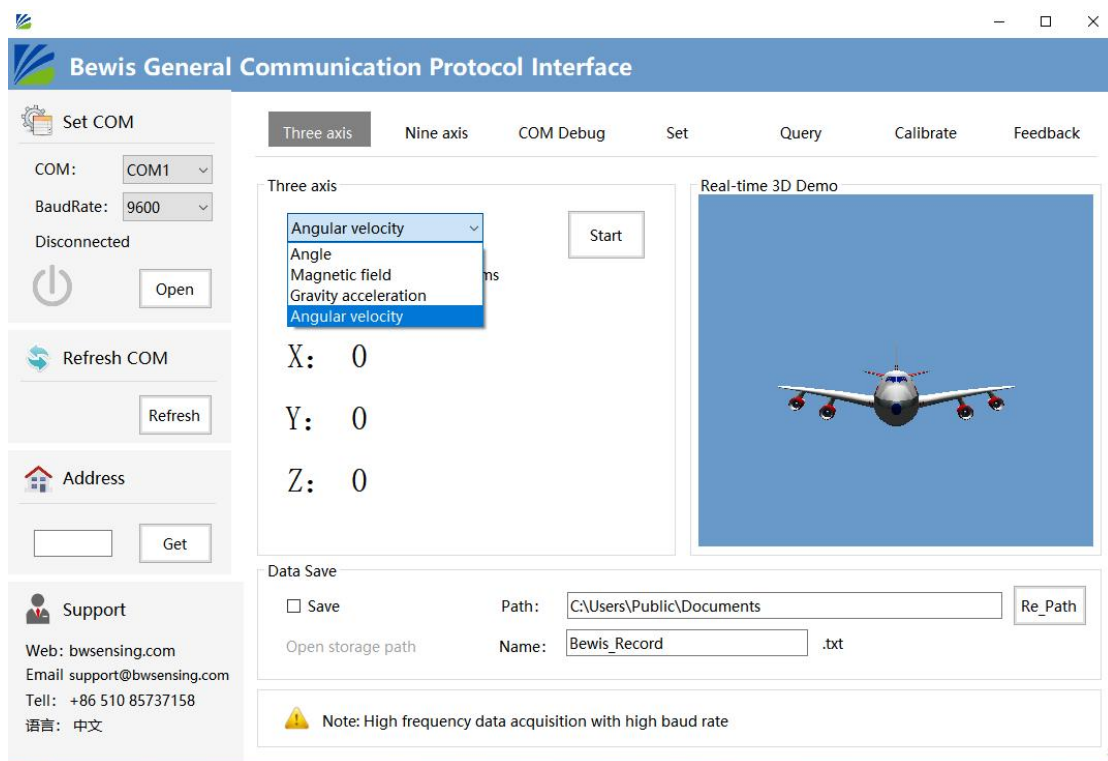

## Order information

Product Model	Communication mode	Package situation
BWH518-30-420	Current/RS232	IP67/Metal interface
BWH518-30-020	Current/RS232	IP67/Metal interface
BWH517-30-024	Current/RS232	IP67/Metal interface

## Executive standard

- Enterprise Quality System Standard: ISO9001:2015 Standard (Certificate No.23919Q10455R0S)
- CE certification (certificate number: M.2019.103. U Y1151)
- ROHS (certificate Number: G 190930099)
- GB/T 191 SJ 20873-2003 General specification for inclinometer and level
- GBT 18459-2001 The calculation method of the main static performance index of the sensor
- JJF 1059-1999 Evaluation and expression of measurement uncertainty
- GBT 14412-2005 Mechanical vibration and shock Mechanical installation of accelerometer
- GJB 450A-2004 General requirements for equipment reliability
- GJB 909A Quality control of key parts and important parts
- GJB899 Reliability appraisal and acceptance test
- GJB150-3A High temperature test
- GJB150-4A Low temperature test
- GJB150-8A Rain test
- GJB150-12A Sand and dust experiment
- GJB150-16A Vibration test
- GJB150-18A Impact test
- GJB150-23A Tilt and rock test
- GB/T 17626-3A Radio frequency electromagnetic field radiation immunity test
- GB/T 17626-5A Surge (impact) immunity test
- GB/T 17626-8A Power frequency magnetic field immunity test
- GB/T 17626-11A Immunity to voltage dips, short-term interruptions and voltage changes
- GB/T 2423.22-2012 Environment test  
The Second Part : Test Method Test N : Temperature change (IEC60068-2-14:2009,IDT)
- GB/T 10125-2012 Artificial atmosphere corrosion test Salt spray test (ISO 9227:2006.IDT)



# BWH518 Series

## Current Single Axis Inclinometer

### **Wuxi Bewis Sensing Technology LLC**

Add: Building 30, NO. 58, Xiuxi Road, Binhu District,  
Wuxi City, Jiangsu Province, China

Tel: +86 18921292620

Mail: [sales@bwsensing.com](mailto:sales@bwsensing.com)

Web: [www.bwsensing.com](http://www.bwsensing.com)