



BWL316S

**Low Cost Single-Axis
Digital Output Inclinometer
Technical Manual**



Introduction

Designed by Bewis Sensing Technology LLC, BWL316S is a low cost single-axis digital output inclinometer, adopting the latest industrial level MEMS accelerometer. Its measuring range is $\pm 180^\circ$, highest accuracy is 0.1° , working temperature is $-40^\circ\text{C}\sim +85^\circ\text{C}$, the product with a small size and low weight, can meet space-restricted application requirements.

This product converts static gravity field changes into angle changes, It outputs horizontal angle values directly by digital, this product has the advantages of low cost, small temperature drift, simple to use, and strong resistance to external disturbances. It is an ideal option for attitude measurement in photovoltaic power (PV) , PTZ control, tower turbines monitoring and other industries.

Features

- Single-axis inclinometer measurement
- Resolution: 0.01°
- Voltage input: 9~35VDC
- Product size: L55×W37×H24(mm)
- Accuracy: 0.1°
- Measuring range: $\pm 180^\circ$
- IP67 protection
- Output interface: RS232/485/TTL optional

Applications

- Industrial automatic leveling
- Medical devices
- PV automatic tracking
- Tower tilt monitoring
- Special valves
- Oil drilling equipment
- Industrial converters
- Crane tilt angle control

Specifications

Electrical Specifications

Parameters	Conditions	Min	Typical	Max	Units
Power supply(DC)		9	12	35	V
Operating current	Non-loaded	20	30	40	mA
Operating temperature		-40		+85	°C
Store temperature		-55		+100	°C

Performance Specifications

Measuring range(°)	Conditions	±10	±30	±60	±90	±180
Measuring axis		X	X	X	X	X
Accuracy(°)	Indoor	0.1	0.1	0.1	0.2	0.2
Resolution(°)		0.01	0.01	0.01	0.01	0.01
Zero temperature drift(°/°C)	-40 ~ +85°C	±0.01	±0.01	±0.01	±0.01	±0.01
Frequency response (Hz)		100	100	100	100	100
Baud rate	2400~115200					
MTBF	≥ 100000 h					
Electromagnetic compatibility	According to GBT17626					
Insulation resistance	≥100MΩ					
Shock resistance	2000g,0.5ms,3times/axis					
Weight (g)	210g					

Resolution: The measured minimum change value that the sensor can detect and resolve within the measurement range.

Accuracy: The error between the actual angle and the Root mean square(RMS) of the measured angle of the sensor (≥16 times).

Mechanical Characteristic

Connector	Metal connector
Protection level	IP67
Shell material	Magnesium alloy sanding oxidation
Installation	Three M4 screws

Package size

Product Size: L55*W37*H24 (mm)

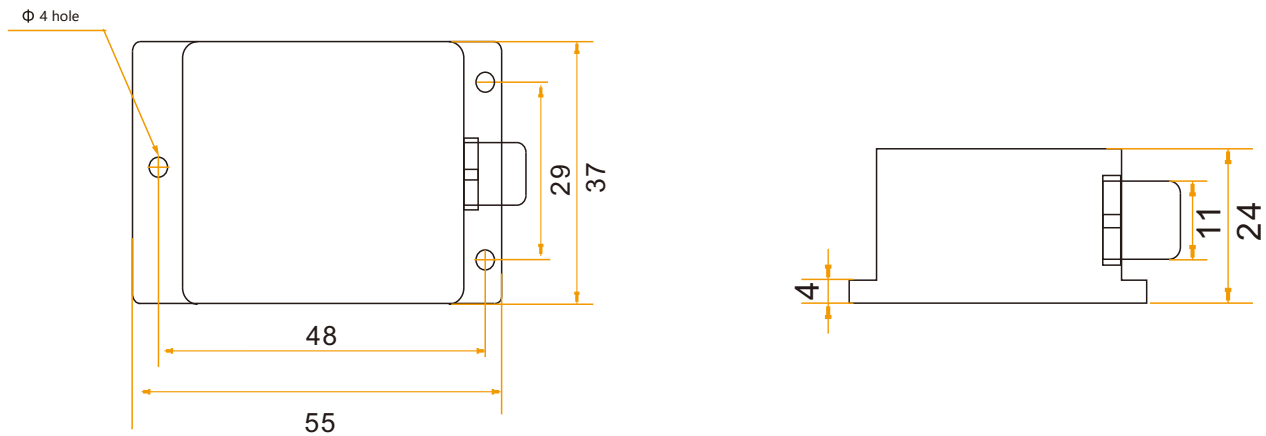

Bare plate product size

Product size: L33*W27*H6 (mm)

Note: ± 1 mm error for length and width dimensions, please refer to actual.

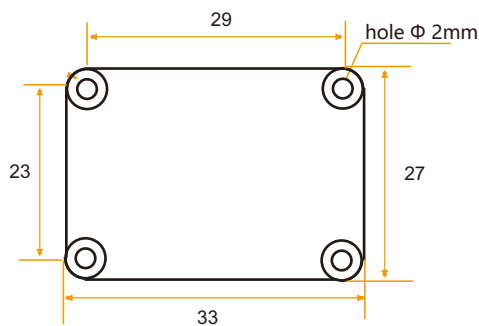

Installation direction

The correct installation method can avoid measurement error. The following points should be made when installing the sensor:

First of all, to ensure that the sensor mounting surface and the measured surface completely close, the measured surface should be as horizontal as possible, can not have the angle shown in Figure A and Figure C, the correct installation is shown in Figure B and Figure D.

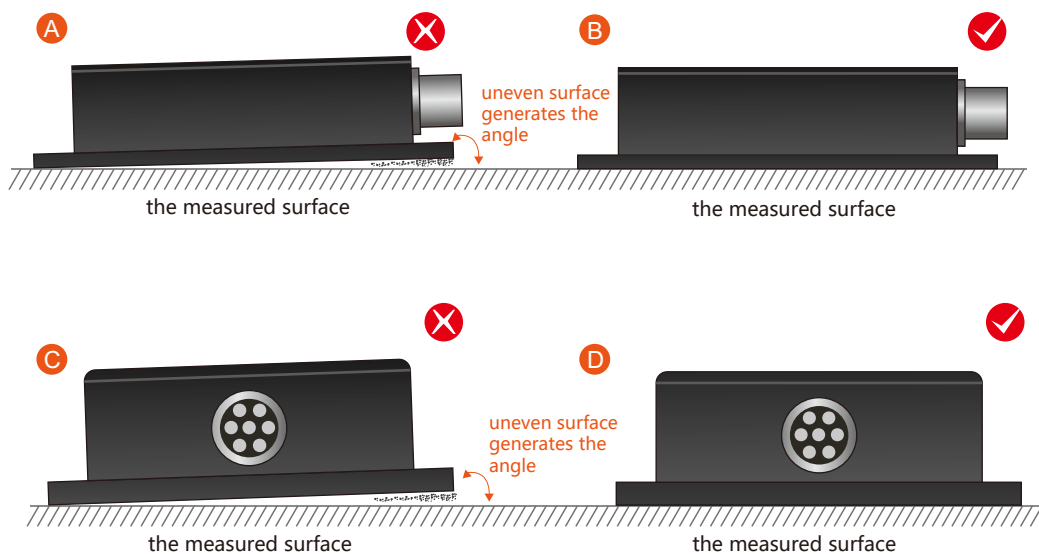

Secondly, the bottom cable of the sensor and the axis of the measured object shouldn't generate the angle shown in E. When installing, the bottom cable of the sensor should be kept parallel or orthogonal to the rotation axis of the measured object. This product can be installed horizontally or vertically (vertical installation requires customization). The correct installation method is shown in Figure F.

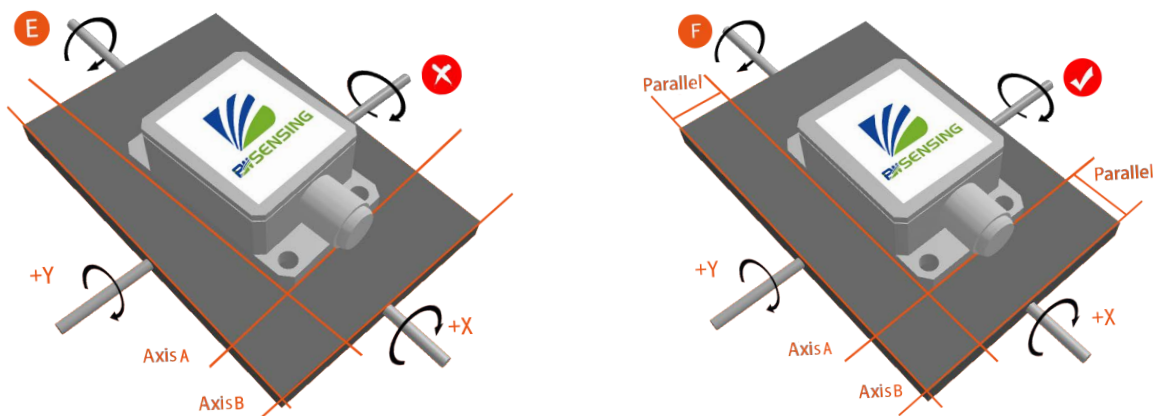

Finally, the installation surface of the sensor must be fixed with the measured surface tightly and smoothly, to avoid measurement error that may be caused by the acceleration and vibration.

Electrical connections

Electrical interfaces

cable color & function	RED	BLUE	BLACK	GREEN	YELLOW
	1	2	3	4	5
VCC 9-35VDC	NC	GND	RXD (B, D-)	TXD (A, D+)	

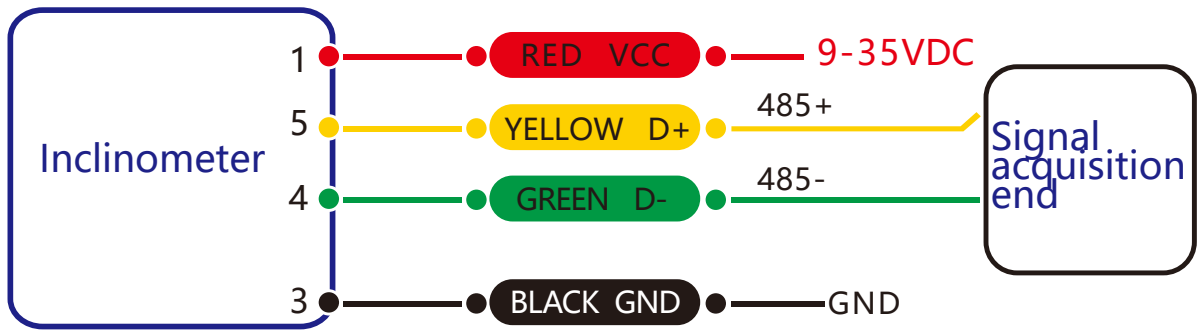

RS 485 wiring diagram

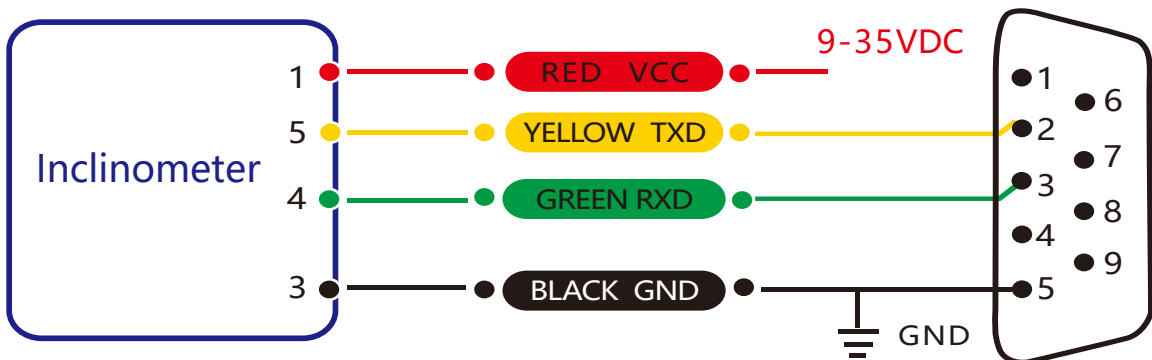

RS 232 wiring diagram

Debug software

Users can directly download serial assistant on official website (Supports-Download). You can also use more convenient and intuitive PC software.

BWL316S supporting serial debugging software can be connected to the inclinometer on the computer for angle display. The software debugging interface is as shown in the figure below. Using the debug software, it can conveniently display the current X-direction tilt angle, and you can also modify and set other parameters by yourself.

Software use steps:

- ① Correctly connect the inclinometer serial port hardware and connect the power supply.
- ② Select the computer serial port and baud rate and click connect Serial Port.
- ③ Click Start and the tilt angle of the tilter in the X direction will be displayed on the screen.

Note: You can switch to Chinese or English version by the bottom left button.

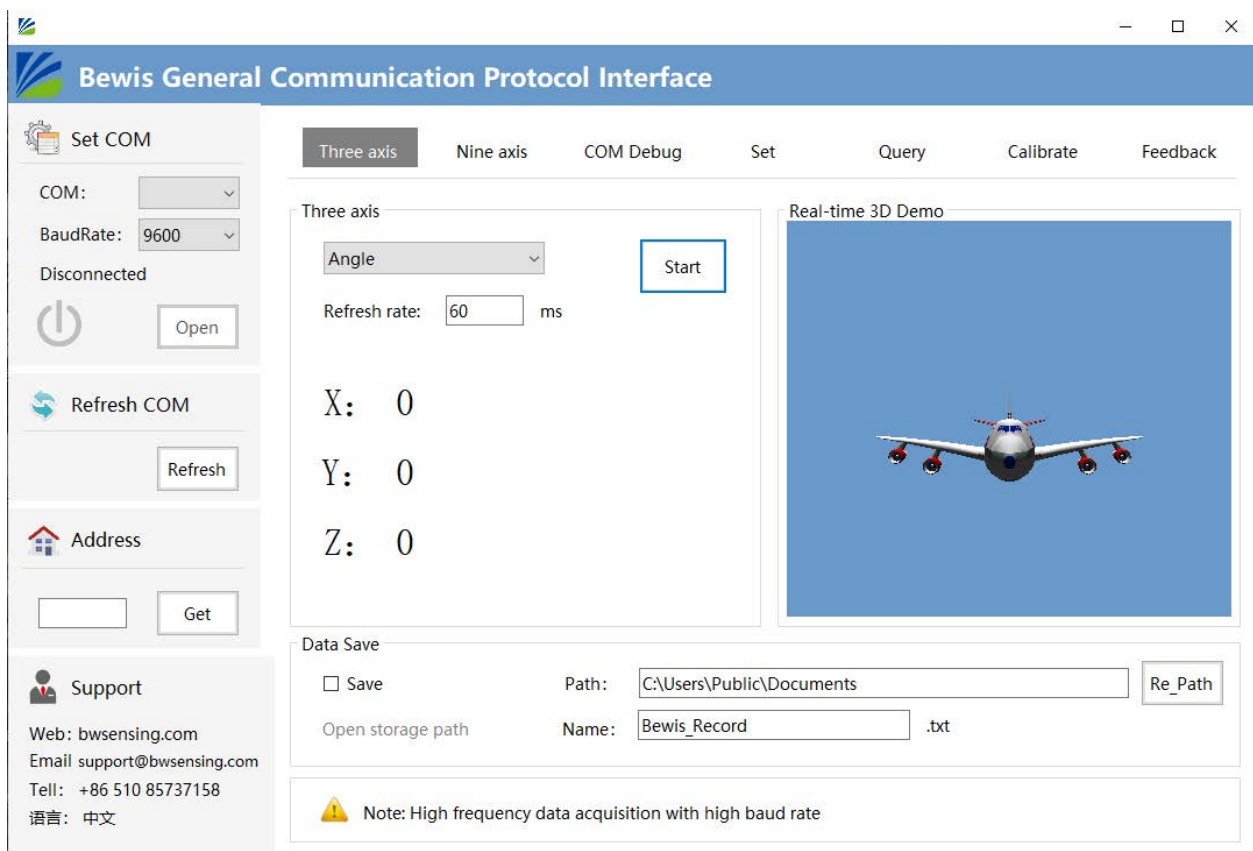

Protocol

1 Data Frame Format: (8 data bits, 1 stop bit, No parity check, default baud rate 9600)

Identifier (1byte)	Frame Length (1byte)	Address Code (1byte)	Command (1byte)	Data (xx byte)	Checksum (1byte)
0x77					

Data Format: Hexadecimal

Identifier: Fixed to 77

Frame Length: Length from Frame Length to Checksum (included)

Address Code: Address of acquiring module, default 0x00

Data: Content and length variable according to Command

Checksum: Sum of Frame Length, Address Code, Command and Data. (Please pay attention that when the command or data changes, the checksum will change.)

2 Command Format

2.1 Read angle of X axis Command: 77 04 00 01 05

Identifier (1byte)	Frame Length (1byte)	Address Code (1byte)	Command (1byte)	Data (0byte)	Checksum (1byte)
0x77			0x01		

Command response:

Identifier (1byte)	Frame Length (1byte)	Address Code (1byte)	Command (1byte)	Data (3byte)	Checksum (1byte)
0x77	0x07		0x81	SXXX.YY	

Note: Data represents 3 byte angle value in format of compressed BCD code. S is the sign bit (0 means positive, 1 means negative), XXX is the three digit integer part, YY is the fractional part. The Data of other axis is the same format. For example, 10 26 80 means -26.8 °.

2.2 Set address Command: 77 05 00 0F 01 15

Identifier (1byte)	Frame Length (1byte)	Address Code (1byte)	Command (1byte)	Data (0byte)	Checksum (1byte)
0x77			0x0F	XX Address	

Command response:

Identifier (1byte)	Frame Length (1byte)	Address Code (1byte)	Command (1byte)	Data (1byte)	Checksum (1byte)
0x77			0x8F	0x00: success 0xFF: failure	

2.3 Set relative / absolute zero Command: 77 05 00 05 00 0A

Identifier (1byte)	Frame Length (1byte)	Address Code (1byte)	Command (1byte)	Data (1byte)	Checksum (1byte)
0x77			0x05	0x00: absolute zero 0x01: relative zero	

Command response:

Identifier (1byte)	Frame Length (1byte)	Address Code (1byte)	Command (1byte)	Data (1byte)	Checksum (1byte)
0x77			0x85	0x00: absolute zero 0xFF: relative zero	

Note: absolute zero: Based on the factory-calibrated zero point.
relative zero: Reference to the zero after the current installation.

2.4 Query relative / absolute zero Command: 77 04 00 1D 11

Identifier (1byte)	Frame Length (1byte)	Address Code (1byte)	Command (1byte)	Data (0byte)	Checksum (1byte)
0x77			0x0D	0x00: absolute zero 0x01: relative zero	

Command response:

Identifier (1byte)	Frame Length (1byte)	Address Code (1byte)	Command (1byte)	Data (1byte)	Checksum (1byte)
0x77			0x8D	0x00: absolute zero 0xFF: relative zero	

2.5 Set baud rate Command: 77 05 00 0B 03 13

Identifier (1byte)	Frame Length (1byte)	Address Code (1byte)	Command (1byte)	Data (1byte)	Checksum (1byte)
0x77			0x0B	0x00:2400 0x01:4800 0x02:9600 0x03:19200 0x04:115200	

Command response:

Identifier (1byte)	Frame Length (1byte)	Address Code (1byte)	Command (1byte)	Data (1byte)	Checksum (1byte)
0x77			0x8B	0x00: success 0xFF: failure	

Note: For data, 00: 2400, 01: 4800, 02: 9600, 03: 19200, 0x04:115200; Default 02:9600.

2.6 Query address Command: 77 04 00 1F 23

Identifier (1byte)	Frame Length (1byte)	Address Code (1byte)	Command (1byte)	Data (1byte)	Checksum (1byte)
0x77	0x04	0x00	0x1F		

Command response:

Identifier (1byte)	Frame Length (1byte)	Address Code (1byte)	Command (1byte)	Data (1byte)	Checksum (1byte)
0x77			0x1F		

2.7 Set output mode Command: 77 05 00 0C 00 11

Identifier (1byte)	Frame Length (1byte)	Address Code (1byte)	Command (1byte)	Data (1byte)	Checksum (1byte)
0x77			0x0C	0x00: question and answer Mode 0x01: 5Hz Data Rate 0x02: 10Hz Data Rate 0x03: 20Hz Data Rate 0x04: 25Hz Data Rate 0x05: 50Hz Data Rate 0x06: 100Hz Data Rate	

Note: The default output mode is 00(when setting 100HZ output frequency. Set baud rate to 115200 in high speed mode.

Command response:

Identifier (1byte)	Frame Length (1byte)	Address Code (1byte)	Command (1byte)	Data (1byte)	Checksum (1byte)
0x77			0x8C	0x00: success 0xFF: failure	

Note: Set to the response mode, it must receive the read angle command to output the angle. Set to automatic output system, it will automatically output the angle when power is turned on.

2.8 Save setting Command: 77 04 00 0A 0E

Identifier (1byte)	Frame Length (1byte)	Address Code (1byte)	Command (1byte)	Data (1byte)	Checksum (1byte)
0x77			0x0A		

Command response:

Identifier (1byte)	Frame Length (1byte)	Address Code (1byte)	Command (1byte)	Data (1byte)	Checksum (1byte)
0x77			0x8A	0x00: success 0xFF: failure	

Note: If Save setting command is not executed, all setting will be invalid after power off.

Executive standard

- Enterprise Quality System Standard: ISO9001:2008 Standard (Certificate No.10114Q16846ROS)
- CE certification (certificate number: 3854210814)
- RoHS (certificate number: G190930099)

BWL316S

Low Cost Single-Axis
Digital Output Inclinator

Wuxi Bewis Sensing Technology LLC

Address: Building 30, No. 58 Xiuxi Road, Binhu District, Wuxi City, Jiangsu Province, China

Tel/Whatsapp: +86 189 2129 2620

Email: support@bwsensing.com

Website: www.bwsensing.com