



BWS5000 Series

High-precision Digital Output Dual Axis Inclinometer

Technical Manual

V3.0



Introduction

BWS5000 is a dual-axis high-precision Inclinometer with MEMS technology and digital output launched by Bewis Sensing. It has a measurement range of $\pm 15^\circ$, a maximum accuracy of 0.001° , and a temperature drift of $0.0003^\circ/\text{C}$. It is currently the highest accuracy product in the industry. The sensor uses a high-resolution differential digital-to-analog converter with built-in automatic compensation and filtering algorithms to minimize errors caused by environmental changes. Convert the change of the static gravity field into the change of the inclination angle, and directly output the current roll angle and pitch angle through the digital method. The product is easy to install, simple to use, small in size, resistant to external electromagnetic interference, and strong in vibration and impact. It is an industrial automation, The recommended choice for inclination measurement in surveying and mapping industries!

Feature

- Dual axis tilt measurement
- High accuracy: 0.001°
- Cross axis error: 0.001°
- Baud rate 2400~115200 adjustable
- Temperature drift $0.0003^\circ/\text{C}$
- Wide voltage input 9-36V DC
- Output frequency 5~100Hz adjustable
- RS485/RS232/TTL optional

Application

- Bridge deflection monitoring
- Building health monitoring
- Precision platform automatic leveling
- Equipment automation
- Tunnel and dam monitoring
- Tower tilt monitoring
- Surveying and Mapping Instruments
- Wind turbine tower monitoring

Product Feature



Electrical Index

Voltage (V)	9-36V DC
Working Current (mA)	50mA (12V) ; 40mA (24V)
Operating temperature(°C)	-40~85°C
Storage temperature(°C)	-55~100°C



Performance Index

Measurement Range (°)	Condition	±5	±15
Measurement axis	Mutually perpendicular	X-Y	X-Y
Accuracy (°)	Room temperature	0.001	0.003
Resolution (°)	Completely still	0.0001	0.0001
Zero bias (°/°C)	-40~85°C	±0.0003	±0.0003
Cross axis error (°)	-40~85°C	0.001	0.001
Start-up time		< 3s	< 3s
Output frequency (Hz)	5-100Hz adjustable	Up to 50	Up to 50
Baud rate	Adjustable	2400~115200	2400~115200
Mean time between failures MTBF	≥90000 h/time		
Electromagnetic compatibility	According to GBT17626		
Insulation resistance	≥100MΩ		
Impact resistance	2000g, 0.5ms, 3 times/axis		

Resolution : The smallest change in the measured value that the sensor can detect and distinguish within the measurement range.

Accuracy: The root mean square error between the actual angle and the angle measured by the sensor for multiple times (≥16 times).

Mechanical Index

Connector	Metal joint (cable1.5m)
Protection Level	IP67*
Shell material	Magnesium aluminum alloy oxidation
Installation	Four M4 screws

*Waterproof to IP67 after gluing

Package product size

Product Size: L90*W40.5*H36 (mm)

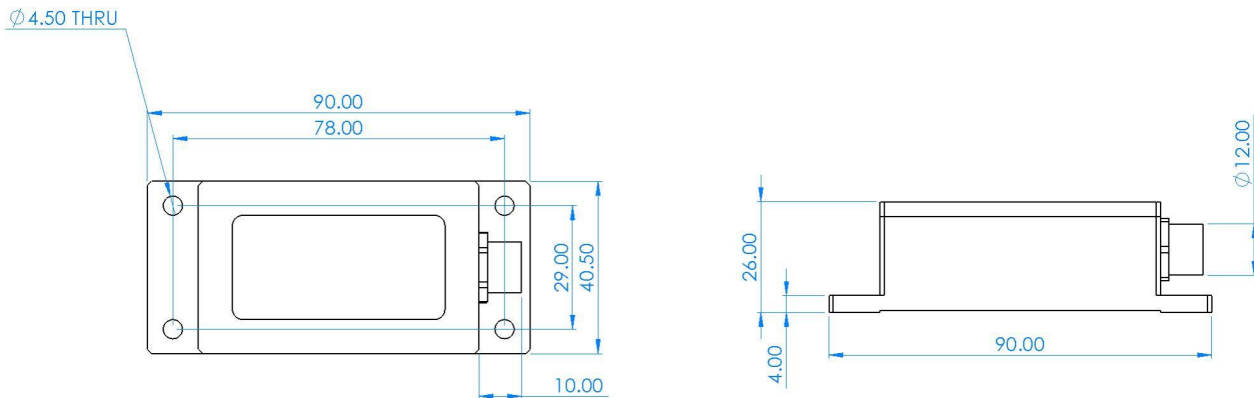

Bare board product

Product Size : L47*W36*H23 (mm) The length and width may have an error of ± 1 mm, please refer to the actual product

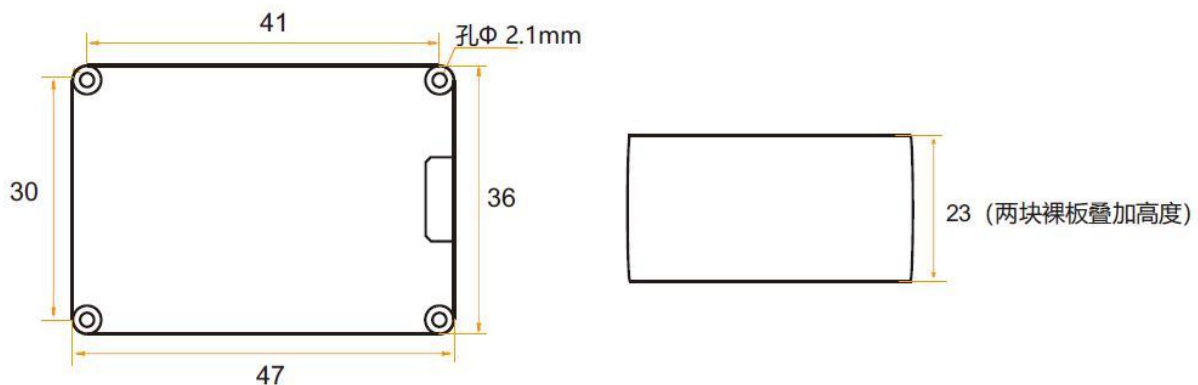

Installation

The correct installation method can avoid measurement errors. When installing the sensor, please do the following:

First of all, make sure that the sensor mounting surface is completely close to the measured surface, and the measured surface should be as level as possible. There should be no included angles as shown in Figure A and Figure C. The correct installation method is shown in Figure B and Figure D.

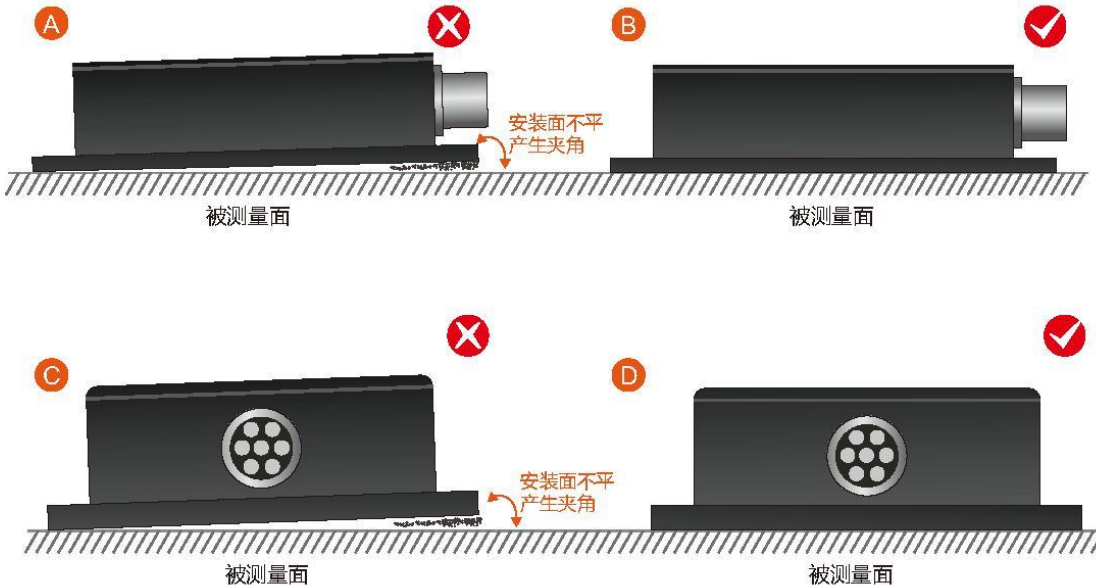

Secondly, the bottom line of the sensor and the axis of the measured object cannot have an angle as shown in Figure E, and the bottom line of the sensor should be kept parallel or orthogonal to the axis of rotation of the measured object during installation. This product can be installed horizontally or vertically (vertical installation needs to be customized), and the correct installation method is shown in Figure F.

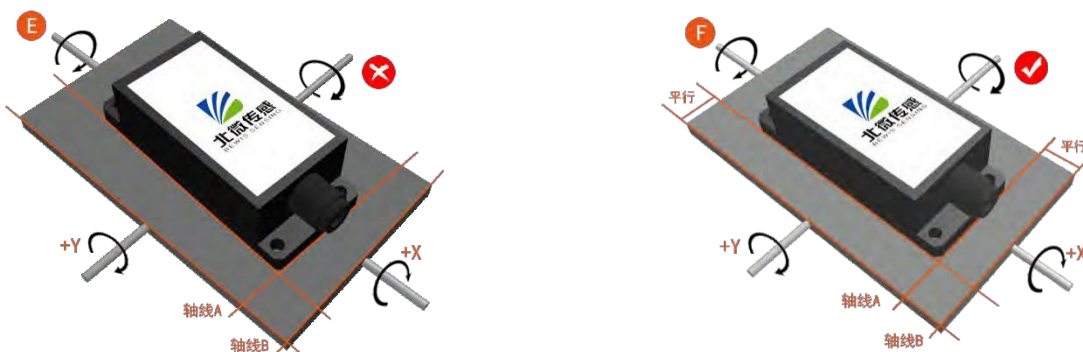

Finally, the mounting surface of the sensor and the surface to be measured must be tightly fixed, smooth in contact, and stable in rotation, and measurement errors due to acceleration and vibration must be avoided.

Electrical Interface

Wiring definition

Cable color & Function	RED	BLUE	BLACK	GREEN	YELLOW
	1	2	3	4	5
	VCC DC 9-36V	NC	GND	RXD (B, D-)	TXD (A, D+)

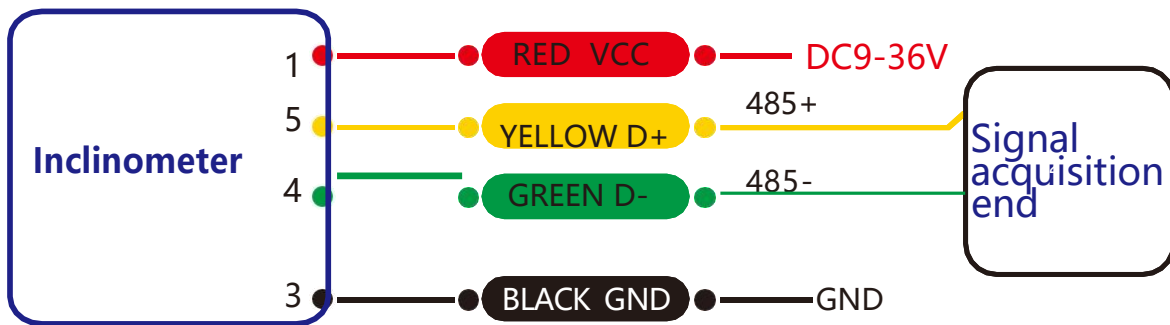

RS 485 wiring diagram

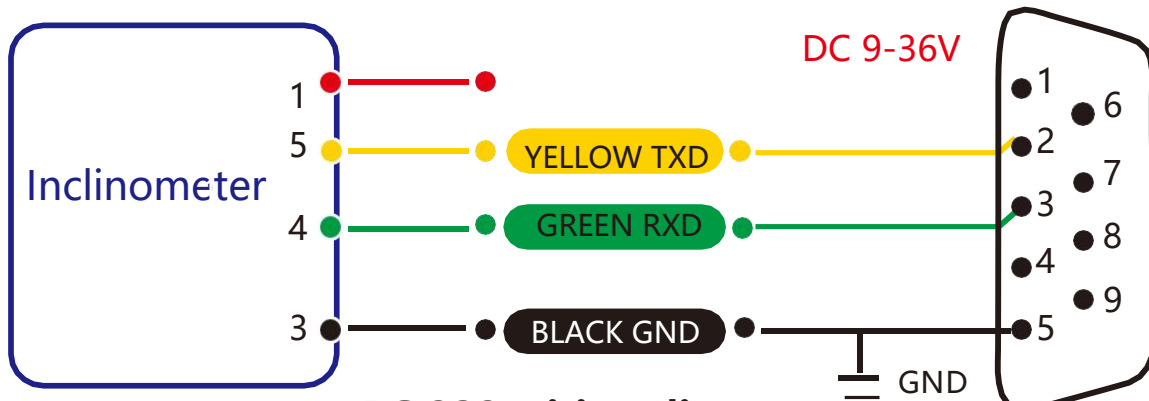

RS 232 wiring diagram

Debugging Software

You can download the serial debugging assistant directly on the official website (technical service -> download area), or you can use the more convenient and intuitive host computer software.

BWS5000 supporting serial port debugging software can connect the inclination sensor on the computer to display the angle. The software debugging interface is shown in the figure below. Using the tilt angle to debug the host computer, you can conveniently display the current X direction and Y direction tilt angle, and you can also modify and set other parameters.

Step:

- ① Connect the serial port hardware of the inclinometer correctly, and connect the power supply.
- ② Select computer serial port and baud rate and click connect serial port.
- ③ Click start button and the current inclination Angle of the incliner in X and Y directions will be displayed on the screen.

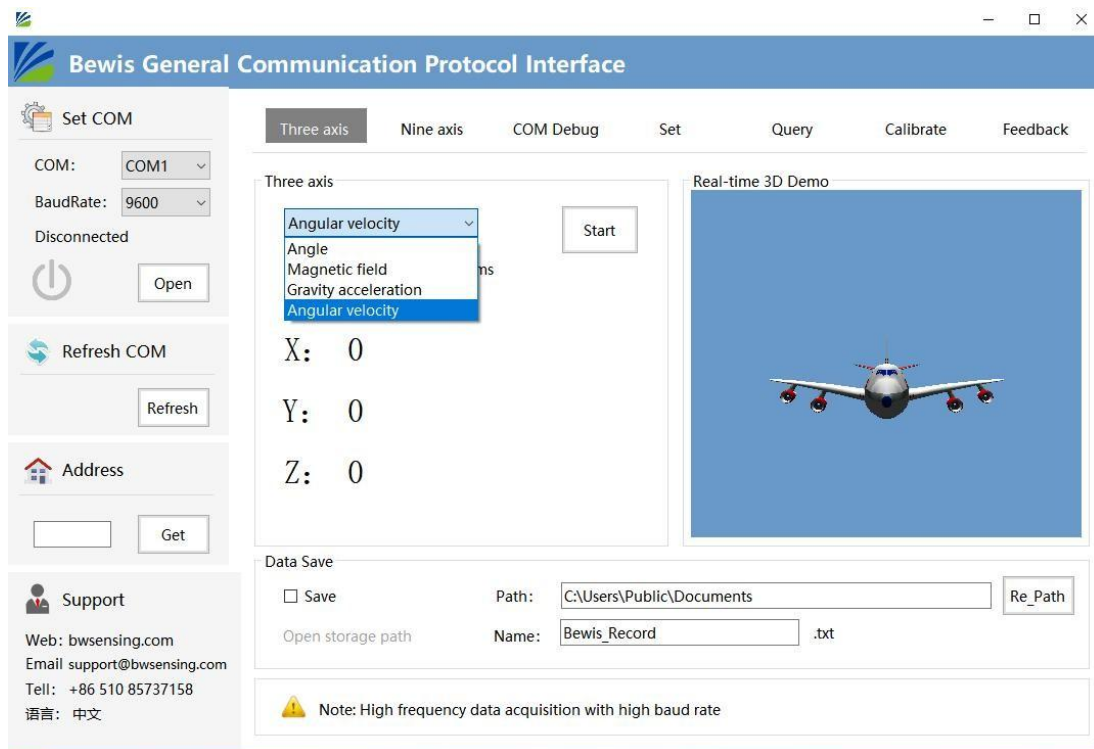

Order information

Product Model	Communication mode	Package situation
BWS5000-15-485	RS485	IP67/Metal interface
BWS5000-15-232	RS232	IP67/Metal interface
BWS5000-15-TTL	TTL	IP67/Metal interface

Executive standard

- Enterprise Quality System Standard: ISO9001:2015 Standard (Certificate No.064-21-Q-3290-RO-S)
- CE certification (certificate number: M.2019.103. U Y1151)
- ROHS (certificate Number: G 190930099)
- GB/T 191 SJ 20873-2003 General specification for inclinometer and level
- GBT 18459-2001 The calculation method of the main static performance index of the sensor
- JJF 1059-1999 Evaluation and expression of measurement uncertainty
- GBT 14412-2005 Mechanical vibration and shock Mechanical installation of accelerometer
- GJB 450A-2004 General requirements for equipment reliability
- GJB 909A Quality control of key parts and important parts
- GJB899 Reliability appraisal and acceptance test
- GJB150-3A High temperature test
- GJB150-4A Low temperature test
- GJB150-8A Rain test
- GJB150-12A Sand and dust experiment
- GJB150-16A Vibration test
- GJB150-18A Impact test
- GJB150-23A Tilt and rock test
- GB/T 17626-3A Radio frequency electromagnetic field radiation immunity test
- GB/T 17626-5A Surge (impact) immunity test
- GB/T 17626-8A Power frequency magnetic field immunity test
- GB/T 17626-11A Immunity to voltage dips, short-term interruptions and voltage changes
- GB/T 2423.22-2012 Environment test
The Second Part: Test Method Test N: Temperature change (IEC60068-2-14:2009,IDT)
- GB/T 10125-2012 Artificial atmosphere corrosion test Salt spray test (ISO 9227:2006,IDT)

BWS5000 Series

High-precision Digital Output Dual Axis Inclinometer

Wuxi Bewis Sensing Technology LLC

Add: Building 30, NO. 58, Xiuxi Road, Binhu District,
Wuxi City, Jiangsu Province, China

Tel: +89 18921292620

Mail: sales@bwsensing.com

Web: www.bwsensing.com