



DIS332 Series

Relay Single-Axis
Inclination Switch
Technical Manual



Introduction

Designed by Bewis Sensing Technology LLC, The DIS332 series is a single-axis inclination switch, with a measuring range of $\pm 180^\circ$. When the measured inclination angle exceeds the alarm threshold, the output line becomes closed (disconnected is also available). If the measured inclination does not exceed the alarm threshold, the output line is normally open (also normally closed). Thanks to the built-in solid state relay, the user does not need to reconfigure the extra relay. The maximum current in the normally closed state can reach 1A. The alarm threshold can be set according to the actual situation. The product is small in size, high in consistency and stability, its working temperature reaches the industrial grade $-40^\circ\text{C} \sim +85^\circ\text{C}$, which is a cost-effective inclination switch.

Features

- Single axis inclination monitoring optional
- Alarm threshold can be set arbitrarily
- Single line output alarm
- Voltage input: 9 ~ 35V
- Product size: 103.8*55.4*26mm
- Vibration resistance >2000g
- Resolution: 0.01°
- Temperature operation: $-40^\circ\text{C} \sim +85^\circ\text{C}$
- Accuracy: dynamic 2° / static 0.1°
- IP67 protection

Applications

- Hydraulic lifting platform
- High voltage wire tower monitoring
- Aerial work vehicle
- Cloud platform leveling
- Based on incline

Specifications

Electrical Specifications

Product number	DIS332			
Power Supply (V)	Conditions	Min	Typical	Max
		9	12	35
Operating current(mA)	Non-loaded		80	
Normally closed maximum current(mA)			100	
Operating temperature(°C)		-40		+85
Store temperature(°C)		-55		+100
Measuring range(°)		±180		
Accuracy(°)		dynamic 2°/ Static 0.1°		
Resolution(°)		0.01		
Measuring axis		X		
Alarm axis		X		
Zero temperature drift(°/°C)	-40~85°C	±0.01		
Frequency response (Hz)		100Hz		
Communication cable		9-core cable, 0.15mm ²]f i f e\		
Weight (g)		220 (1.5 m communication cable, package excluded)		

Resolution: The measured minimum change value that the sensor can detect and resolve within the measurement range.

Accuracy: The error between the actual angle and the Root mean square(RMS) of the measured angle of the sensor (≥16 times).

Mechanical Characteristic

Connector	Metal connector (standard cable is 1.5m)
Protection level	IP67
Shell material	Magnesium alloy anodizing
Installation	Three M4 screws

Package size

Product Size: L103.8*W55.4*H26 (mm)

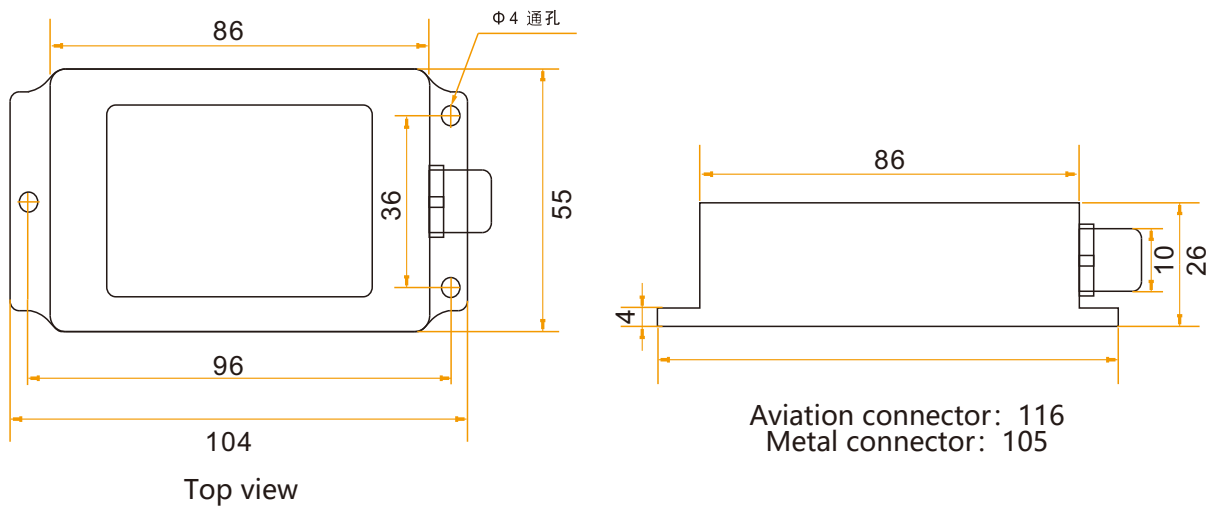

Bare plate product size

Product size: L69*W49*H12(mm)

Note: ± 1 mm error for length and width dimensions, please refer to actual size.

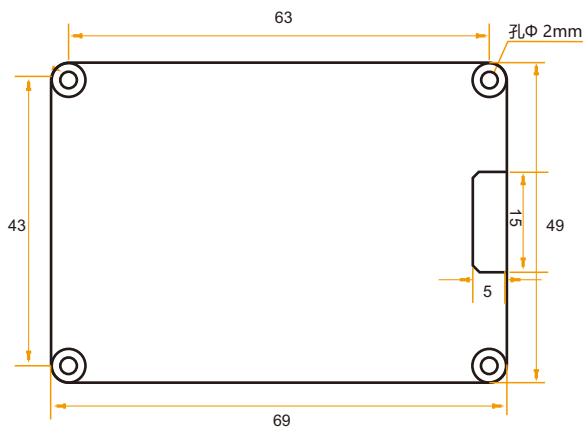

Installation direction

The correct installation method can avoid measurement error. The following points should be made when installing the sensor:

First of all, to ensure that the sensor mounting surface and the measured surface completely close, the measured surface should be as horizontal as possible, can not have the angle shown in Figure A and Figure C, the correct installation is shown in Figure B and Figure D.

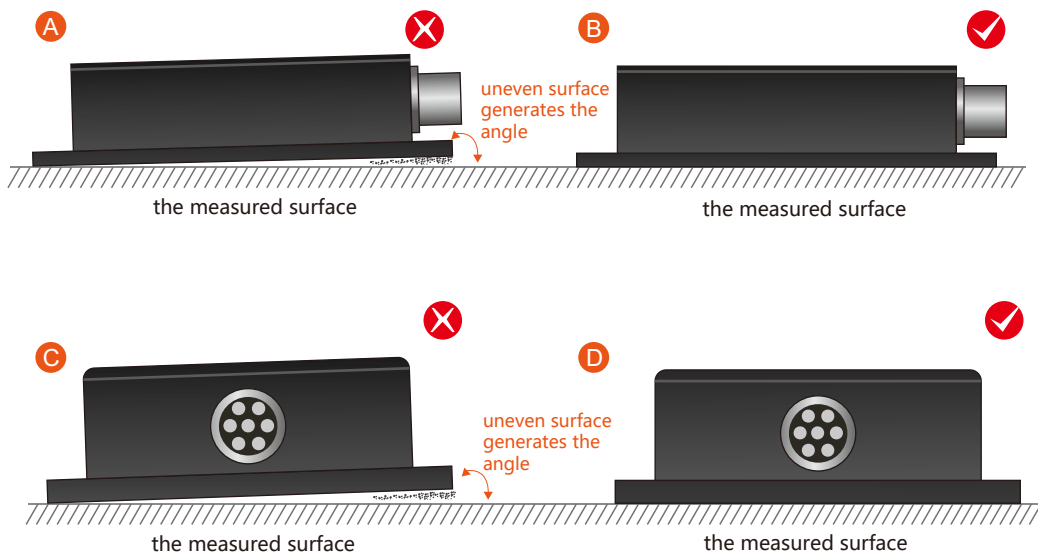

Secondly, the bottom cable of the sensor and the axis of the measured object shouldn't generate the angle shown in E. When installing, the bottom cable of the sensor should be kept parallel or orthogonal to the rotation axis of the measured object. This product can be installed horizontally or vertically (vertical installation requires customization). The correct installation method is shown in Figure F.

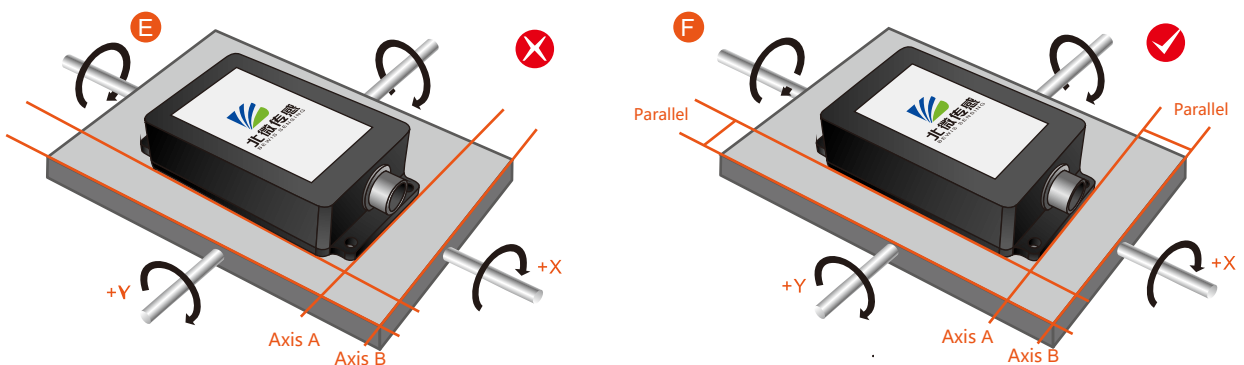

Finally, the installation surface of the sensor must be fixed with the measured surface tightly and smoothly, to avoid measurement error that may be caused by the acceleration and vibration.

Electrical Connections

Electrical interfaces

Cable color	RED	BLACK	GREEN	YELLOW	WHITE	PURPLE	BROWN	ORANGE
& Function	1	3	4	5	6	7	8	9
	VCC DC 9-35V	GND	RXD	TXD	U XOUT	U XOUT	NC	NC

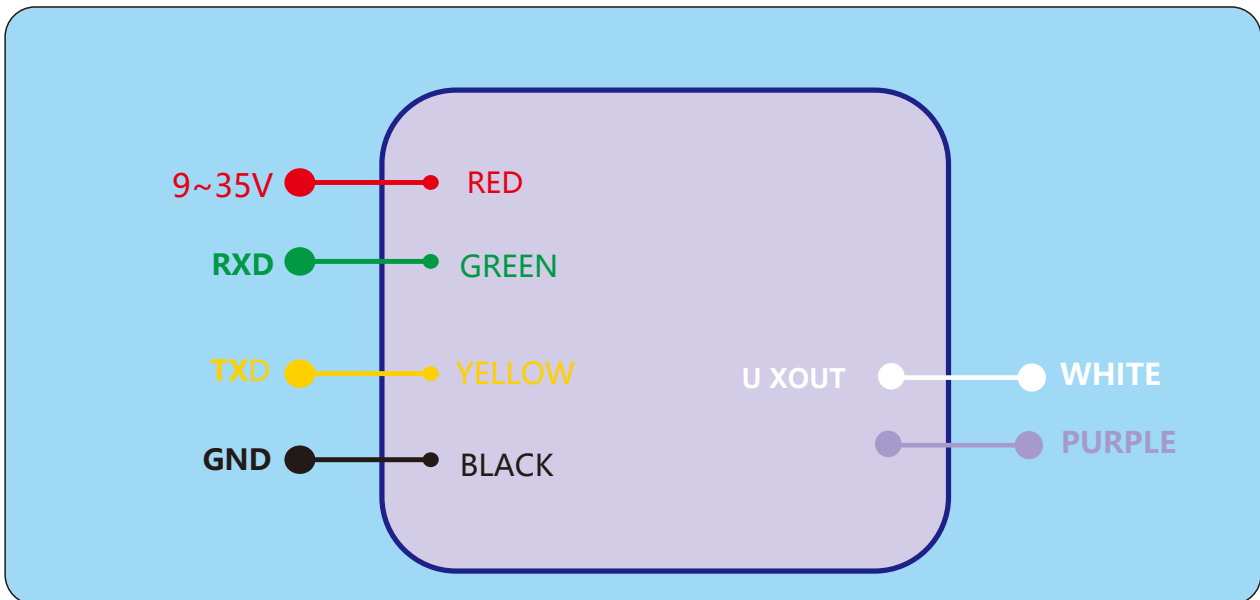

Debug software

Users can directly download serial assistant on official website (Supports-Download). You can also use more convenient and intuitive PC software.

DIS332 supporting serial debugging software can be connected to the inclinometer on the computer for angle display. The software debugging interface is as shown in the figure below. Using the debug software, it can conveniently display the current X-direction tilt angle, and you can also modify and set other parameters by yourself.

Software use steps:

- ① Correctly connect the inclinometer serial port hardware and connect the power supply.
- ② Select the computer serial port and baud rate and click connect Serial Port.
- ③ Click Start and the tilt angle of the tilter in the X direction will be displayed on the screen.

Note: You can switch to Chinese or English version by the bottom left button.

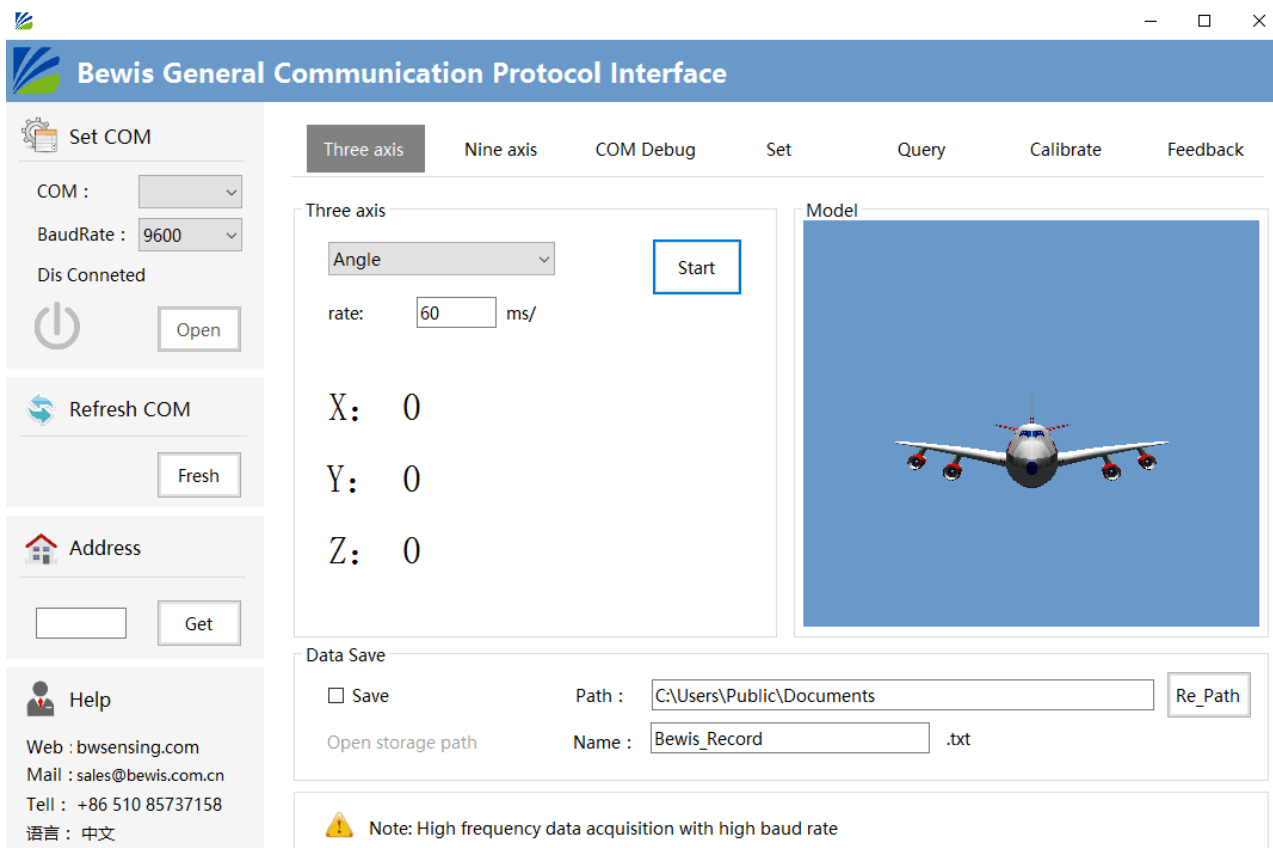

Protocol

1 Data Frame Format: (8 data bits, 1 stop bit, No parity check, default baud rate 9600)

Identifier (1byte)	Frame Length (1byte)	Address Code (1byte)	Command (1byte)	Data (Nbyte)	Checksum (1byte)
0x77					

Data Format: Hexadecimal

Identifier: Fixed to 77(partly 68)

Frame Length: Length from Frame Length to Checksum (included)

Address Code: Address of acquiring module, default 0x00

Data: Content and length variable according to Command

Checksum: Sum of Frame Length, Address Code, Command and Data. (Please pay attention that when the command or data changes, the checksum will change.)

2 Command format:

2.1 Read angle of X axis Command: 77 04 00 01 05

Identifier (1byte)	Frame Length (1byte)	Address Code (1byte)	Command (1byte)	Data (0byte)	Checksum (1byte)
0x77	0x04		0x01		

Command response:

Identifier (1byte)	Frame Length (1byte)	Address Code (1byte)	Command (1byte)	Data (3byte)	Checksum (1byte)
0x77	0x07		0x81	SXXX.YY	

Note: Data represents 3 byte angle value in format of compressed BCD code. S is the sign bit (0 positive, 1 negative), XXX is the three digit integer part, YY is the fractional part. The Data of other axis is the same format. For example, 10 26 80 means -026.80 °.

2.2 Set module address Command: 77 05 00 0F 01 15

Identifier (1byte)	Frame Length (1byte)	Address Code (1byte)	Command (1byte)	Data (1byte)	Checksum (1byte)
0x77	0X05	XX	0x0F	YY	

Command response:

Identifier (1byte)	Frame Length (1byte)	Address Code (1byte)	Command (1byte)	Data (1byte)	Checksum (1byte)
0x77	0X05	YY	0x8F	0x00	

XX indicates the address before modification, and YY indicates the modified address.

2.3 Set communication rate command: 77 05 00 0B 02 12

Identifier (1byte)	Frame Length (1byte)	Address Code (1byte)	Command (1byte)	Data (1byte)	Checksum (1byte)
0x77	0X05		0X0B	XX	

Response command:

Identifier (1byte)	Frame Length (1byte)	Address Code (1byte)	Command (1byte)	Data (1byte)	Checksum (1byte)
0x77	0X05		0x8B	0x00	

Sent data field XX is the baud rate option: 00 means 2400,
 01 means 4800,
 02 means 9600,
 03 means 19200,
 04 means 115200.

When the baud rate is low, the Angle transmission response is slow.

2.4 Query current address Command: 77 04 00 1F 23

Identifier (1byte)	Frame Length (1byte)	Address Code (1byte)	Command (1byte)	Data (0byte)	Checksum (1byte)
0x77	0x04	0x00	0x1F		

Response command:

Identifier (1byte)	Frame Length (1byte)	Address Code (1byte)	Command (1byte)	Data (1byte)	Checksum (1byte)
0x77	0x05	0xXX	0x1F	0xXX	

Note: XX represents the current address of the product.

2.5 Set the zero type Command: 77 05 00 05 01 0B

Identifier (1byte)	Frame Length (1byte)	Address Code (1byte)	Command (1byte)	Data (1byte)	Checksum (1byte)
0x77	0x05		0x05	0x00: absolute zero 0x01: relative zero	

Command response:

Identifier (1byte)	Frame Length (1byte)	Address Code (1byte)	Command (1byte)	Data (1byte)	Checksum (1byte)
0x77	0x05		0x85	0x00	

Note: absolute zero: Based on the factory-calibrated zero point.
 relative zero: Reference to the zero after the current installation.

2.6 Query the zero type Command: 77 04 00 0D 11

Identifier (1byte)	Frame Length (1byte)	Address Code (1byte)	Command (1byte)	Data (0byte)	Checksum (1byte)
0x77	0x04		0x0D		

Command response:

Identifier (1byte)	Frame Length (1byte)	Address Code (1byte)	Command (1byte)	Data (1byte)	Checksum (1byte)
0x77	0x05		0x8D	0x00: absolute zero 0xFF: relative zero	

2.7 Set alarm angle Command : 77 08 00 20 00 00 05 00 2D

Identifier (1byte)	Frame Length (1byte)	Address Code (1byte)	Command (1byte)	Data (4byte)	Checksum (1byte)
0x77	0x08		0x20	DSXXX.YY	

Response command:

Identifier (1byte)	Frame Length (1byte)	Address Code (1byte)	Command (1byte)	Data (1byte)	Checksum (1byte)
0x77	0x05		0xA0	00	

Note: D is the axis position in the data field. For example, 0x00 is the X-axis positive axis alarm angle, 0x02 is the X-axis positive axis alarm angle, S is a sign bit (0 positive, 1 negative), XXX is a three-digit integer value, and YY is a decimal value. The other axis data is the same.

For example, 01 00 26 80 indicates that the alarm value of the +Y axis is 26.8°.

2.8 Query alarm angle Command: 77 05 00 21 00 26

Identifier (1byte)	Frame Length (1byte)	Address Code (1byte)	Command (1byte)	Data (1byte)	Checksum (1byte)
0x77	0x05		0x21	0x00: +X 0x02: -X	

Response command:

Identifier (1byte)	Frame Length (1byte)	Address Code (1byte)	Command (1byte)	Data (4byte)	Checksum
0x77	0x08		0xA1	DSXXX.YY	

2.9 Set alarm delay on time Command: 77 07 00 23 00 05 00 2F

Identifier (1byte)	Frame Length (1byte)	Address Code (1byte)	Command (1byte)	Data (3byte)	Checksum (1byte)
0x77	0x07		0x23	DXXYY	

Response command:

Identifier (1byte)	Frame Length (1byte)	Address Code (1byte)	Command (1byte)	Data (1byte)	Checksum (1byte)
0x77	0x05		0x91	00	

Note: D is the axis position in the data field. For example, 0x00 is the X-axis positive axis alarm open delay time, in seconds. 0x02 is the X-axis positive axis alarm open delay time, in seconds. XX is a two-digit integer value and YY is a two-digit value. The other axis data is the same.

For example, 00 05 00 in this example indicates that the alarm on delay time for setting +X axis is 5 seconds.

2.10 Query alarm delay on time Command : 77 05 00 24 00 29

Identifier (1byte)	Frame Length (1byte)	Address Code (1byte)	Command (1byte)	Data (1byte)	Checksum (1byte)
0x77	0x05		0x24	0x00: +X 0x02: -X	

Response command:

Identifier (1byte)	Frame Length (1byte)	Address Code (1byte)	Command (1byte)	Data (3byte)	Checksum (1byte)
0x77	0x07		0x92	DXXYY	

2.11 Set alarm delay off time Command : 77 07 00 23 01 05 00 30

Identifier (1byte)	Frame Length (1byte)	Address Code (1byte)	Command (1byte)	Data (3byte)	Checksum (1byte)
0x77	0x07		0x23	DXXYY	

Response command:

Identifier (1byte)	Frame Length (1byte)	Address Code (1byte)	Command (1byte)	Data (1byte)	Checksum (1byte)
0x77	0x05		0x91	0x00	

Note: D is the axis position in the data field. For example, 0x01 is the X-axis positive axis alarm off delay time in seconds. 0x03 is the X-axis positive axis alarm off delay time, in seconds. XX is a two-digit integer value and YY is a two-digit value. The other axis data is the same.

For example, 00 05 00 in this example indicates that the alarm off delay time for setting +X axis is 5 seconds.

2.12 Query alarm delay off time Command: 77 05 00 24 01 2A

Identifier (1byte)	Frame Length (1byte)	Address Code (1byte)	Command (1byte)	Data (1byte)	Checksum (1byte)
0x77	0x05		0x24	0x01: +X 0x03: -X	

Response command:

Identifier (1byte)	Frame Length (1byte)	Address Code (1byte)	Command (1byte)	Data (3byte)	Checksum (1byte)
0x77	0x07		0x92	DXXYY	

2.13 Save Settings Command : 77 04 00 0A 0E

Identifier (1byte)	Frame Length (1byte)	Address Code (1byte)	Command (1byte)	Data (0byte)	Checksum (1byte)
0x77	0x04		0x0A		

Response command:

Identifier (1byte)	Frame Length (1byte)	Address Code (1byte)	Command (1byte)	Data (1byte)	Checksum (1byte)
0x77	0x05		0x8A	00	

Note: For the previous parameter modification settings, you need to send the save command again. If the save setup command is not sent after the setup is completed, these settings will disappear after power off.

Ordering Information

Product number	Way of communication	Package condition
DIS332-232	RS232	IP67 Package/Metal Connector
DIS332-TTL	TTL	IP67 Package/Metal Connector

Executive standard

- Enterprise Quality System Standard: ISO9001:2008 Standard (Certificate No.:10114Q16846ROS)
- CE certification (certificate number: 3854210814)
- ROHS (certificate number: SO81426003)
- GB/T 191 SJ 20873-2003 General specifications for tiltmeters and spirit levels
- GBT 18459-2001 sensor main static performance index calculation method
- JF 1059-1999 Evaluation and Expression of Measurement Uncertainty
- GBT 14412-2005 mechanical vibration and shock mechanical installation of accelerometer
- General requirements for GJB 450A-2004 equipment reliability
- Quality control of key parts and important parts of GJB 909A
- GJB 899 Reliability Qualification and Acceptance Test
- GJB 150-3A high temperature test
- GJB 150-4A low temperature test
- GJB 150-8A rain test
- GJB 150-12A dust test
- GJB 150-16A vibration test
- GJB 150-18A impact test
- GJB 150-23A Tilt and Swing Test
- GB/T 17626-3A RF electromagnetic radiation immunity test
- GB/T 17626-5A surge (hit) impulse immunity test
- GB/T 17626-8A power frequency magnetic field immunity test
- GB/T 17626-11A voltage dips, short interruptions and voltage changes immunity

DIS332

Relay Single-Axis
Inclination Switch

Wuxi Bewis Sensing Technology LLC

Address: Building 30, No. 58 Xiuxi Road, Binhu District, Wuxi City

Hotline: 400-618-0510

Tel: +86 510 85737178-801

Email: sales@bwsensing.com

Website: www.bwsensing.com