



# **GI3400 Series**

**High-precision fiber optic  
integrated navigation system**

# **Technical Manual**

V3.0



## Introduction

BW-GI3400 is a high-performance and high-precision fiber-optic integrated navigation system developed by BWSENSING for aviation surveying and mapping, unmanned aerial vehicles, sea-based and road-based fields. Built-in three-axis fiber optic gyroscope, three-axis accelerometer, optional three-axis magnetic sensor, high-precision air pressure sensor, including a BD/GPS/GLONASS three-mode receiver. It can measure the speed, position, and attitude of the carrier, and output the compensated angular rate, acceleration, magnetic field, air pressure, temperature and other information.

BW-GI3400 is equipped with a brand-new integrated navigation sensor fusion algorithm engine, optimized for multi-path interference, which can well meet the needs of long-term, high-precision, and high-reliability navigation applications in urban and field complex environments. The product supports multiple external sensors such as GNSS/odometer/DVL/barometric altimeter, and has excellent scalability. By using multi-sensor data fusion technology to combine inertial measurement with satellite navigation, odometer information and other information, the system can be regional adaptability and robustness have been greatly improved.

BW-GI3400 integrated navigation system uses tight coupling technology to closely combine high-precision, professional-grade, multi-channel, dual-antenna single-frequency carrier phase and pseudo-range GPS receivers with high-precision optical fiber inertial measurement units. It has small size, light weight, and Features such as high performance.

## Application

- Optoelectronic pod, the stability of the antenna system
- Attitude/azimuth reference system, multi-beam attitude sensing
- Railroad track inspection vehicle, UAV, unmanned ship navigation and control
- Space stable platform, intelligent navigation and control of coal excavator and mining excavator



## Performance index

External GPS effective 4m baseline	North Seeking Accuracy(deg)	$\leq 0.25 * \text{Secant Latitude}$
	Azimuth Accuracy(deg)	$\leq 0.05$
	Attitude angle Accuracy(deg)	$\leq 0.01$
	Speed Accuracy(m/s)	$\leq 0.03$
	Position Accuracy(m)	$\leq 2\text{m}/\text{RTK } 2\text{cm}$
GPS outages	Azimuth Keeping Accuracy(deg)	$\leq 0.05, 1\text{h}$
	Attitude angle maintaining	$\leq 0.01, 1\text{h}$
	Position accuracy(km)	$\leq 12, 0.5\text{h}$ $\leq 0.05, 5\text{min}$
System measurement range	Azimuth measurement range(deg)	$\pm 180$
	Attitude measurement range(deg)	$\pm 90$
Gyro	Measurement range ( deg/s)	$\pm 600$
	Bias stability ( $^{\circ}/\text{h}$ )	$\leq 0.05$
	Bias repeatability ( $^{\circ}/\text{h}$ )	$\leq 0.05$
	Random walk coefficient ( $^{\circ}/\sqrt{\text{h}}$ )	$\leq 0.005$
	Scale factor Non-linearity (ppm)	$\leq 50$
	Scale factor asymmetry (ppm)	$\leq 50$
	Scale factor repeatability (ppm)	$\leq 50$
Accelerometer	Measurement range (g)	$\pm 30$
	Offset stability (mg)	0.03
	Bias repeatability (mg)	0.03
	Scale factor repeatability (ppm)	$\leq 100$
Environmental parameters	Operating temperature ( $^{\circ}\text{C}$ )	-40 ~ +65
	Storage temperature ( $^{\circ}\text{C}$ )	-50 ~ +80
	Vibration (Hz, $\text{g}^2/\text{Hz}$ )	20 ~ 500, 0.06
	Shock (g, ms)	30, 11
Electrical parameters	Input voltage (Vdc)	+18 ~ +36
	Power (W)	20
	Data output format	RS-422/RS-232/PPS/CAN/RJ45
	Data refresh rate (Hz)	100
Mechanical	Size (mm)	$\leq 191 \times 179 \times 126.5$
	Weight (kg)	5
	Connector	J30JA1-31TJ/Y11P-1210ZK

## Technical index



### Product Size

Product Size: L191mm×W179 mm ×H126.5 (mm)

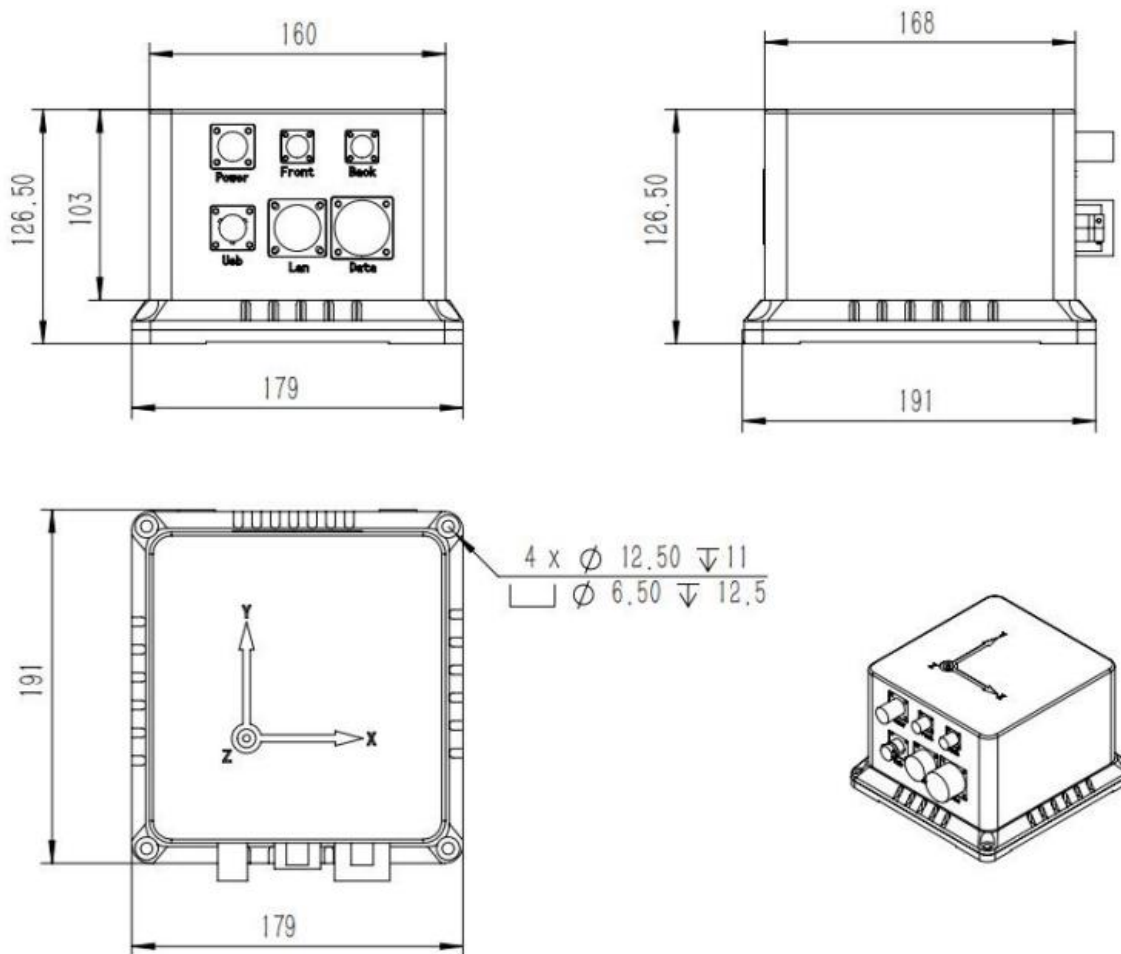

Note: NO dimension tolerance is specified according to grade C of GB/T1804-2000.

## Installation

The GPS antenna we routinely select is a zero-phase measurement one, and general navigation antennas cannot be used in this product. Although some navigation antennas can also be directional, the accuracy will be greatly reduced and errors may also result. If the user replaces an antenna that is not configured or designated by the company, the system will not work properly or other consequences will occur, and the company is not responsible for this.

The correct installation method can avoid measurement errors. The integrated navigation system uses CNC grinding to machine the bottom surface and the measuring surface to make an absolutely smooth surface for easy installation. The following points should be done during installation:



First of all, you must ensure that your equipment has two absolutely smooth planes, and the two planes are absolutely perpendicular, and coincide with the body coordinate system as much as possible to reduce installation errors.

Secondly, while installing the product, the bottom surface of the integrated navigation system coincides with the bottom surface of the aircraft body. Gently push the integrated navigation system to make the combined navigation system and the aircraft surface overlap to ensure that the two surfaces are in close contact with each other. The angle shown is generated, and the correct installation method is shown in Figure B and Figure D.

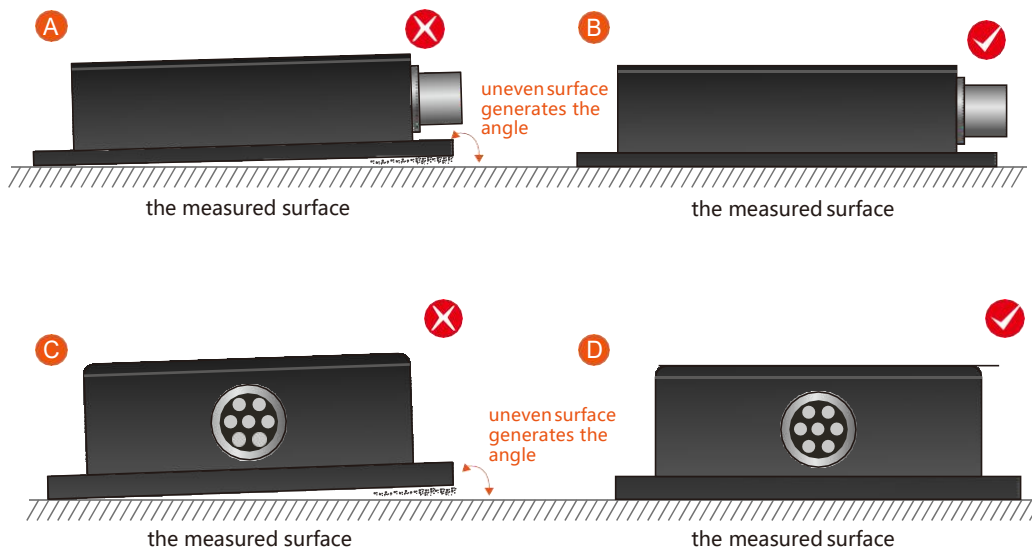

Finally, after the integrated navigation system is closely attached to the body, use screws to ensure tight fixation, smooth contact, stable rotation, and avoid measurement errors due to acceleration and vibration. Remember that at this time, the screw only serves as a fixing function, not a positioning function. The screw hole of the integrated navigation system is processed into an oval shape for easy adjustment.

## Electrical connection

Data cable RS422 interface definition, DB9 female:

DB9 Connector pin	Interface Definition	Remark
1	R+	Receive positive
2	R-	Receive negative
3	T+	Send positive
4	T-	Send negative

## Debugging software

### Steps for usage:

- ① Ensure that the inertial navigation is absolutely stationary, correctly connect the serial port hardware of the integrated navigation, and connect the power supply.
- ② Select computer serial port and baud rate, next click connects serial port.
- ③ Enter the correct geographic latitude, click Inertial Navigation Start → Command Enter, and the working state on the screen shows static alignment. After the working state becomes INS navigation, the inertial navigation enters the working state and can be used at this time.

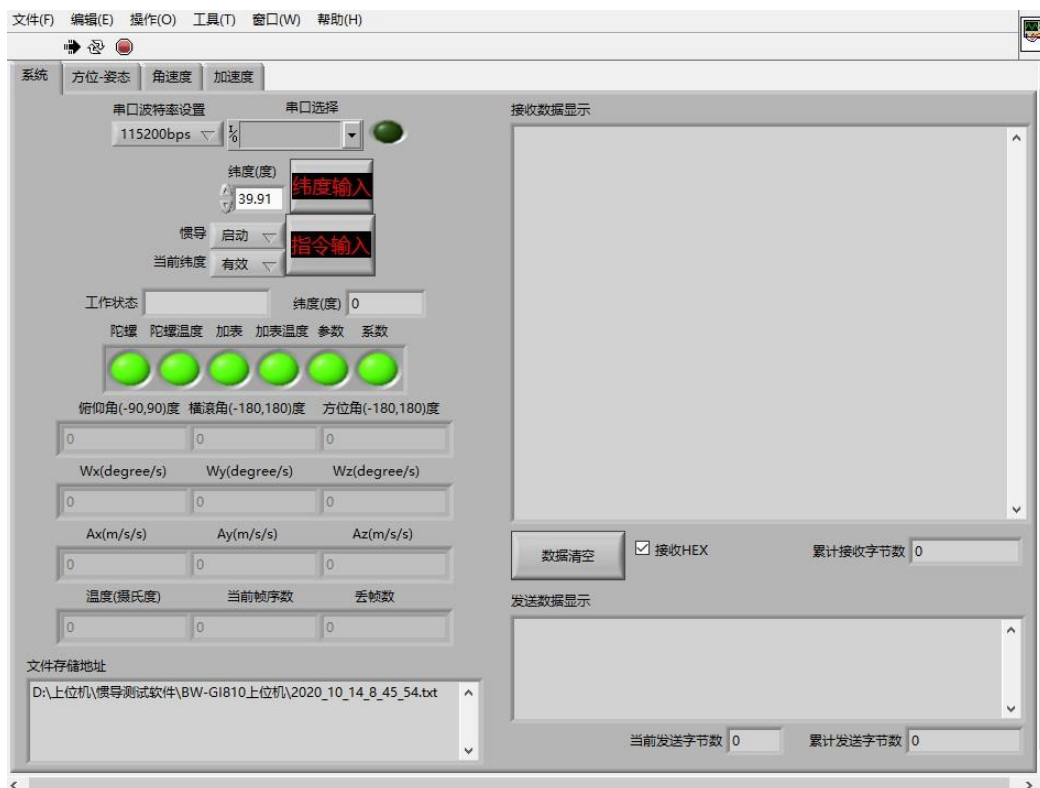

## Protocol

After the system works, it broadcast navigation data to the outside during normal operation on 100Hz Frequency and RS422 communication 115200bps, n, 8, 1, 48 bytes of data per frame is shown in the following table:

Navigation Data			
Byte No.	Content	Type of data	Number of Byte
1-2	Fra header: 0X5A 0X A5	Byte	2
3	Working data: 0- monitor status, 1-Static alignment, 2-INS navigation	Byte	1
4-5	Inertial navigation pitch ([-90 , 90]°) , Unit 0.01°	short int (Low byte first, High byte last)	2
6-7	Inertial navigation roll ([-180 , 180]°) , Unit 0.01°		2
8-9	Inertial navigation azimuth([-180 , 180]°) , <b>North to east is negative, north to west is positive</b> , Unit 0.01°		2
10-11	Inertial navigation X axis angular rate Wx(degree/s), unit 0.01 deg/ s		2
12-13	Inertial navigation Y axis angular rate Wy (degree/s), unit 0.01 deg/ s		2
14-15	Inertial navigation Z axis angular rate Wz(degree/s), unit 0.01 deg/ s		2
16-17	Inertial navigation X axis acceleration Ax (m/s/s), unit 0.01 m/s/s		2
18-19	Inertial navigation Y axis acceleration Ay (m/s/s), unit 0.01 m/s/s		2
20-21	Inertial navigation Z axis acceleration Az (m/s/s), unit 0.01 m/s/s		2
22-23	Speed after GPS satellite positioning, unit 0.1 m/s		2
24-25	GPS Track angle([-180 , 180]°) , <b>North to east is negative, north to west is positive</b> , Unit0.1°		2
26-27	GPS Number of satellites		2
28-29	GPS altitude, Unit 0.1m	2	



30-33	GPS Latitude after satellite positioning, Unit degree	float (Low byte first, High byte last) , Ranges[-90,90] ° , The north latitude is positive and the south latitude is negative.	4
34-37	Longitude after GPS satellite positioning, unit degree	float (Low byte first, High byte last), Ranges [-180,180]°, The east longitude is positive and the west longitude is negative.	4
38-41	GPS UTC date (ddmmyy day month year)	float (Low byte first, High byte last)	4
42-45	UTC time (hhmmss hour, minute, second format)		4
46	Sending sequence number (0-255 cyclically increasing)	Byte	1
47	Check byte, cumulative sum of bytes 3 to 46		1
48	End of frame: 0X55		1



## Executive standard

- Enterprise Quality System Standard: ISO9001:2015 Standard (Certificate No.064-21-Q-3290-RO-S)
- CE certification (certificate number: M.2019.103. U Y1151)
- ROHS (certificate Number: G 190930099)
- GB/T 191 SJ 20873-2003 General specification for inclinometer and level
- GBT 18459-2001 The calculation method of the main static performance index of the sensor
- JJF 1059-1999 Evaluation and expression of measurement uncertainty
- GBT 14412-2005 Mechanical vibration and shock Mechanical installation of accelerometer
- GJB 450A-2004 General requirements for equipment reliability
- GJB 909A Quality control of key parts and important parts
- GJB899 Reliability appraisal and acceptance test
- GJB150-3A High temperature test
- GJB150-4A Low temperature test
- GJB150-8A Rain test
- GJB150-12A Sand and dust experiment
- GJB150-16A Vibration test
- GJB150-18A Impact test
- GJB150-23A Tilt and rock test
- GB/T 17626-3A Radio frequency electromagnetic field radiation immunity test
- GB/T 17626-5A Surge (impact) immunity test
- GB/T 17626-8A Power frequency magnetic field immunity test
- GB/T 17626-11A Immunity to voltage dips, short-term interruptions and voltage changes
- GB/T 2423.22-2012 Environment test  
The Second Part: Test Method Test N: Temperature change (IEC60068-2-14:2009,IDT)
- GB/T 10125-2012 Artificial atmosphere corrosion test Salt spray test (ISO 9227:2006,IDT)

# **GI3400 Series**

## **High-precision fiber optic integrated navigation system**

### **Wuxi Bewis Sensing Technology LLC**

Add: Building 30, NO. 58, Xiuxi Road, Binhu District,  
Wuxi Jiangsu China

Tel: +86 18921292620

Mail: [sales@bwsensing.com](mailto:sales@bwsensing.com)

Web: [www.bwsensing.com](http://www.bwsensing.com)