



IMU1400 Series

Fiber optic gyro Inertial
measurement unit

Technical Manual



Introduction

BW-IMU1400 is a fiber optic gyro inertial measurement unit with high reliability, which can measure the angular velocity and acceleration velocity of the moving carrier. The acceleration and angular velocity deviations are estimated by a 6-state Kalman filter with appropriate gain, even in extremely complex applications and dynamics environment, the product can also reliably detect and conduct multiple degrees of freedom. So it is suitable for inertial attitude measurement in motion or vibration.

BW-IMU1400 uses highly reliable MEMS accelerometers and gyroscopes, and ensure measurement accuracy through algorithms, meanwhile, the seal design and strict process ensure that the dynamic parameters of the carrier such as the angular velocity, acceleration and attitude can be accurately measured under harsh conditions. Through various compensations such as nonlinear compensation, quadrature compensation and drift compensation, the error source of BW-IMU1400 can be greatly eliminated, and the product accuracy level can be improved. The BW-IMU1400 is equipped with digital interface that can be easily integrated into the user's system.

产品特点

- High sampling frequency
- Temperature compensation, the unique calibration techniques and methods
- Small size, L178×W184×H229.5mm
- Special bias tracking algorithm eliminates drift
- Gyro bias stability $\leq 0.05^\circ / h$
- Wide measurement range, $\pm 600 \text{ deg / s}$

应用领域

- Unmanned vehicle
- Aeroplane mapping
- Satellite antenna
- Manless driving
- Photoelectric detection stabilization
- Attitude / heading reference system

Specifications

Electrical Specifications

Input voltage	9-36V DC
Power	20W
Data output	RS 422

Performance Specifications

Gyro performance parameters	Measuring range (°/s)	-600~+600
	Bias stability (°/h)	≤0.05
	Bias repeatability (°/h)	≤0.05
	Random walk (°/√hr)	≤0.005
	Scale factor nonlinearity (ppm)	≤100
	Scale factor asymmetry (ppm)	≤100
	Scale factor repeatability (ppm)	≤100
Accelerometer performance parameters	Measuring range (g)	±10
	Bias stability (mg)	0.05
	Bias repeatability (mg)	0.05
	Scale factor repeatability (ppm)	≤100
Environmental parameters	Operating temperature (°C)	-40 ~ +65
	Storage temperature (°C)	-45 ~ +70
	Vibration (Hz, g2/Hz)	20 ~ 2000,0.06
	Shock (g, ms)	30,11
Electrical parameters	Input voltage (Vdc)	+9~+36
	Power (W)	20
	Data output	RS-422
Physical parameter	Size (mm)	≤178×184×229.5
	Weight (kg)	7
	Connector	J30JA1-31TJ/Y11P-1210ZK10

Product Size

Product Size: L178×W184×H229.5 (mm)

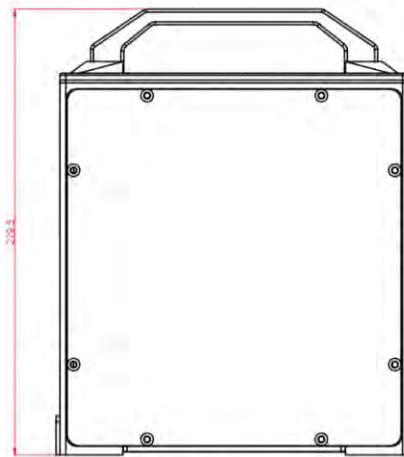
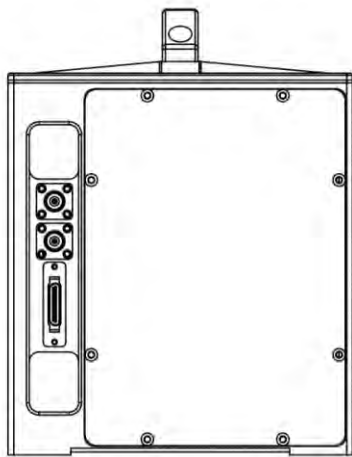
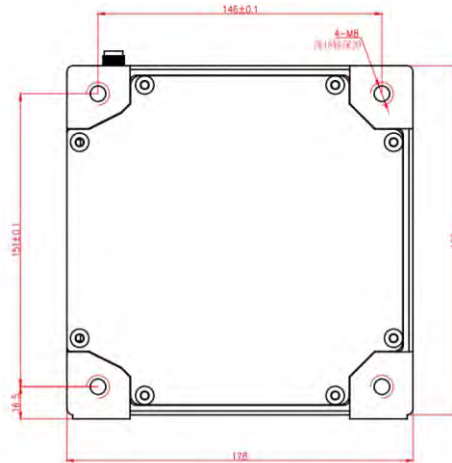

Note: Unfilled dimensional tolerances are performed in accordance with GB/T1804-2000 Class C.

Product installation

The correct installation method can avoid measurement error. The inertial measurement unit produces an absolutely smooth surface by grinding on the underside and measuring surface for installation. The following points should be made when installing the sensor:

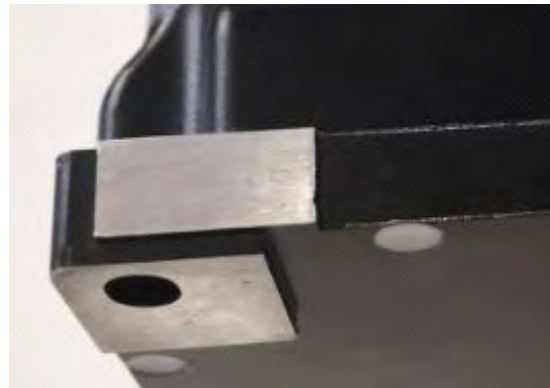

First of all, to ensure that the sensor mounting surface and the measured surface completely close, the measured surface should be as horizontal as possible, so that we can reduce installation error. Secondly, when the product is installed, the bottom surface of the IMU and the body should be coincident, and it is gently pushed to make the measurement surface of the IMU coincide with that of the machine body, so that both surfaces are tightly attached, and there is no angle in Fig.A and Fig.C. The correct installation is shown in Fig.B and Fig.D.

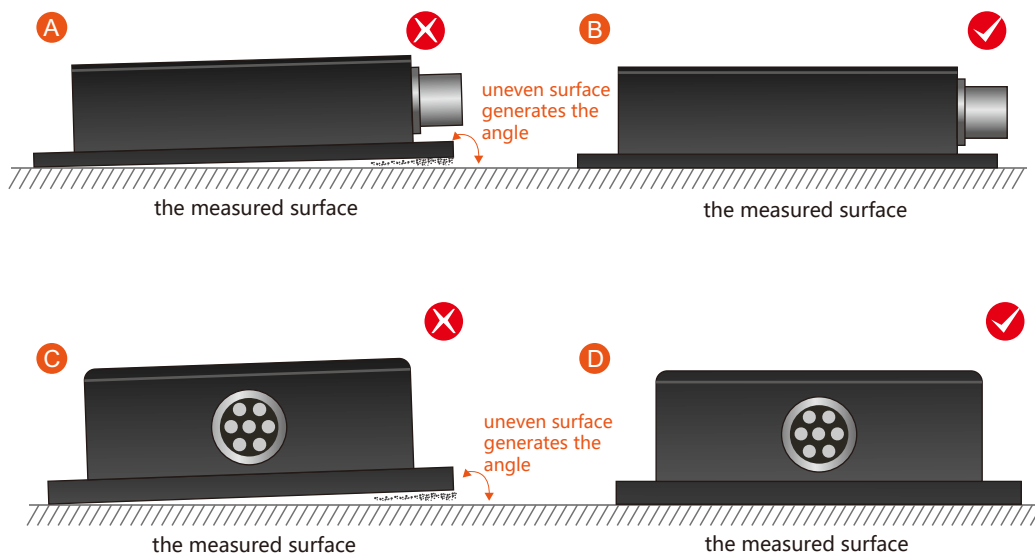

Finally, after the product is tightly attached, screws should be used to fix the IMU to ensure tight fixation, smooth conduct and stable rotation. Measurement errors caused by acceleration and vibration should be voided. Bear in mind that the screw only plays a fixed role and does not have a positioning function. The screw hole of the IMU is processed into an elliptical shape for easy adjustment.

Executive standard

- Enterprise Quality System Standard: ISO9001:2008 Standard(Certificate No.:10114Q16846ROS)
- CE certification (certificate number: 3854210814)
- ROHS (certificate number: SO81426003)
- GJB 2426A-2004 Fiber Optic Gyro Test Method
- GBT 18459-2001 sensor main static performance index calculation method
- JF 1059-1999 Evaluation and Expression of Measurement Uncertainty
- GBT 14412-2005 mechanical vibration and shock mechanical installation of accelerometer
- General requirements for GJB 450A-2004 equipment reliability
- Quality control of key parts and important parts of GJB 909A
- GJB 899 Reliability Qualification and Acceptance Test
- GJB 150-3A high temperature test
- GJB 150-4A low temperature test
- GJB 150-8A rain test
- GJB 150-12A dust test
- GJB 150-16A vibration test
- GJB 150-18A impact test
- GJB 150-23A Tilt and Swing Test
- GB/T 17626-3A RF electromagnetic radiation immunity test
- GB/T 17626-5A surge (hit) impulse immunity test
- GB/T 17626-8A power frequency magnetic field immunity test
- GB/T 17626-11A voltage dips, short interruptions and voltage changes immunity
- GB/T 2423.22-2012 Environmental testing Part 2:test method Test N:temperature change (IEC 60068-2-14:2009,IDT)
- GB/T 10125-2012Artificial atmosphere corrosion test Salt spray test (ISO 9227:2006,IDT)

IMU1400

Fiber optic gyro Inertial
measurement unit

Wuxi Bewis Sensing Technology LLC

Address: Building 30, No. 58 Xiuxi Road, Binhu District, Wuxi City

Hotline: 400-618-0510

Tel: +86 510 85737178-801

Email: sales@bwsensing.com

Website: www.bwsensing.com