



BW-IMU500C Series

High-performance

Inertial Measurement Unit

Technical Manual



Introduction

BW-IMU500C is a high-precision inertial measurement unit that can measure the angular velocity and acceleration of a moving carrier. The data deviation is estimated by the 6-state Kalman filter with appropriate gain, which is suitable for inertial attitude measurement in motion or vibration state.

BW-IMU500C uses highly reliable MEMS accelerometers and gyroscopes, and it uses algorithms to ensure measurement accuracy. At the same time, the sealing design and strict production process ensure that the product can accurately measure movement parameters such as the angular velocity, acceleration and attitude of the carrier in harsh environments. Through various compensations such as nonlinear compensation, quadrature compensation, temperature compensation and drift compensation, the error source of BW-IMU500C can be greatly eliminated and the product accuracy level can be improved. It has a digital interface, which can be easily integrated into the user's system.

Feature

- Dynamic compensation, quadrature compensation
- Sampling frequency up to 500Hz
- RS232 /485/TTL Output optional
- Wide temperature range: $-40^{\circ}\text{C}\sim+85^{\circ}\text{C}$, Temperature compensation
- Small size: $L60\times W59\times H29\text{mm}$

Application

- Unmanned ships and underwater robots
- Construction machinery
- Stable platform
- AGV unmanned guided vehicle
- Heavy duty truck
- Unmanned drive
- Robots
- Unmanned aircrafts

Product Feature



Electrical index

Power supply	9-36V DC
Working current	30mA (40mA max)
Operating temperature	-40~85°C
Storage temperature	-55~100°C



Performance index

Gyro	Resolution	0.01°/sec
	Range	±400°/sec
	Bias stability at room temperature	< 0.5°/h (100s,1σ) < 5°/h (10s,1σ)
	Bias stability at full temperature	< 20°/h (10s, 1σ)
	Angle random walk coefficient	< 0.1 °/√h
	Bias repeatability	< 50 °/h (1σ)
	Scale factor non-linearity	≤100ppm (1σ)
	Scale factor repeatability	≤100ppm (1σ)
	Bandwidth	100Hz
Accelerometer	Range: X, Y, Z	±3.6g
	Resolution	0.01mg
	Bias stability	0.001mg (25°C, 100s, 1σ) 0.01mg (25°C, 10s, 1σ)

Resolution: The smallest change value of the measured value that the sensor can detect and distinguish within the measurement range.



Mechanical Index

Connector	Metal joint (Cable 1.5m)
Protection level	IP67
Shell material	Magnesium aluminum alloy anodizing
Installation	Four M4 screws



Package product size

Product size: L60*W59*H29 (mm)

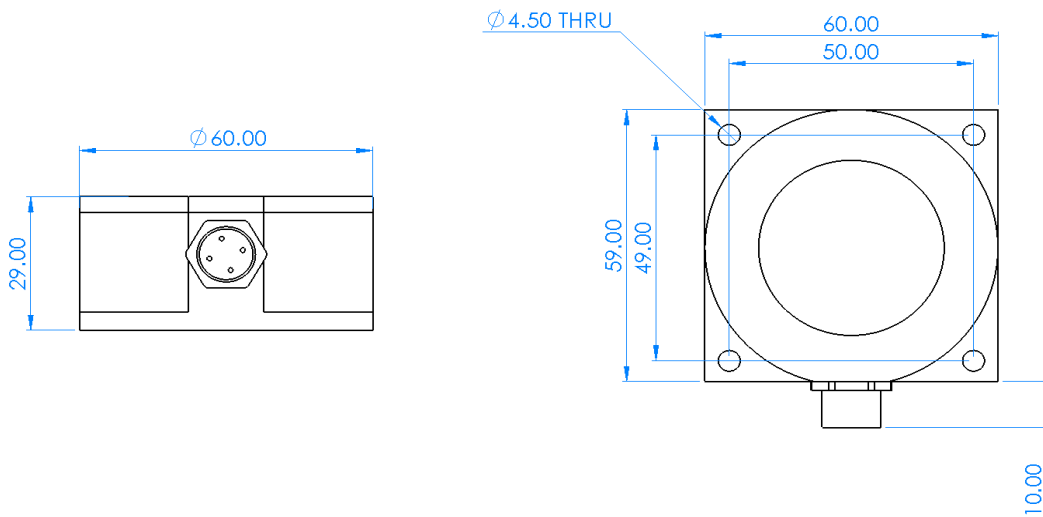

PCB size



Product size: L44*W35*H11 (mm) The length and width may have an error of ± 1 mm, please refer to the actual product

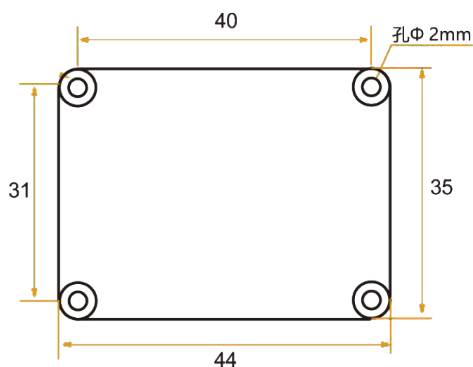

Installation

The correct installation method can avoid measurement errors. When installing the sensor, please do the following:

First of all, make sure that the sensor mounting surface is completely close to the measured surface, and the measured surface should be as level as possible, and there should be no included angles as shown in Figure A and Figure C. The correct installation method is shown in Figure B and Figure D.

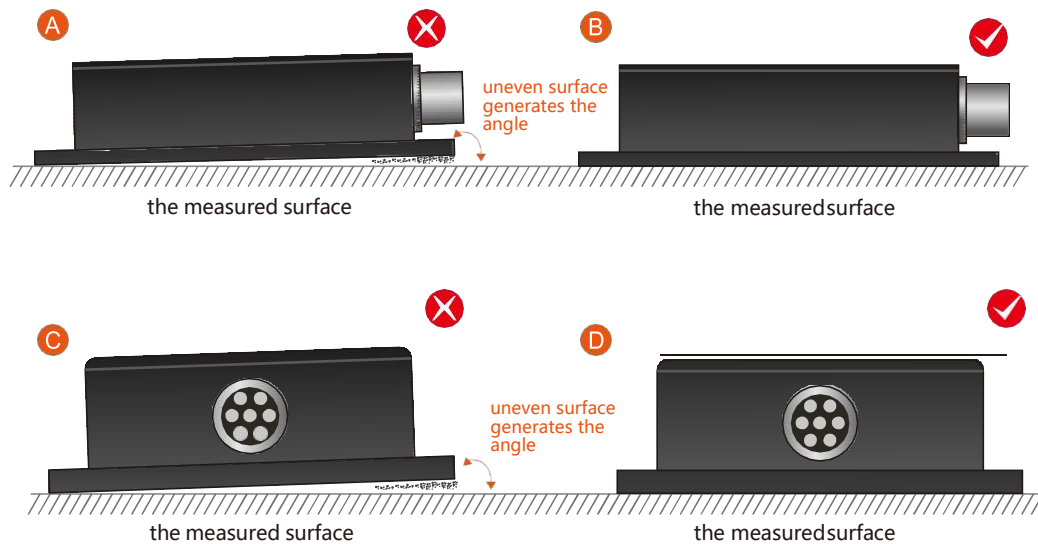

Secondly, the bottom line of the sensor and the axis of the measured object cannot have an angle as shown in Figure E. When installing, keep the bottom line of the sensor parallel or orthogonal to the axis of rotation of the measured object. This product can be installed horizontally or vertically (vertical installation needs to be customized), and the correct installation method is shown in Figure F.

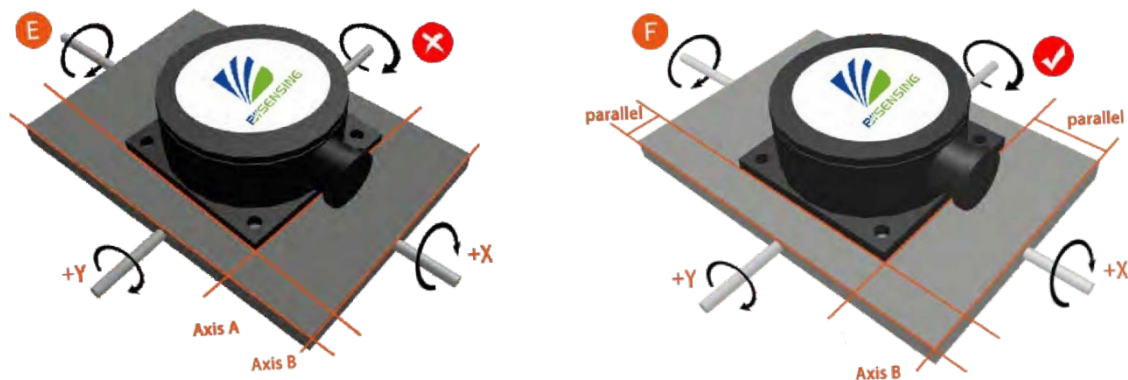

Finally, the mounting surface of the sensor and the surface to be measured must be tightly fixed, smooth in contact, and stable in rotation, and measurement errors due to acceleration and vibration must be avoided.

Electrical Connection

Wiring Definition

	RED	BLUE	BLACK	GREEN	YELLOW
Wiring color	1	2	3	4	5
function	Power Positive DC 9-36V	NC	GND	Receive RXD B、D-	Send TXD A、D+

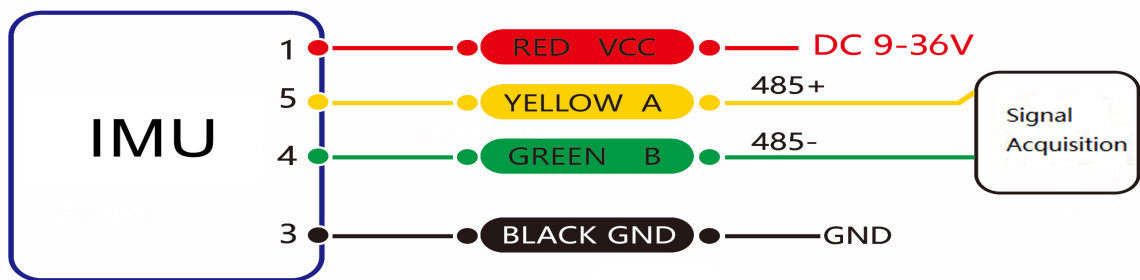

RS 485 connection diagram

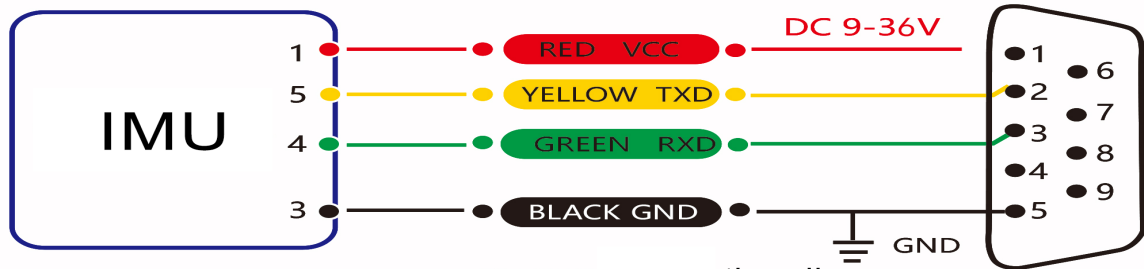

RS 232 connection diagram

Axial Definition

Three-axis attitude, gyroscope, acceleration data axis

Both obey the right-hand rule.



Debugging software

You can download the serial debugging assistant directly on the official website (Technical service -> download area), or you can use the more convenient and intuitive host computer software.

BW-IMU500C supporting serial port debugging software can connect the inclination sensor on the computer to display the angle. The software debugging interface is shown in the figure below. Using the tilt angle to debug the host computer, you can easily display the current X and Y directions, and you can also modify and set other parameters.

Steps for use:

- ① Connect the serial port hardware of the inclinometer correctly, and connect the power supply.
- ② Select correct device model. (Select azimuth series.)
- ③ Select computer serial port and baud rate and click connect serial port.
- ④ Click start button and the current inclination angle of the incliner in X and Y directions will be displayed on the screen.



Order information

Product model	Communication mode	Package situation
BW-IMU500C-485	RS485	IP67 Package /Metal joint
BW-IMU500C -232	RS232	IP67 Package /Metal joint
BW-IMU500C -TTL	TTL	IP67 Package /Metal joint

Executive standard

- National Standard for Static Calibration of Biaxial Inclination Sensors (Draft)
- GB/T 191 SJ 20873-2003 General Specification for Tiltmeters and Leveling Devices

BW-IMU500C Series

High-precision Inertial Measurement Unit

Wuxi Bewis Sensing Technology LLC

Add: Building 30, No.58 Xiuxi Road, Binhu District,
Wuxi City, Jiangsu Province, China

Tel: +86 18921292620

Email: sales@bwsensing.com

Web: www.bwsensing.com