

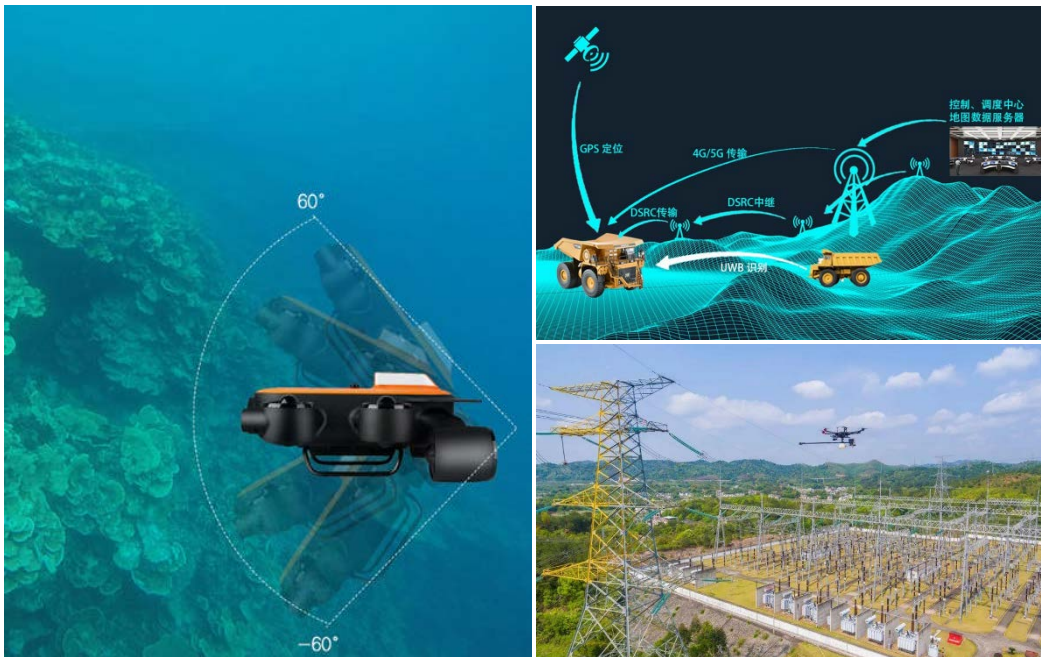

BW-IMU810 Series

**Ultra-small Three-axis Fiber Optic
Gyroscope Inertial Measurement Unit**

Technical Manual



Introduction

BW-IMU810 is a small-sized high-precision three-axis fiber optic gyroscope inertial measurement unit developed and produced by Bewis. It can output acceleration and angular velocity information without relying on external signal input, which can be calculated through user-developed algorithms. The azimuth angle, roll angle, pitch angle, Euler angle, and quaternion information of the measured carrier are suitable for inertial attitude measurement under various states of motion, vibration or static.

BW-IMU810 uses a highly reliable MEMS accelerometer and a three-axis fiber optic gyroscope. The original data deviation is estimated by the 6-state Kalman filter with appropriate gain, and the measurement accuracy is ensured by the algorithm. The parameters are nonlinearly compensated and orthogonal. Various compensations such as compensation, temperature compensation and drift compensation can greatly eliminate errors and improve the accuracy of the product. This product has a digital interface, which can be easily integrated into the system.

Feature

- Gyro bias stability: $\leq 0.08^\circ/h$
- Measuring range: $\pm 300^\circ/s$
- Acceleration range: $\pm 30g$
- Wide temperature range: $-40^\circ C \sim +75^\circ C$
- Power Supply: 12~24V
- Small Dimension: L97.3*W90*H70mm

Application

- Unmanned boats and underwater vehicles
- AI Handling Robot
- Stable precision optical platform
- Large Ship
- AGV
- Unmanned drive and special vehicles
- Geographic Information Surveying and Mapping
- Unmanned Aircraft

Specification



Performance Indicators

Fiber optic gyroscope	Bias stability (10s, 1 σ) (°/h)	$\leq 0.08^\circ/\text{h}$
	Bias repeatability (1 σ) (°/h)	$\leq 0.08^\circ/\text{h}$
	Bias stability at full (100s, 1 σ , -40~+60°C)	$\leq 0.09^\circ/\text{h}$
	Scale factor nonlinearity (1 σ)	$\leq 120\text{ppm}$
	Scale factor repeatability	$\leq 120\text{ppm}$
	Measuring range	$\pm 300^\circ/\text{s}$
	Random walk coefficient	$\leq 0.08^\circ/\text{h}^{1/2}$
	bandwidth	$\geq 400\text{Hz}$
Accelerometer	Bias stability at room (10s, 1 σ)	$\leq 0.6\text{mg}$
	Bias repeatability at room	$\leq 0.6\text{mg}$
	Bias stability at full (10s, 1 σ)	$\leq 1\text{mg}$
	Bias repeatability at full	$\leq 1\text{mg}$
	Scale factor nonlinearity (1 σ)	$\leq 300\text{ppm}$
	Scale factor repeatability (1 σ)	$\leq 300\text{ppm}$
	Range	$\pm 30\text{g}$
Other indicators	Operating temperature	-40~+60°C
	Storage Temperature	-45~+75°C
	Dimension	97.3×90×70mm
	Start time	$\leq 1\text{min}$
	Weight	1000g

Electrical Indicators

Power Input	+12~+24V
Power ripple (Vpp)	≤50mV
Maximum power consumption	< 9W

Package Size

Product Size: L97.3*W90*H70 (mm)

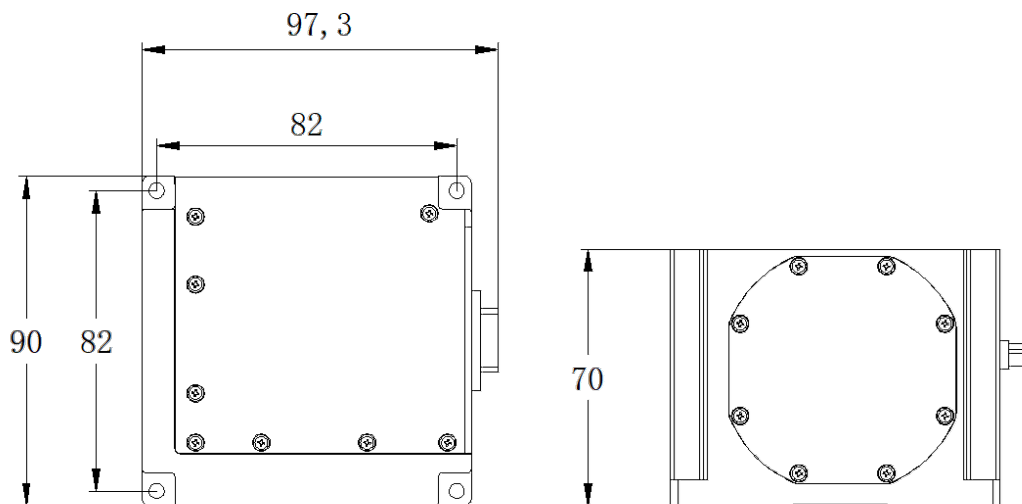

Installation

The correct installation method can avoid measurement errors. When installing the sensor,

please do the following:

First of all, ensure that the sensor mounting surface is completely close to the surface to be measured. The surface to be measured should be as level as possible, and there should be no included angles as shown in Figure A and Figure C. The correct installation method is shown in Figure B and Figure D.

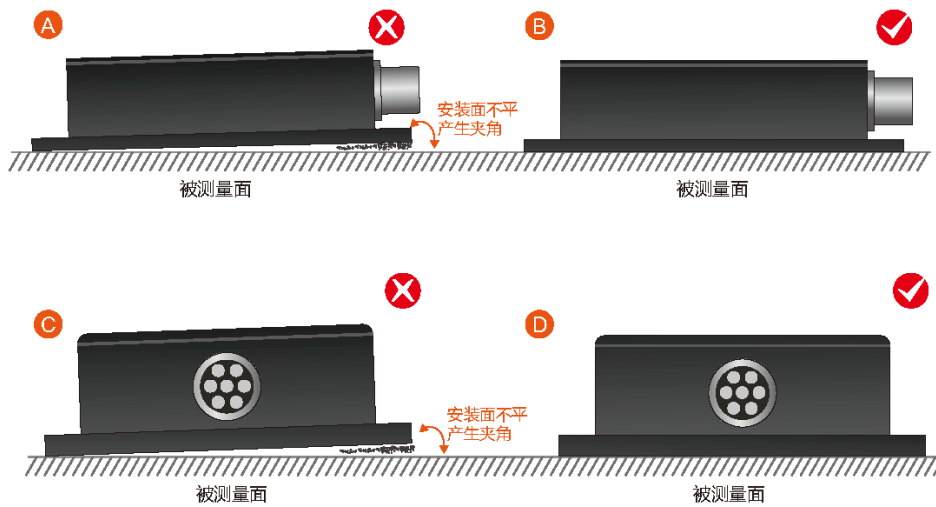

Secondly, the bottom line of the sensor and the axis of the measured object cannot have an angle as shown in Figure E. When installing, keep the bottom line of the sensor parallel or orthogonal to the axis of rotation of the measured object. This product can be installed horizontally or vertically (vertical installation needs to be customized), and the correct installation method is shown in Figure F.

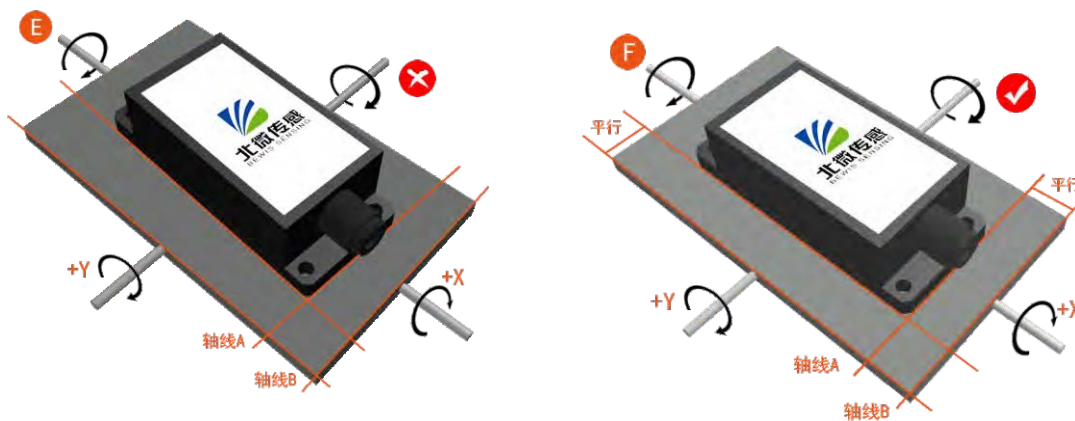

Finally, the mounting surface of the sensor and the surface to be measured must be tightly fixed, smooth in contact, and stable in rotation, and measurement errors due to acceleration and vibration must be avoided.

Connections

Core point number	Definition	Annotation
1	GND_IN	Input
2	VIN	Power input
3	VCC_5V	+5V (0.5A) reserve output power
4	P_GND	Keep output
5	A422_R+	Serial port A inertial terminal receiving positive
6	A422_R-	Serial port A used to receive negative
7	A422_T-	Serial port A used to send negative
8	A422_T+	Serial port A habit group terminal sends positive
9	B422_R+	Serial port B inertial terminal receiving positive
10	B422_R-	Serial port B inertia terminal receives negative
11	B422_T+	Serial port B is used to send positive
12	B422_T-	Serial port B is used to send positive
13-21	Hang in the air	

Note: When connecting or touching the product, anti-static measures should be taken in accordance with the regulations of GJB 1649-1993.

Operating procedures

1、 Check before use

Check the appearance of the product for physical damage such as collisions.

2、 Instructions on how to use the product

- a) The product is installed on the carrier, and the cable is correctly connected as required;
- b) Perform data connection in accordance with the communication protocol.

3、 Matters needing attention

- a) The product should not be frequently switched on and off during use, so as not to damage the performance of the gyro and reduce the service life of the product;
- b) Before powering on the product, check the power supply system to ensure that there is no short circuit between the electrical points of the power supply, and between the product shell and the electrical points;
- c) If there is any abnormal operation of this product, please consult the manufacturer and prohibit unauthorized disassembly and maintenance;
- d) The optical fiber inertial unit is a precision instrument, which should be handled with care during use and transportation;
- e) Must ensure the correct connection of product input and output signal lines and power supply lines;
- f) Anti-static measures are required to be taken during the contact with the product;
- g) The magnetic field strength around the product location is required to be less than 2 Gauss.

Maintenance

- (1) Before the product is loaded into the carrier, it is required to power on the product at least once every 6 months, and the power-on time is 3600s. The power-on time does not require testing the electrical parameters of the product;
- (2) After the product is loaded into the carrier, it is required to be energized at least once a year, and the power-on time is 3600s, and the electrical parameters of the product are not required to be tested when the product is energized;
- (3) The product should be re-calibrated every 8 years (by the production unit).

Troubleshooting

This product is in a sealed state and cannot be repaired on site after any failure of the user, and needs to be returned to the production unit for repair.

The following can only list some possible failure phenomena that are not the product itself. See the table below. If there are other technical problems in the use of the product, please contact the product manufacturer.

No.	Failure phenomenon	Reasons	Elimination method
1	The product is energized, the ammeter indication is basically zero	The product is not powered or the current is too small	Check the power supply and power supply circuit, restore the product power supply
2	The product is powered on, the ammeter indicates normal, but the computer acquisition program does not work	Abnormal test equipment acquisition system	Check the connection cable and
		Software program conflict	Restart the computer

Transport and storage

1、Precautions for transportation

- (1) Place the product in the direction shown in the packaging box;;
- (2) Transportation by road, rail, air and water is allowed;
- (3) Make sure that the packing box is fastened to the carrier and will not move during transportation.

2、Storage conditions, period and precautions

- (1) The products placed in the packaging box should be stored in an air-conditioned warehouse under standard atmospheric pressure, with an ambient temperature of $25^{\circ}\text{C}\pm 10^{\circ}\text{C}$, a relative humidity of 30% to 70%, and the surrounding magnetic field strength less than 2 Gauss;
- (2) The product storage period is 15 years.

Unpacking matters

- (1) Check the appearance of the outer packaging for physical damage such as collisions;
- (2) Check whether the product and supporting accessories are complete, see the table below for details;
- (3) Electrostatic protection treatment should be carried out when taking out the product.

No.	Name	Quantity
1	BW-IMU810 Fiber Inertial Measurement Unit	1
2	Packing box	1
3	Test Report	1
4	J30J-21TJL connector	1
5	Certificate of conformity	1

Executive standard

- National Standard for Static Calibration Specifications for Dual-Axis Inclination Sensors (Draft)
- GB/T 191 SJ 20873-2003 General Specification for Inclinometers and Levels

BW-IMU810 Series

High-precision Fiber Optic

Gyroscope Inertial Measurement Unit

Wuxi Bewis Sensing Technology LLC

Add: Building 30, No.58 Xiuxi Road, Binhu District,
Wuxi City, Jiangsu Province, China

Tel: +86 18921292620

Email: sales@bwsensing.com

Web: www.bwsensing.com