

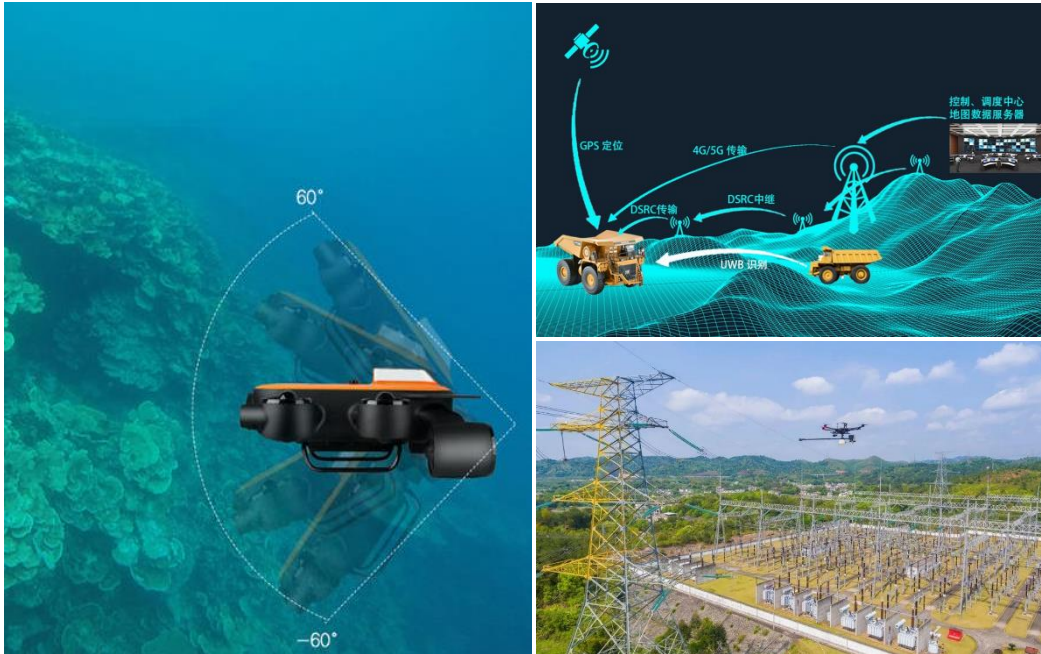

# **BW-IMU910 Series**

**High-Precision Three-axis Fiber optic  
gyroscope Inertial measurement unit**

## **Technical Manual**



## Introduction

BW-IMU910 is a small three-axis fiber optic gyroscope inertial measurement unit developed and produced by Bewis Sensing. It has a built-in high-precision three-axis fiber optic gyroscope and accelerometer. It can output acceleration and angular velocity information without relying on external signal input. The user can calculate the azimuth angle, roll angle, and pitch angle of the measured carrier, which is suitable for inertial measurement in various states of motion, vibration or static.

BW-IMU910 uses a highly reliable MEMS accelerometer and a three-axis fiber optic gyroscope. The original data deviation is estimated by the 6-state Kalman filter with appropriate gain, and the measurement accuracy is ensured by the algorithm. The parameters are compensated by non-linearity and orthogonality. Various compensations such as compensation, temperature compensation and drift compensation can greatly eliminate errors and improve the accuracy of the product. This product has a digital interface, which can be easily integrated into the system.

## Feature

- Bias stability:  $\leq 0.05^\circ/h$
- Measurement Range:  $\pm 300^\circ/s$
- Accelerometer Range:  $\pm 30g$
- Wide temperature range:  $-40^\circ C \sim +75^\circ C$
- Power supply: 12~30V
- Small Dimension: L100 \* W100 \* H100 (mm)

## Application

- Unmanned boats and underwater vehicles
- Intelligent handling robot
- Stable precision optical platform
- Large ship
- AGV
- Unmanned and special vehicles
- Geographic Information Surveying and Mapping
- Unmanned Aircraft

**Specification**

**Performance index**

Gyro	Bias stability (10s, 1 $\sigma$ ) (°/h)	$\leq 0.05^\circ/h$
	Zero offset repeatability (1 $\sigma$ ) (°/h)	$\leq 0.05^\circ/h$
	Bias stability at full temperature (100s, 1 $\sigma$ , -40~+60°C)	$\leq 0.05^\circ/h$
	Scale factor nonlinearity (1 $\sigma$ )	$\leq 100\text{ppm}$
	Scale factor repeatability	$\leq 100\text{ppm}$
	Measuring range	$\pm 300^\circ/s$
	Random walk coefficient	$\leq 0.005^\circ /h^{1/2}$
	Bandwidth	$\geq 400\text{Hz}$
Accelerometer (quartz)	Stability of normal temperature deviation (10s, 1 $\sigma$ )	$\leq 0.1\text{mg}$
	Offset repeatability at room temperature	$\leq 0.1\text{mg}$
	Offset stability at full temperature (10s, 1 $\sigma$ )	$\leq 0.2\text{mg}$
	Offset repeatability at full temperature	$\leq 0.2\text{mg}$
	Scale factor non-linearity (1 $\sigma$ )	$\leq 100\text{ppm}$
	Scale factor repeatability (1 $\sigma$ )	$\leq 100\text{ppm}$
	Range	$\pm 30\text{g}$
Other index	Operating temperature	-40~+60°C
	Storage temperature	-45~+85°C
	Dimension	100×100×100mm
	Start Time	$\leq 1\text{min}$
	Weight	2000g

 **Electrical index**

Power input	+12~+30V
Power ripple (Vpp)	≤50mV
Maximum power consumption	< 9W

 **Package Product Size**

Product size: L100\*W100\*H100 (mm)

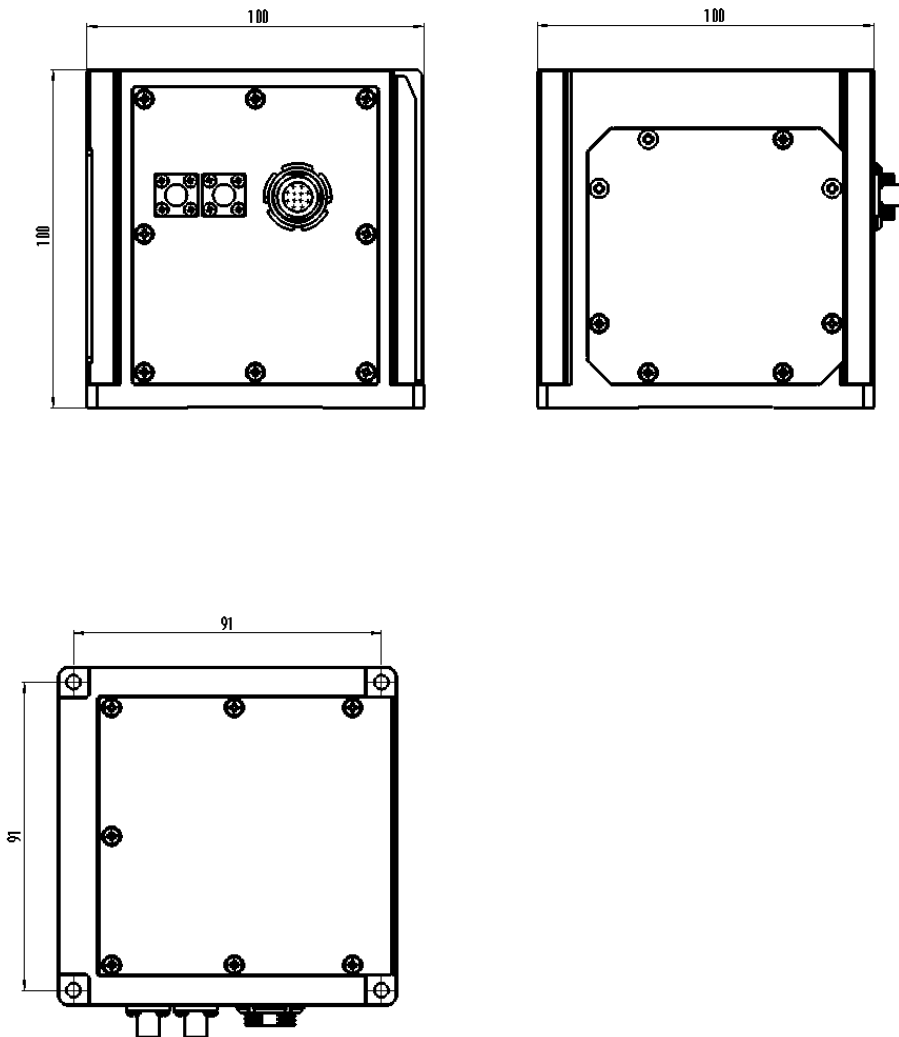

## Installation

The correct installation method can avoid measurement errors. When installing the sensor, please do the following:

First of all, make sure that the sensor mounting surface is completely close to the measured surface, and the measured surface should be as level as possible, and there should be no included angles as shown in Figure A and Figure C. The correct installation method is shown in Figure B and Figure D

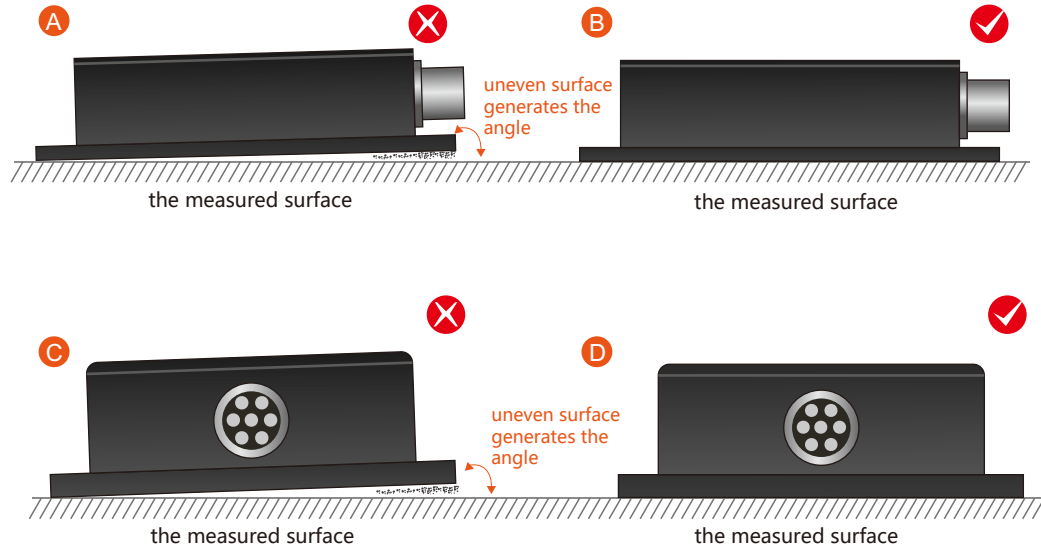

Secondly, the bottom line of the sensor and the axis of the measured object cannot have an angle as shown in Figure E. When installing, keep the bottom line of the sensor parallel or orthogonal to the axis of rotation of the measured object. This product can be installed horizontally or vertically (vertical installation needs to be customized), and the correct installation method is shown in Figure F.

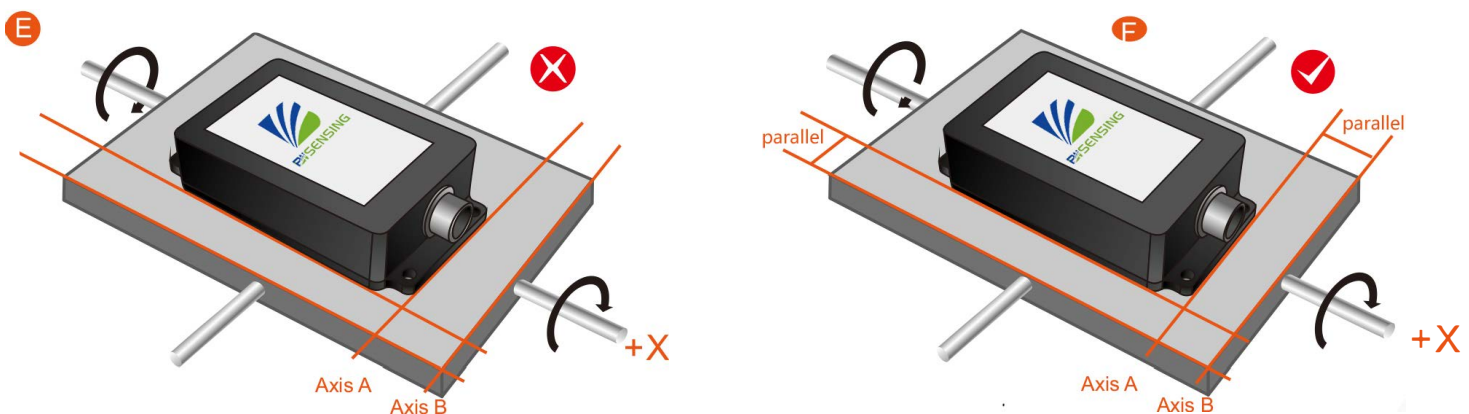

Finally, the mounting surface of the sensor and the surface to be measured must be tightly fixed, smooth in contact, and stable in rotation, and measurement errors due to acceleration and vibration must be avoided.

## Connections

Core point number	Definition	Annotation
1	GND_IN	Input
2	VIN	Power input
3	VCC_5V	+5V (0.5A) Reserve output power
4	P_GND	Keep output
5	A422_R+	Serial port A inertial terminal receiving positive
6	A422_R-	Serial port A used to receive negative
7	A422_T-	Serial port A used to send negative
8	A422_T+	The serial port A custom terminal sends positive
9	B422_R+	Serial port B inertial terminal receiving positive
10	B422_R-	Serial port B inertial group terminal receives
11	B422_T+	Serial port B used to send positive
12	B422_T-	Serial port B used to send negative
13-21	Hang in the air	

Note: When connecting or touching the product, anti-static measures should be taken in accordance with the regulations of GJB 1649-1993.

## Operating procedures

### 1. Check before use

Check the appearance of the product for physical damage such as collisions.

### 2. Instructions on how to use the product

(1) The product is installed on the carrier, and the cable is correctly connected according to the requirements of Table 3;

(2) Carry out data connection according to the communication protocol of 2.6.3.

### 3. Attentions

(1) IMU should not perform frequent power-on and power-off operations during use, so as not to damage product performance and reduce product service life;

(2) Before powering on the IMU, check the power supply system to ensure that there is no short circuit between the electrical points of the power supply and between the enclosure and the electrical points;

(3) If there is any abnormality in this product, please consult the manufacturer, and it is forbidden to disassemble and repair it without authorization;

(4) The IMU is a precision instrument, so it should be handled with care during use and transportation;

(5) The correct connection of product input and output signal lines and power supply lines must be ensured;

(6) Anti-static measures are required to be taken during the contact with the product;

(7) The magnetic field strength around the product location is required to be less than 2 Gauss.

## Maintenance

(1) Before the product is loaded into the carrier, it is required to power on the product at least once every 6 months, and the power-on time is 3600s. The power-on time does not require testing the electrical parameters of the product;

(2) After the product is loaded into the carrier, it is required to be energized at least once a year, and the power-on time is 3600s, and the electrical parameters of the product are not required to be tested when the product is energized;

(3) The product should be re-calibrated every 8 years (by the production unit).

No.	Failure phenomenon	Cause Analysis	Method of exclusion
1	The product is energized, and the ammeter indication is basically zero	The product is not powered or the current is too small	Check the power supply and power supply circuit, restore the power supply of the product
2	The product is powered on, the ammeter indicates normal, but the computer acquisition program does not work	Abnormal test equipment acquisition system	Check the connection cable and the power supply of the equipment
		Software program conflict	Restart the computer

## Transport and storage

### 1. Precautions for transportation

- (1) Place the product in the direction shown in the packaging box;
- (2) Transportation by road, railway, air and water transportation is allowed;
- (3) Ensure that the packing box is fastened to the carrier and will not move during transportation.

### 2. Storage conditions, storage period and precautions

- (1) The products placed in the packaging box should be stored in an air-conditioned warehouse under standard atmospheric pressure, with an ambient temperature of  $25^{\circ}\text{C} \pm 10^{\circ}\text{C}$ , a relative humidity of 30% to 70%, and the surrounding magnetic field strength less than 2 Gauss. ;
- (2) The product storage period is 15 years.

## Unpacking matters

- (1) Check the appearance of the outer packaging for physical damage such as collisions;
- (2) Check whether the products and supporting accessories are complete, see the table below for details;
- (3) Electrostatic protection treatment should be carried out when taking out the product.

No.	Name	Quantity
1	BW-IMU910 Fiber Inertial Measurement	1
2	Packing box	1
3	Testing report	1
4	J30J-21TJL Connector	1
5	Certificate of conformity	1



## Executive standard

- National Standard for Static Calibration Specifications for Dual-Axis Inclination Sensors (Draft)
- GB/T 191 SJ 20873-2003 General Specification for Inclinometers and Levels

# **BW-IMU910 Series**

**High-precision Fiber optic gyroscope  
Inertial measurement unit**

## **Wuxi Bewis Sensing Technology LLC**

Add: Building 30, No.58 Xiuxi Road, Binhu District,  
Wuxi City, Jiangsu Province, China

Tel: +86 18921292620

Email: [sales@bwsensing.com](mailto:sales@bwsensing.com)

Web: [www.bwsensing.com](http://www.bwsensing.com)