



# VG500C

Ultra High Accuracy  
; ynamic @Zçeometer  
Technical Manual



## Introduction

The VG500C Ultra high accuracy dynamic inclinometer that measures the attitude parameters (roll and pitch) of the motion carrier. The attitude deviation is estimated by a 6-state Kalman filter with appropriate gain and is suitable for tilt measurement in motion or vibration.

The VG500C uses high-quality and reliable MEMS accelerometers and gyroscopes, and guarantees measurement accuracy through algorithms. At the same time, the seal design and strict process ensure that the product can accurately measure the roll angle and pitch angle of the carrier under harsh environment. Through various compensations such as nonlinear compensation, quadrature compensation, temperature compensation and drift compensation, the error caused by interference can be greatly eliminated, and the product precision level can be improved. The VG500C has a digital interface that can be easily integrated into the user's system.

## Features

- Dynamic accuracy: 0.1°
- Static accuracy: 0.01°
- Nonlinear orthogonal compensation
- Special offset tracking algorithm eliminates the drift
- RS232/RS485/TTL interface output optional
- Operating temperature: -40°C~+85°C
- High performance Kalman filter algorithm
- Size: L60\*W59\*H29(mm)

## Applications

- Underwater unmanned boat
- Fan tower sloshing monitoring
- Platform stability
- Large ships
- Photoelectric pod
- Unmanned driving
- Automatic artillery
- Unmanned aerial vehicle

## Specifications

### Electrical Specifications

Power supply	9-35VDC
Operating current	30mA (Max 40mA)
Operating temperature	-40°C~85°C
Store temperature	-55°C~100°C

### Performance Specifications

Attitude parameter	Dynamic accuracy	0.1°
	Static accuracy	0.01°
	Resolution	0.001°
	Tilt range	Pitch ± 90°, Roll ±180°
Physical characteristics	Size	L60× W59× H29 (mm)
	Weight (including cable)	280g
	Weight (including package)	360g
Interface characteristics	Start delay	<50ms
	Maximum output frequency	500Hz
	Serial communication rate	2400 to 115200 baud rate
	Digital output format	Binary high performance protocol
MTBF	≥90000 hours/time	
Electromagnetic compatibility	According to GBT17626	
Insulation resistance	≥100 MΩ	
Impact resistance	2000g, 0.5ms, 3 times / axis	

**Resolution:** The measured minimum change value that the sensor can detect and resolve within the measurement range.

**Accuracy:** The error between the actual angle and the Root mean square(RMS) of the measured angle of the sensor (≥16 times).

**Mechanical Characteristic**

Connector	Metal connector (standard cable is 1.5m)
Protection level	IP67
Shell material	Magnesium alloy anodizing
Installation	Four M4 screws

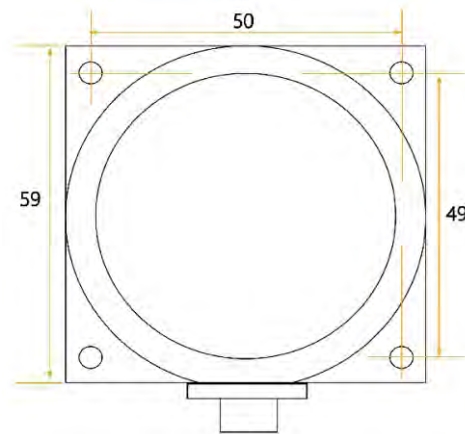
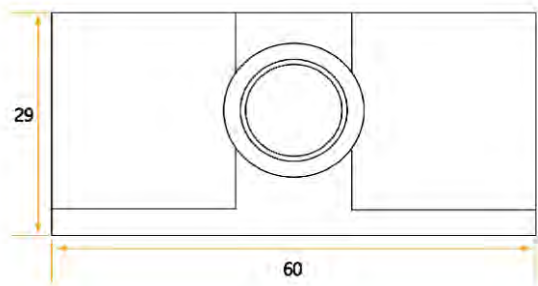

**Package size**

Product Size: L60× W59× H29mm

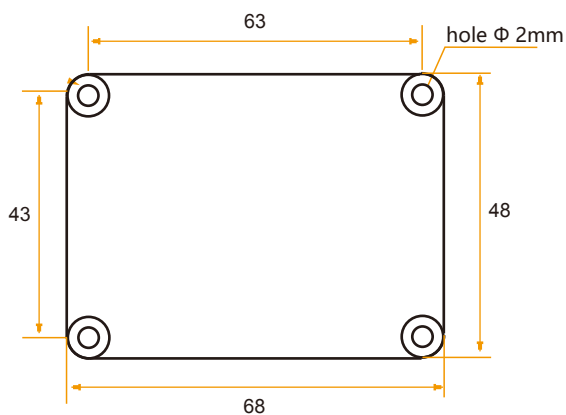

**PCB size**

PCB Size: L44\*W35\*H11mm, ±1mm error for length and width dimensions, please refer to actual size



## Installation direction

The correct installation method can avoid measurement error. The following points should be made when installing the sensor:

First of all, to ensure that the sensor mounting surface and the measured surface completely close, the measured surface should be as horizontal as possible, can not have the angle shown in Figure A and Figure C, the correct installation is shown in Figure B and Figure D.

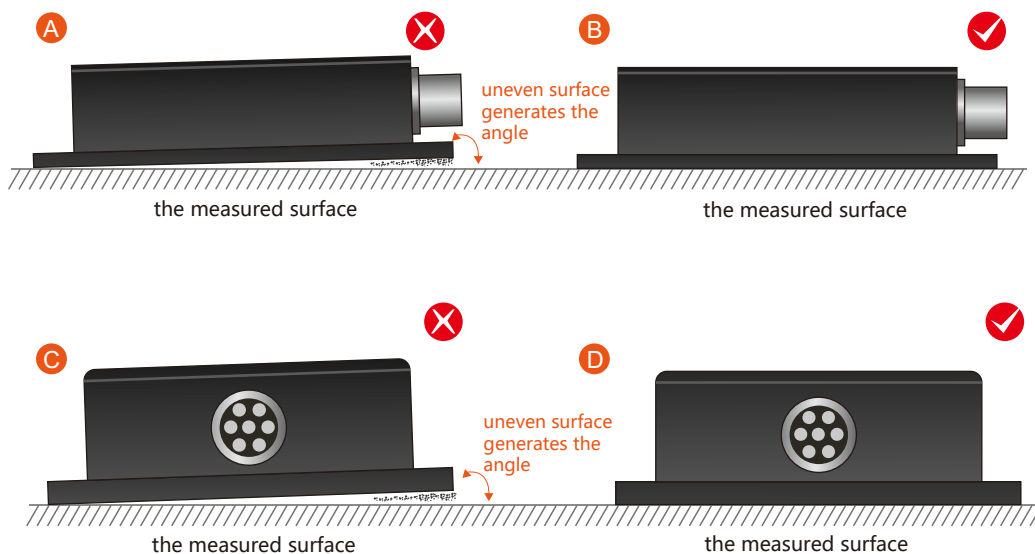

Secondly, the bottom cable of the sensor and the axis of the measured object shouldn't generate the angle shown in E. When installing, the bottom cable of the sensor should be kept parallel or orthogonal to the rotation axis of the measured object. This product can be installed horizontally or vertically (vertical installation requires customization). The correct installation method is shown in Figure F.

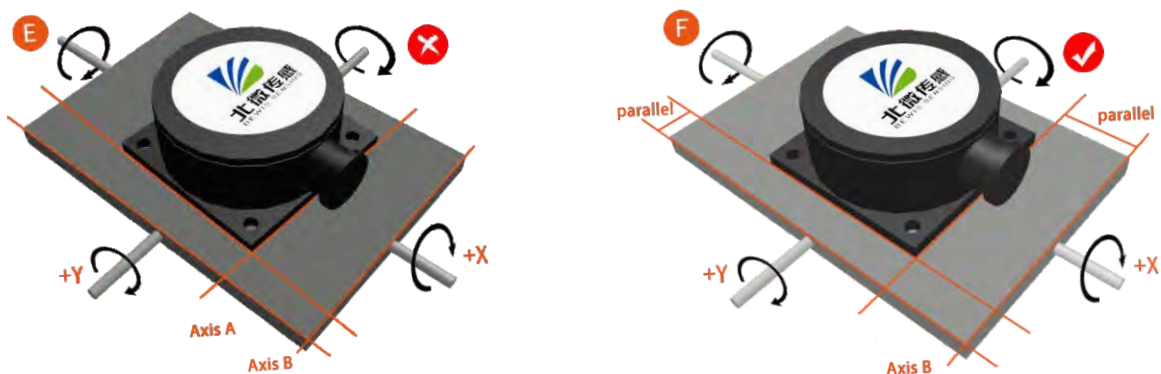

Finally, the installation surface of the sensor must be fixed with the measured surface tightly and smoothly, to avoid measurement error that may be caused by the acceleration and vibration.

## Electrical connections

### Electrical interfaces

Cable color & function	RED	BLUE	BLACK	GREEN	YELLOW
	1	2	3	4	5
	VCC DC 9-35V	NC	GND	RXD (B, D-)	TXD (A, D+)

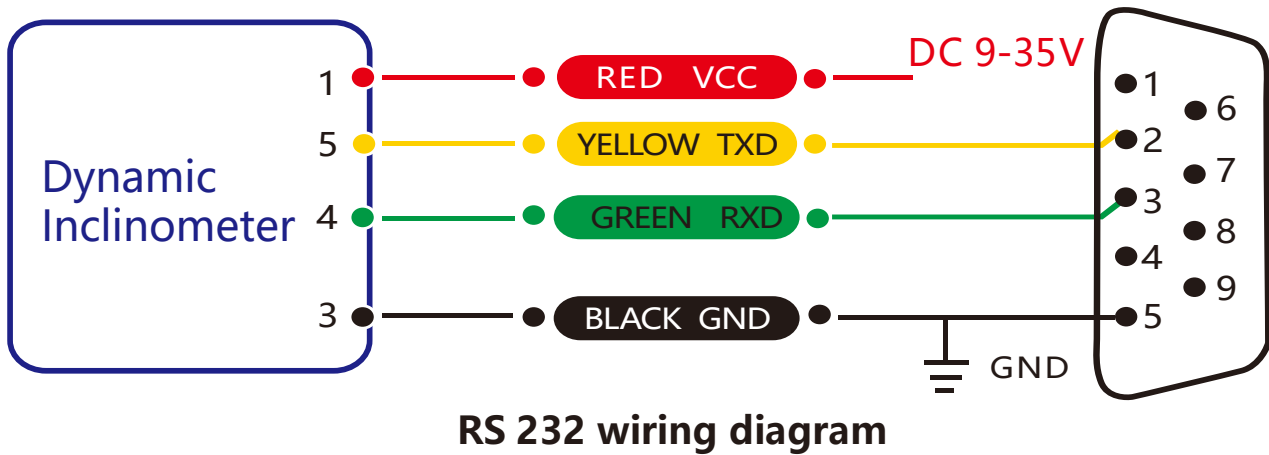
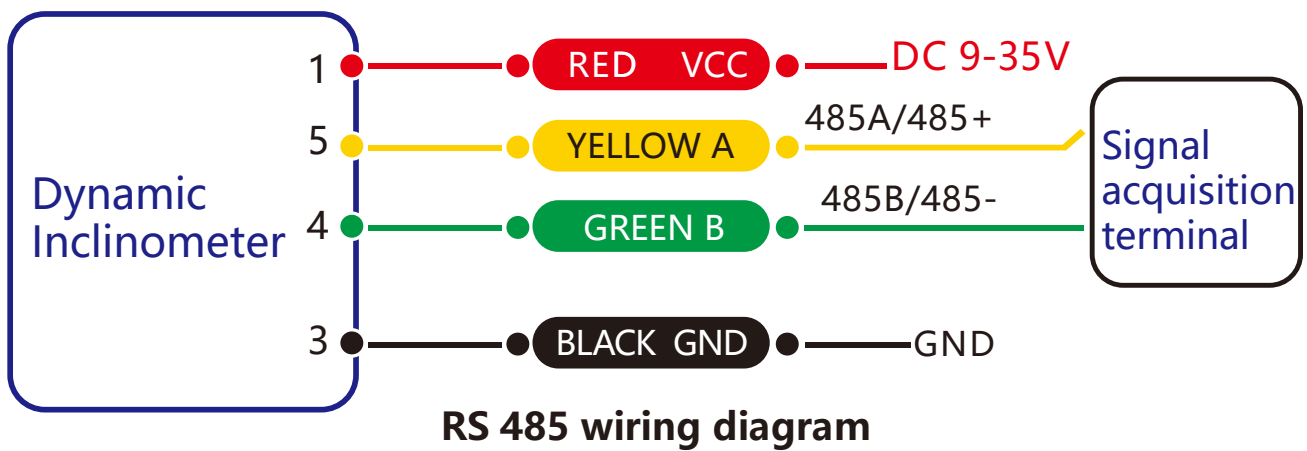

## Debug software

Users can directly download serial assistant on official website (Supports-Download). You can also use more convenient and intuitive PC software.

VG500C supporting serial debugging software can be connected to the inclinometer on the computer for angle display. The software debugging interface is as shown in the figure below. Using the debug software, it can conveniently display the current X-direction tilt angle, and you can also modify and set other parameters by yourself.

### Software use steps:

- ① Connect the serial port hardware of the inclinometer correctly and connect the power supply.
- ② Select the correct device model (select azimuth series).
- ③ Select the computer serial port and baud rate and click to connect to the serial port.
- ④ Click Start and the tilt angle of the inclinometer in the X and Y directions will be displayed on the screen.

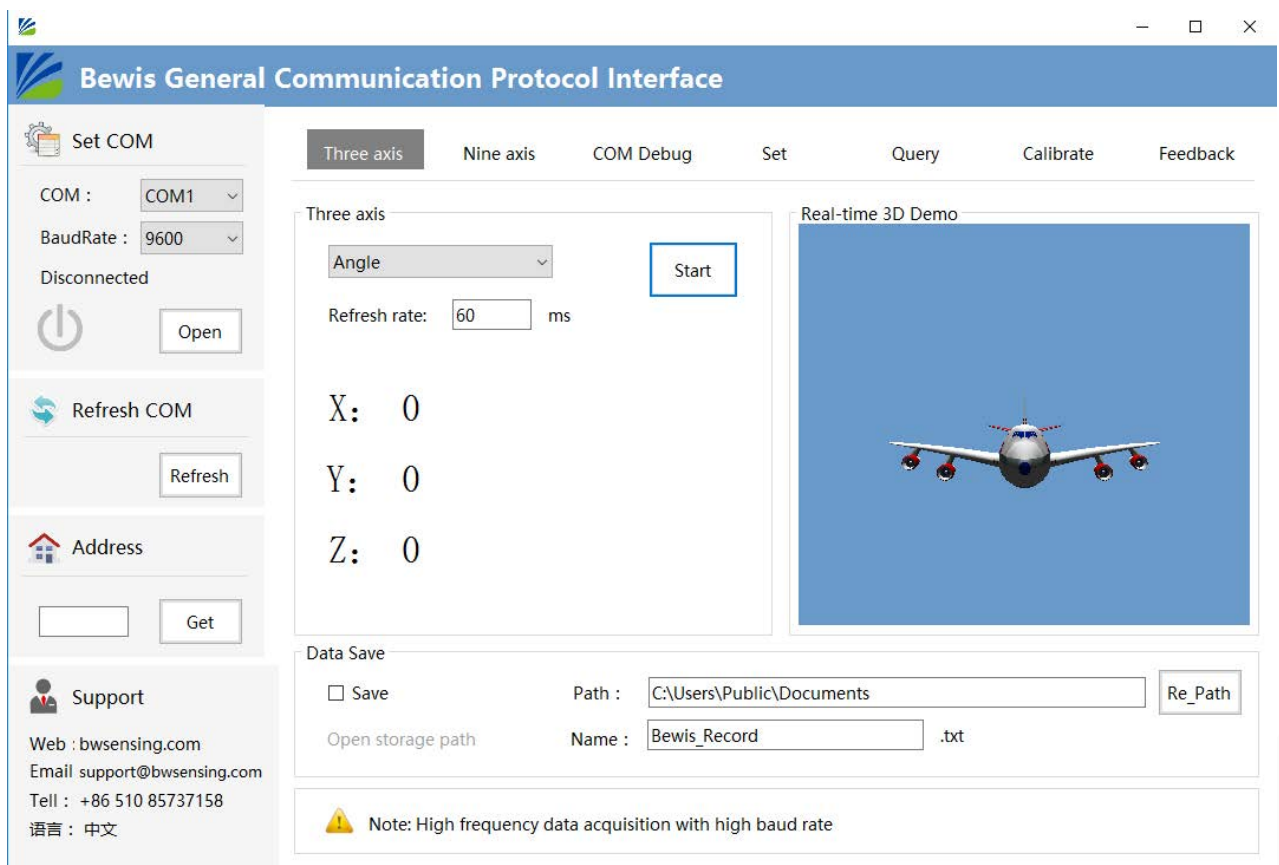

## Protocol

### 1. Data Frame Format: (8 data bits, 1 stop bit, No parity check, default baud rate 9600)

Identifier (1byte)	Frame Length (1byte)	Address Code (1byte)	Command (1byte)	Data (0byte)	Checksum (1byte)
0x77					

**Data Format:** Hexadecimal

**Identifier:** Fixed to 77

**Frame Length:** Length from Frame Length to Checksum (included)

**Address Code:** Address of acquiring module, default 0x00

**Data:** Content and length variable according to Command

**Checksum:** Sum of Frame Length, Address Code, Command and Data. (Please pay attention that when the command or data changes, the checksum will change.)

### 2. Command Format:

#### 2.1 Read PITCH angle Send command: 77 04 00 01 05

Identifier (1byte)	Frame Length (1byte)	Address Code (1byte)	Command (1byte)	Data (0byte)	Checksum (1byte)
0x77	0x04		0x01		0x05

#### Command response:

Identifier (1byte)	Frame Length (1byte)	Address Code (1byte)	Command (1byte)	Data (3byte)	Checksum (1byte)
0x77	0x07		0x81	SXXX.YY	

**Note:**The data field is a 3-byte return angle value, which is a compressed BCD code, S is a sign bit (0 positive, 1 negative) XXX is a three-digit integer value, and YY is a two-digit decimal value. The other axis data is the same. For example, 102770 means -27.70 degrees.

#### 2.2 Read ROLL angle Send command: 77 04 00 02 06

Identifier (1byte)	Frame Length (1byte)	Address Code (1byte)	Command (1byte)	Data (0byte)	Checksum (1byte)
0x77	0x04		0x02		0x06

#### Command response:

Identifier (1byte)	Frame Length (1byte)	Address Code (1byte)	Command (1byte)	Data (3byte)	Checksum (1byte)
0x77	0x07		0x82	SXXX.YY	

**Note:** The data field is the 3-byte return Angle value, is the compressed BCD code, S is the symbol bit (0 positive, 1 negative) XXX is the three-digit integer value, and YY is the two-digit fractional value. If the return value is 77 07 00 82 01 23 57 04, then the roll Angle data is 01 23 57, representing 123.57 degrees.



### 2.3 Read Heading azimuth angle    Send command: 77 04 00 04 08

Identifier (1byte)	Frame Length (1byte)	Address Code (1byte)	Command (1byte)	Data (0byte)	Checksum (1byte)
0x77	0x04		0x04		

#### Command response:

Identifier (1byte)	Frame Length (1byte)	Address Code (1byte)	Command (1byte)	Data (9byte)	Checksum (1byte)
0x77	0x0D		0x84	3 SXXX.YY	

**Pitch: +2.01°, Roll: -0.51°, YAW: 0.00°**

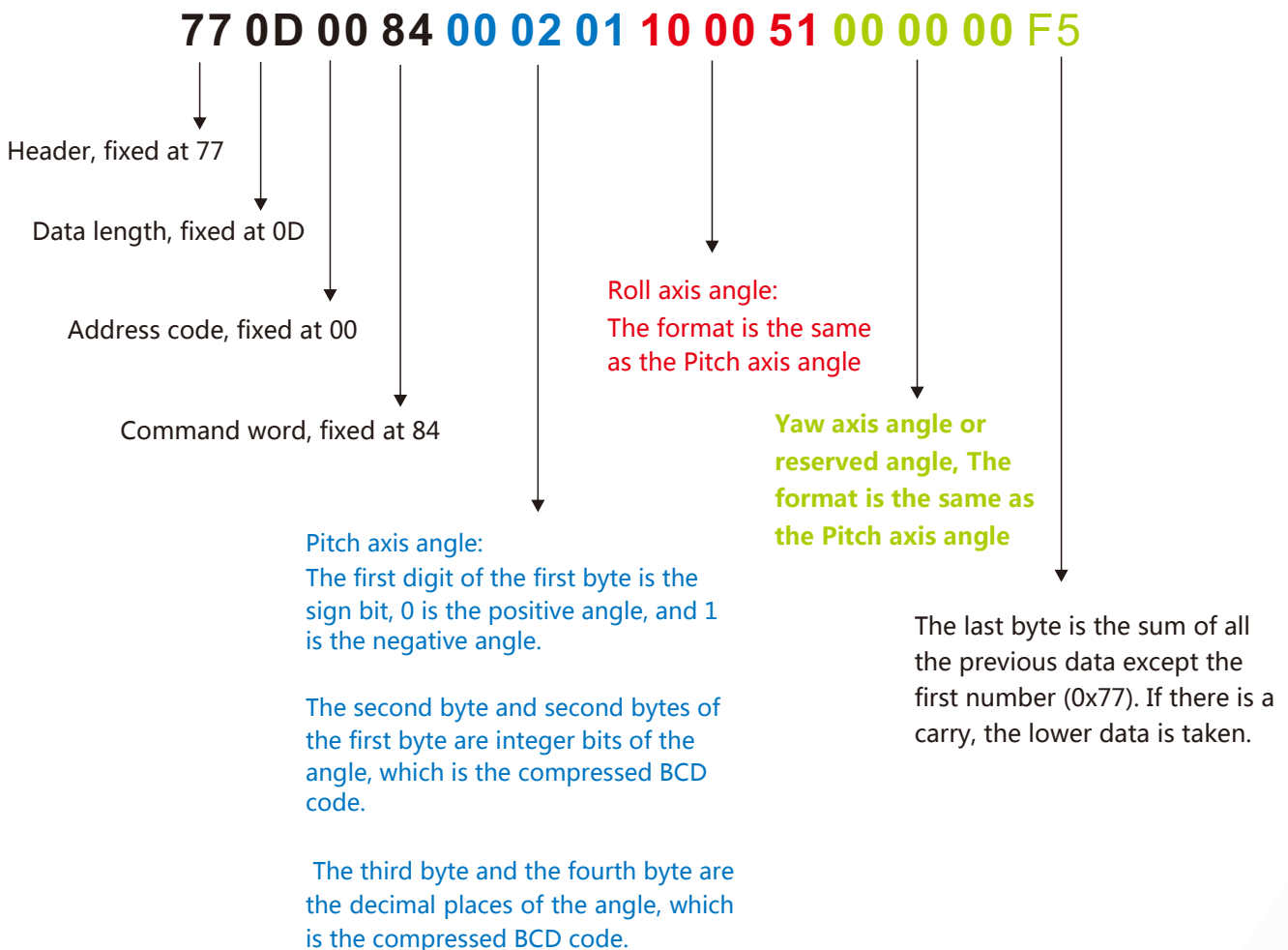

**2.4 Set baud rate**      Send command: 77 05 00 0B 02 12

Identifier (1byte)	Frame Length (1byte)	Address Code (1byte)	Command (1byte)	Data (1byte)	Checksum (1byte)
0x77	0x05		0x0B	XX	

**Command response:**

Identifier (1byte)	Frame Length (1byte)	Address Code (1byte)	Command (1byte)	Data (1byte)	Checksum (1byte)
0x77	0x05		0x8B	0x00: success 0xFF: failed	

**Note:** 0x00 is 2400, 0x01 is 4800, 0x02 is 9600, 0x03 is 19200, 0x04 is 115200, 0x05 is 38400, 0x06 is 57600, 0x07 is 460800. If the baud rate is set to 19200, The default setting value is 0x02: 9600 Each time the communication baud rate is changed successfully, the response command is sent back at the original baud rate, and then the device communication baud rate is immediately changed.

Note: If high frequency output is required, set the baud rate to 115200 or 460800, No need to save after modifying the baud rate, effective immediately.

**2.5 Set address**      Send command: 77 05 00 0F 01 15

Identifier (1byte)	Frame Length (1byte)	Address Code (1byte)	Command (1byte)	Data (1byte)	Checksum (1byte)
0x77	0x05	Current address	0x0F	New address	

**Command response:**

Identifier (1byte)	Frame Length (1byte)	Address Code (1byte)	Command (1byte)	Data (1byte)	Checksum (1byte)
0x77	0x05	New address	0x8F	0x00: success 0xFF: failed	

**Note:** For example, the following command "77 05 00 0F 0A 1E" means to change the address of the sensor from hexadecimal address 00 to 0A

**2.6 Query address**      Send command: 77 04 00 1F 23

Identifier (1byte)	Frame Length (1byte)	Address Code (1byte)	Command (1byte)	Data (0byte)	Checksum (1byte)
0x77	0x04	0x00	0x1F		0x23

**Command response:**

Identifier (1byte)	Frame Length (1byte)	Address Code (1byte)	Command (1byte)	Data (1byte)	Checksum (1byte)
0x77	0x05	Current address	0x1F	Current address	

**Note:** The query address command is fixed for this command.

### 2.7 Set the automatic output frequency Send command: 77 05 00 0C 00 11

Identifier (1byte)	Frame Length (1byte)	Address Code (1byte)	Command (1byte)	Data (0 byte)	Checksum (1byte)
0x77	0x05		0x0C	XX	

#### Command response:

Identifier (1byte)	Frame Length (1byte)	Address Code (1byte)	Command (1byte)	Data (1byte)	Checksum (1byte)
0x77	0x05		0x8C	0x00:success 0xFF: failure	

The data field XX sent is the automatic output frequency option: 00 indicates the answer mode

01 indicates 5Hz automatic output corresponding data type parameter

02 indicates 10Hz automatic output corresponding data type parameter

03 indicates 20Hz automatic output corresponding data type parameter

04 indicates 25Hz automatic output corresponding data type parameter

05 indicates 50Hz automatic output corresponding data type parameter

06 indicates 100Hz automatic output corresponding data type parameter

07 indicates 200Hz automatic output corresponding data type parameter

08 indicates 500Hz automatic output corresponding data type parameter

**Note:** When the automatic output frequency setting is high, the baud rate needs to be set to a high baud rate.

### 2.8 Query g value for acceleration

Send command: 77 04 00 54 58

Identifier (1byte)	Frame Length (1byte)	Address Code (1byte)	Command (1byte)	Data (0byte)	Checksum (1byte)
0x77	0x04		0x54		

#### Command response:

Identifier (1byte)	Frame Length (1byte)	Address Code (1byte)	Command (1byte)	Data (9byte)	Checksum (1byte)
0x77	0x0D		0x54	3 groups of SXXXYY	

**Note:** The data is the g value of pitch, roll and yaw, which is composed of 1 bit symbol bit +1 bit integer bit +4 bit decimal place.

If the return value is "77 0D 00 54 00 01 07 00 94 21 10 06 30 64", the values are 0.0107g, 0.9421g and -0.0630g, respectively

**2.9 Query angular velocity**

Send command: 77 04 00 54 54

Identifier (1byte)	Frame Length (1byte)	Address Code (1byte)	Command (1byte)	Data (0byte)	Checksum (1byte)
0x77	0x04		0x50		

Command response:

Identifier (1byte)	Frame Length (1byte)	Address Code (1byte)	Command (1byte)	Data (9byte)	Checksum (1byte)
0x77	0x0D		0x50	3groups of SXXXXY	

**Note:** The data domain is the magnitude of the angular velocity of pitch, roll and yaw, which is composed of 1 bit symbol +3 bit integer +2 bit decimal.

For example, if the return value is "77 0d 00 50 10 93 76 14 98 87 00 14 03 C0", then the data is as follows: angular velocity of pitch is -93.76°/s, angular velocity of roll is -498.87°/s, and angular velocity of yaw is +14.03°/s.

**2.10 Save setting** Send command: 77 04 00 0A 0E

Identifier (1byte)	Frame Length (1byte)	Address Code (1byte)	Command (1byte)	Data (0 byte)	Checksum (1byte)
0x77	0x04		0x0A		

Command response:

Identifier (1byte)	Frame Length (1byte)	Address Code (1byte)	Command (1byte)	Data (1byte)	Checksum (1byte)
0x77	0x05		0x8A	0x00: success 0xFF: failed	

Note: No need to save the baud rate, other settings need to be saved.

**2.11 Quaternion** Send command : 77 04 00 57 5B

Identifier (1byte )	Frame Length (1byte )	Address Code (1byte )	Command (1byte )	Data (0byte )	Checksum (1byte )
0x77	0x04		0x57		

Command response:

Identifier (1byte )	Frame Length (1byte)	Address Code (1byte )	Command (1byte )	Data (9byte )	Checksum (1byte )
0x77	0x14		0x57	4 groups of SXXXXYYY	

**Note:** The Data contains 16 bytes, one group with 4 bytes, which are quaternion q0, q1, q2, q3, which is a compressed BCD code, the format is SX YY YY YY,

S is the sign bit (0 is positive, 1 is negative), X is 1 integer bit, YYYYYY is 6 decimal places.

For example, if the command response: 77 14 00 57 00 99 99 96 00 00 02 90 10 00 26 73 10 00 00 01 7F, then the quaternary data are:

Where q0 is 00 99 99 96, which means 0.999996

q1 is 00 00 02 90, which means 0.000290

q2 is 10 00 26 73, which means -0.002673

q3 is 10 00 00 01, which means -0.000001

**2.12 Simultaneous reading angle, acceleration, angular velocity, quaternion**    Send command: 77 04 00 59 5D

Identifier (1byte)	Frame Length (1byte)	Address Code (1byte)	Command (1byte)	Data (0byte)	Checksum (1byte)
0x77	0x04		0x59		

Command response:

Identifier (1byte)	Frame Length (1byte)	Address Code (1byte)	Command (1byte)	Data (43bytes)	Checksum (1byte)
0x77	0x2F		0x59	Data	

Data contains 43 bytes, namely Angle, g value of gravity acceleration, angular velocity, quaternion, is compressed BCD code, four elements are the last 16 bytes, four bytes are a group, a total of four groups, the rest are 3 bytes are a group, the representation method is shown in the corresponding parameter return value. For example, the return value is as follows:

```
77 2F 00 59 10 00 60 10 03 06 00 00 00
    10 01 07 10 05 43 01 01 54
    10 00 13 10 00 04 00 00 09
    10 87 06 35 00 01 76 91 00 02 06 94 00 49 11 75 5C
```

Then: The three axis angles are -0.6, -3.06 and 0 degrees respectively;

The g values of the three axes were -0.0107g, -0.0543g and 1.0154g, respectively.

The angular velocities of the three axes are -0.13°/s, -0.04°/s and 0.09°/s respectively.

The four quaternions are -0.870635, 0.017691, 0.020694 and 0.491175, respectively.

**2.13 Automatic output data type selection**    Send command: 77 05 00 56 00 5B

Identifier (1byte )	Frame Length (1byte )	Address Code (1byte )	Command (1byte )	Data (0byte )	Checksum (1byte )
0x77	0x05		0x56	XX	

Command response:

Identifier (1byte )	Frame Length (1byte )	Address Code (1byte )	Command (1byte )	Data (16byte)	Checksum (1byte )
0x77	0x05		0x56	00	

**Note:** The data field XX is the corresponding output data type, which should be carried out in the automatic output mode:

0x00: When automatic output, the output parameter is triaxial Angle data, and the output format refers to command 2.3;

0x01: When automatic output, the output parameter is the three-axis acceleration value, and the output format refers to command 2.8;

0x02: When automatic output, the output parameter is the value of the three-axis gyroscope, and the output format is referred to command 2.9;

0x03: When automatic output, output parameter is triaxial Angle data (reserve other data types);

0x04: When automatic output, the output parameter is quaternion value, and the output format refers to command 2.11;

0x05: When automatic output, the output parameters are composed of Angle, acceleration, angular velocity and quaternion, and the output format refers to command 2.12.

## Ordering Information

Product number	Way of communication	Package condition
VG500C-232	RS232	IP67 Package / Metal connector
VG500C-485	RS485	IP67 Package / Metal connector
VG500C-TTL	TTL	IP67 Package / Metal connector

## Executive standard

- Enterprise Quality System Standard: ISO9001:2008 Standard (Certificate No.:10114Q16846ROS)
- CE certification (certificate number: 3854210814)
- ROHS (certificate number: SO81426003)
- GB/T 191 SJ 20873-2003 General specifications for tiltmeters and spirit levels
- GBT 18459-2001 sensor main static performance index calculation method
- JF 1059-1999 Evaluation and Expression of Measurement Uncertainty
- GBT 14412-2005 mechanical vibration and shock mechanical installation of accelerometer
- General requirements for GJB 450A-2004 equipment reliability
- Quality control of key parts and important parts of GJB 909A
- GJB 899 Reliability Qualification and Acceptance Test
- GJB 150-3A high temperature test
- GJB 150-4A low temperature test
- GJB 150-8A rain test
- GJB 150-12A dust test
- GJB 150-16A vibration test
- GJB 150-18A impact test
- GJB 150-23A Tilt and Swing Test
- GB/T 17626-3A RF electromagnetic radiation immunity test
- GB/T 17626-5A surge (hit) impulse immunity test
- GB/T 17626-8A power frequency magnetic field immunity test
- GB/T 17626-11A voltage dips, short interruptions and voltage changes immunity

# VG500C

## Ultra High Accuracy Dynamic Inclinometer

### Wuxi Bewis Sensing Technology LLC

Address: Building 30, No. 58 Xiuxi Road, Binhu District, Wuxi City, Jiangsu Province, China

Tel/Whatsapp: +86 17606 118 008

Email: [support@bwsensing.com](mailto:support@bwsensing.com)

Website: [www.bwsensing.com](http://www.bwsensing.com)