



WF-WK200 Series

**High speed transmission
wireless Inclinometer**

Technical Manual



Introduction

WF-WK200 high-speed wireless transmission inclination sensor is a compact and intelligent digital inclination sensor designed for structural health monitoring. Rechargeable lithium battery or disposable dry battery, rechargeable lithium battery can work continuously for 24 hours on a single charge (continuous measurement and data transmission), and can be charged quickly with an external special charger. It can meet the demand of high precision and high frequency monitoring. Using disposable dry battery to upload data once an hour can be used continuously for 3 years, which can meet the long-term monitoring needs of customers. With remote control and management function, connect wireless router to transfer data to the cloud.

In terms of network connection, the sensor has the function of automatic disconnection and reconnection, which effectively avoids problems caused by connection loss caused by network abnormalities and server maintenance. The sensitive mechanism adopts the latest technology, the inclination unit of micro-electromechanical production technology, small size, low power consumption, high consistency and stability, because it is a digital inclination sensor module, the linearity is easier to be corrected. The working temperature reaches the industrial level $-40^{\circ}\text{C} \sim +85^{\circ}\text{C}$.

Feature

- Resolution: 0.02°
- Dual axis inclination measurement, Range $\pm 90^{\circ}$
- Magnetic Switch
- Data can be transferred to the cloud
- Accuracy: 0.2°
- Power query
- Timed wake up
- Exercise wake

Application

- Dangerous housing monitoring
- Bridge tower inclination measurement
- Dam monitoring
- Slope disaster prevention
- Ancient building protection monitoring
- Tunnel monitoring
- Foundation pit inclinometer
- Tower tilt monitoring

Product Feature



Mechanical index

Connector	Aviation connector
Protection level	IP68(1 m water depth, 24 hours continuous test)
Shell material	ABS+30% glass fiber + magnesium aluminum alloy anodized base
Installation	Four M6 screws



Performance index

Measurement range (°)	Condition	±90	°
Measurement axis	Mutually perpendicular	X-Y	
Accuracy (°)		0.2	°
Resolution (°)		0.02	°
Zero temperature drift (°/°C)	-40 ~ 85°C	±0.02	°/°C
Cross axis error (°)	25°C	0.2	°
Output frequency		Up to 50	Hz
Mean No Failure Working hours MTBF	≥90000 h		
EMC	According to GBT17626		
Insulation resistance	≥100 MΩ		
Impact resistance	2000g, 0.5ms, 3 times/axis		
Dimension	L105.2*W85*H76 (mm) (Antenna not included)		
Weight	/		

Resolution: The smallest change value of the measured value that the sensor can detect and distinguish within the measurement range.

Accuracy: The root mean square error of the actual angle and the sensor measuring angle for multiple (≥16 times) measurements.



Electrical index

Power connector	Power voltage	4.2VDC
	Disposable dry cell voltage	3.6VDC
	Working current	50mA (Average value)
	Stand-by current	6μA(Typical values)
	Rechargeable battery capacity	6000mAH
	Disposable dry cell battery capacity	19000mAH
	Communication distance	Maximum: 5Km
Limited Data	Every frame 20Byte	
Reliability	The mean time between failures (MTBF) is not less than 50,000 hours Ultra-low power consumption design, including automatic sleep mode, timing wake-up, sports wake-up	



Network topology

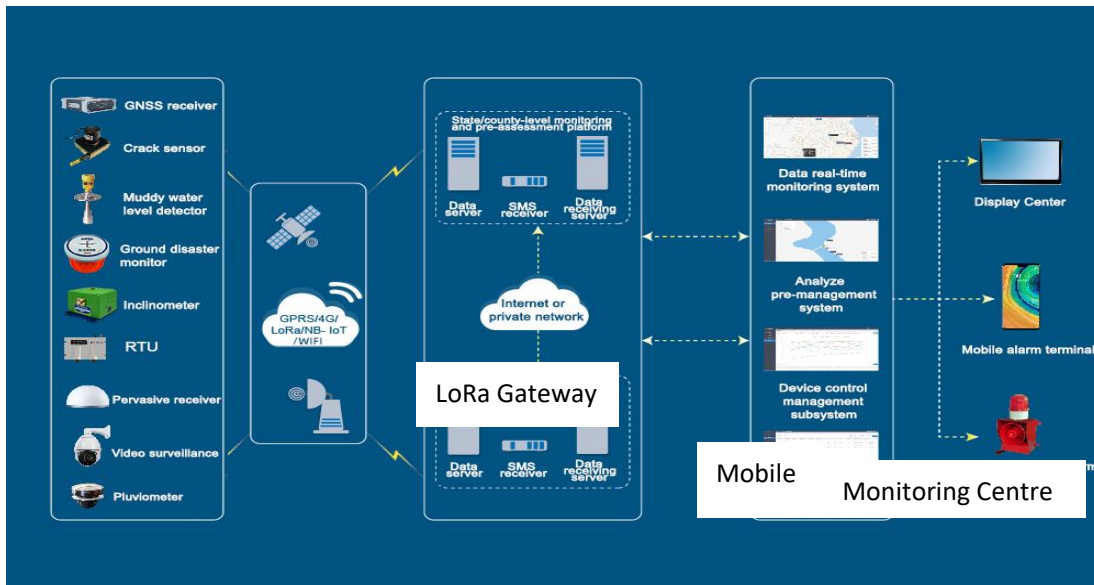



Package product size

Product size: (Antenna not included) L105.2*W85*H76 (mm) , the length and width may be a 1mm error, please refer to the actual product

Standard antenna height: 159mm (this product without antenna cap)

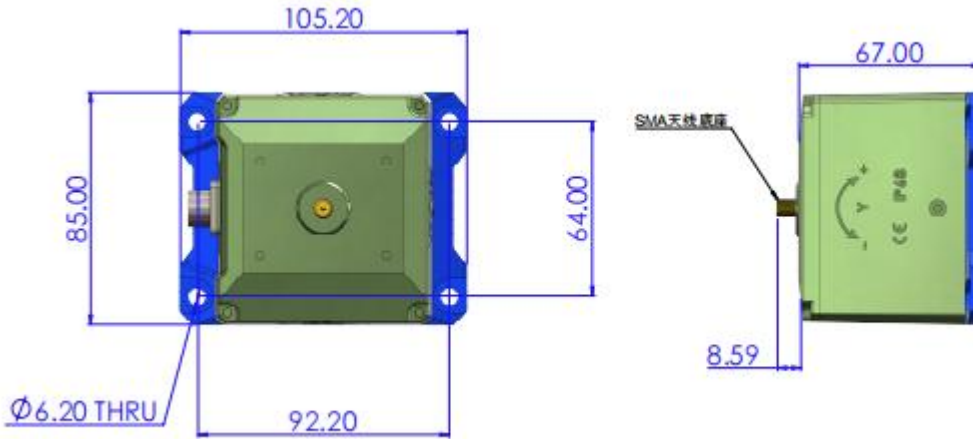

Electrical connections

Aviation plug wiring definition

	RED	BLACK	GREEN	YELLOW
Wiring color	1	3	4	5
function	4.2V	GND	RXD	TXD

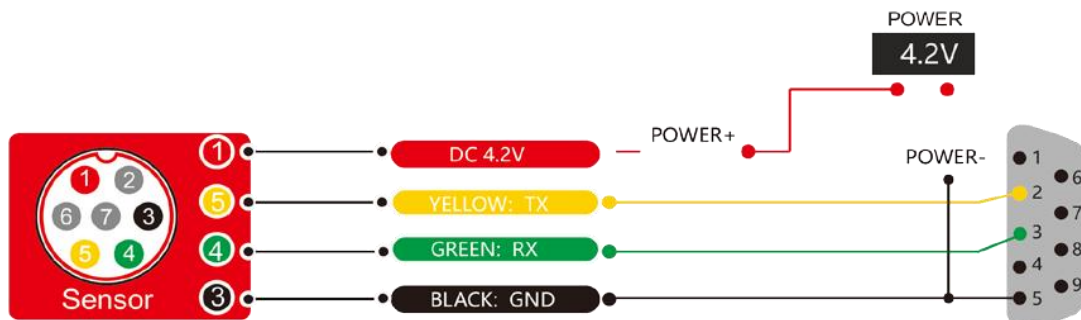

Installation

This series of products can only be installed vertically (pendulum type measurement), not horizontally. The correct installation method can avoid measurement errors. The following points should be done when installing the sensor:

First of all, make sure that the sensor mounting surface is completely close to the measured surface, and the measured surface should be as level as possible, and there should be no included angles as shown in Figure A and Figure C. The correct installation method is shown in Figure B and Figure D.

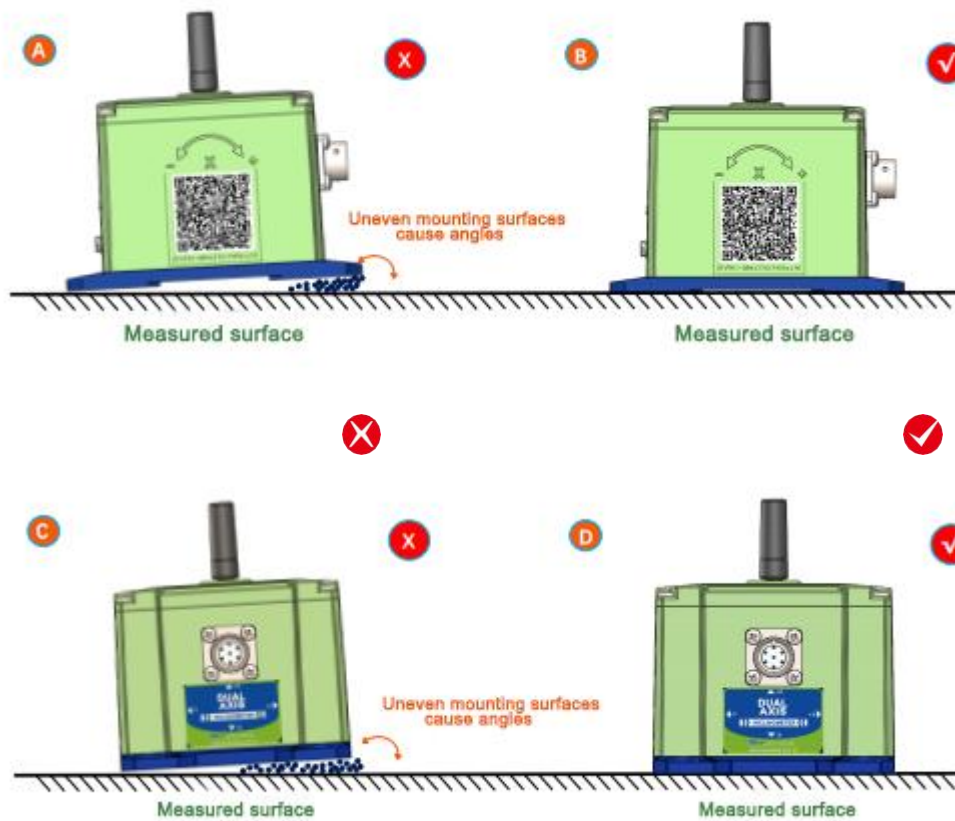

Secondly, the bottom line of the sensor and the axis of the measured object cannot have an angle as shown in Figure E, and the bottom line of the sensor should be kept parallel or orthogonal to the axis of rotation of the measured object during installation. This product can be installed horizontally or vertically (vertical installation needs to be customized), and the correct installation method is shown in Figure F.

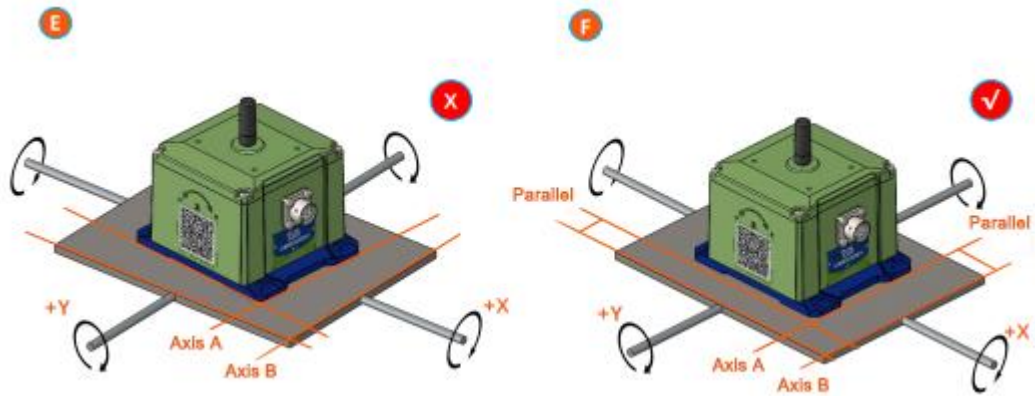

Finally, the mounting surface of the sensor and the surface to be measured must be tightly fixed, smooth in contact, and stable in rotation, and measurement errors due to acceleration and vibration must be avoided.

Executive standard

- Enterprise Quality System Standard: ISO9001:2015 Standard (Certificate No.064-21-Q-3290-RO-S)
- CE certification (certificate number: M.2019.103. U Y1151)
- ROHS (certificate Number: G 190930099)
- GB/T 191 SJ 20873-2003 General specification for inclinometer and level
- GBT 18459-2001 The calculation method of the main static performance index of the sensor
- JJF 1059.1-2012 Evaluation and expression of measurement uncertainty
- GBT 14412-2005 Mechanical vibration and shock Mechanical installation of accelerometer
- GJB 450A-2004 General requirements for equipment reliability
- GJB 909A Quality control of key parts and important parts
- GJB899 Reliability appraisal and acceptance test
- GJB150-3A High temperature test
- GJB150-4A Low temperature test
- GJB150-8A Rain test
- GJB150-12A Sand and dust experiment
- GJB150-16A Vibration test
- GJB150-18A Impact test
- GJB150-23A Tilt and rock test
- GB/T 17626-3A Radio frequency electromagnetic field radiation immunity test
- GB/T 17626-5A Surge (impact) immunity test
- GB/T 17626-8A Power frequency magnetic field immunity test
- GB/T 17626-11A Immunity to voltage dips, short-term interruptions and voltage changes

WF-WK200 Series

High speed transmission
Wireless inclinometer

Wuxi Bewis Sensing Technology LLC

Add: Building 30, NO. 58, Xiuxi Road, Binhu District,
Wuxi City, Jiangsu Province, China

Tel: +86 18921292620

Mail: sales@bwsensing.com

Web: www.bwsensing.com